

datasheet

PRELIMINARY SPECIFICATION

1/4" b&w CMOS 1 megapixel (1280 x 800) image sensor
with OmniPixel3-GS™ technology

OV9281

Copyright ©2015 OmniVision Technologies, Inc. All rights reserved.

This document is provided “as is” with no warranties whatsoever, including any warranty of merchantability, non-infringement, fitness for any particular purpose, or any warranty otherwise arising out of any proposal, specification, or sample.

OmniVision Technologies, Inc. and all its affiliates disclaim all liability, including liability for infringement of any proprietary rights, relating to the use of information in this document. No license, expressed or implied, by estoppel or otherwise, to any intellectual property rights is granted herein.

The information contained in this document is considered proprietary to OmniVision Technologies, Inc. and all its affiliates. This information may be distributed to individuals or organizations authorized by OmniVision Technologies, Inc. to receive said information. Individuals and/or organizations are not allowed to re-distribute said information.

Trademark Information

OmniVision and the OmniVision logo are registered trademarks of OmniVision Technologies, Inc. OmniPixel3-GS is a trademark of OmniVision Technologies, Inc.

All other trademarks used herein are the property of their respective owners.

b&w CMOS 1 megapixel (1280 x 800) image sensor with OmniPixel3-GS™ technology

datasheet (CSP5)
PRELIMINARY SPECIFICATION

version 1.01
september 2015

To learn more about OmniVision Technologies, visit www.ovt.com.

OmniVision Technologies is publicly traded on NASDAQ under the symbol OVTI.

applications

- industrial bar code scanning

ordering information

- **OV09281-H64A** (b&w, lead-free)
64-pin CSP5

features

- 3 μm x 3 μm pixel with OmniPixel3-GS™ technology
- automatic black level calibration (ABLC)
- programmable controls for frame rate, mirror and flip, cropping and windowing
- support output formats: 8/10-bit RAW
- fast mode switching
- supports 2x2 monochrome binning
- two-lane MIPI serial output interface
- supports horizontal and vertical 2:1 and 4:1 monochrome subsampling
- support for image sizes: 1280x800, 1280x720, 640x480, 640x400
- embedded 256 bits of one-time programmable (OTP) memory for part identification
- two on-chip phase lock loops (PLLs)
- LED PWM
- built-in strobe control

key specifications (typical)

- **active array size:** 1296 x 816
- **power supply:**
analog: 2.8V (nominal)
core: 1.2V (nominal)
I/O: 1.8V (nominal)
- **power requirements:**
active: TBD
standby: TBD
XSHUTDOWN: TBD
- **temperature range:**
operating: -30°C to +85°C junction temperature
stable image: 0°C to 50°C junction temperature
- **output interface:** 2-lane MIPI serial output
- **output formats:** 10-bit RAW
- **lens size:** 1/4"
- **input clock frequency:** 6~27 MHz
- **lens chief ray angle:** 9° non-linear
- **max S/N ratio:** TBD
- **dynamic range:** TBD
- **maximum image transfer rate:**
1280 x 800: 120 fps (see [table 2-1](#))
- **sensitivity:** TBD
- **scan mode:** progressive
- **maximum exposure interval:** TBD
- **pixel size:** 3 μm x 3 μm
- **dark current:** TBD
- **image area:** 3896 μm x 2453 μm
- **package dimensions:** 5232 μm x 4458 μm



note

Maximum integration time of dark current depends on read out speed (e.g., for 100fps, max dark current is around $3.5e^{-}$ at 50°C).

Confidential for
honeywell-suzhou

table of contents

1 signal descriptions	1-1
2 system level description	2-1
2.1 overview	2-1
2.2 architecture	2-1
2.3 format and frame	2-3
2.3.1 MIPI interface	2-4
2.3.2 VSYNC timing in MIPI mode	2-5
2.4 I/O control	2-6
2.5 power management	2-7
2.5.1 power up sequence	2-7
2.5.2 power down sequence	2-9
2.6 reset	2-12
2.6.1 power ON reset generation	2-12
2.7 hardware and software standby	2-12
2.8 system clock control	2-13
2.8.1 PLL configuration	2-13
2.9 serial camera control bus (SCCB) interface	2-17
2.9.1 data transfer protocol	2-17
2.9.2 message format	2-17
2.9.3 read / write operation	2-18
2.9.4 SCCB timing	2-21
2.9.5 group write and fast mode switching	2-22
3 block level description	3-1
3.1 pixel array structure	3-1
3.2 subsampling	3-2
4 image sensor core digital functions	4-1
4.1 mirror and flip	4-1
4.2 image windowing	4-2
4.3 test pattern	4-3
4.3.1 general test pattern bar	4-3
4.3.2 solid color test pattern	4-3
4.4 black level calibration (BLC)	4-4

4.5	one time programmable (OTP) memory	4-7
4.5.1	OTP memory structure	4-7
4.5.2	accessing the OTP memory	4-7
4.5.3	procedure for accessing OTP memory	4-9
4.5.4	procedure to read OTP content	4-9
4.5.5	procedure to program OTP content	4-9
4.5.6	power supply requirement for OTP memory programming	4-10
4.6	LED PWM	4-10
4.7	strobe	4-11
4.8	low power modes	4-12
4.8.1	low frame rate mode	4-13
4.8.2	snapshot mode	4-13
4.8.3	external trigger snapshot mode	4-14
5	image sensor processor digital functions	5-1
5.1	ISP general controls	5-1
5.2	manual white balance (MWB)	5-1
5.3	manual exposure and gain control	5-2
6	system control	6-1
6.1	mobile industry processor interface (MIPI)	6-1
6.2	digital video port (DVP)	6-8
7	register tables	7-1
7.1	system control [0x0100 - 0x010A, 0x3000 - 0x301F - 0x303F]	7-1
7.2	PLL control [0x0300 - 0x0319]	7-8
7.3	SCCB and group hold control [0x3100 - 0x3107, 0x31FF - 0x320F]	7-10
7.4	manual AWB_gain control [0x3400 - 0x3406]	7-12
7.5	manual AEC/AGC [0x3500 - 0x351D]	7-12
7.6	analog control [0x3600 - 0x3684]	7-15
7.7	sensor control [0x3700 - 0x37AF]	7-16
7.8	timing control [0x3800 - 0x3835, 0x3837]	7-16
7.9	PWM and strobe control [0x3900 - 0x3904, 0x3910 - 0x391D, 0x3920 - 0x3933]	7-19
7.10	low power mode control [0x4F00 - 0x4F0D, 0x4F10 - 0x4F14]	7-21
7.11	BIST [0x3E00 - 0x3E12]	7-22
7.12	OTP control [0x3D80 - 0x3D87]	7-24
7.13	BLC control [0x4000 - 0x4017, 0x4020 - 0x403F, 0x4042 - 0x4049]	7-25
7.14	frame control [0x4240 - 0x4244]	7-28

7.15	format control [0x4300 - 0x4307, 0x4311 - 0x4317, 0x4320, 0x4322 - 0x4329]	7-29
7.16	VFIFO control [0x4600 - 0x4602]	7-31
7.17	DVP control [0x4701 - 0x4709, 0x470C, 0x470F]	7-31
7.18	MIPI top [0x4800 - 0x4808, 0x4810 - 0x483D, 0x484A- 0x484F]	7-33
7.19	ISP top [0x5000 - 0x5018, 0x5020 - 0x5024, 0x5030 - 0x5035, 0x5E00 - 0x5E2E]	7-40
7.20	window control [0x5A00 - 0x5A09, 0x5A10 - 0x5A2F]	7-45
8	operating specifications	8-1
8.1	absolute maximum ratings	8-1
8.2	functional temperature	8-1
8.3	DC characteristics	8-2
8.4	timing characteristics	8-3
9	mechanical specifications	9-1
9.1	physical specifications	9-1
9.2	IR reflow specifications	9-2
10	optical specifications	10-1
10.1	sensor array center	10-1
10.2	lens chief ray angle (CRA)	10-2
10.3	IR cut off wavelength	10-3

OV9281

b&w CMOS 1 megapixel (1280 x 800) image sensor with OmniPixel3-GS™ technology

Confidential for
honeywell-suzhou

list of figures

figure 1-1	pin diagram	1-5
figure 2-1	OV9281 block diagram	2-2
figure 2-2	reference design schematic	2-3
figure 2-3	MIPI timing	2-4
figure 2-4	VSYNC timing in mode 1	2-5
figure 2-5	VSYNC timing in mode 2	2-5
figure 2-6	VSYNC timing in mode 3	2-5
figure 2-7	power up sequence	2-8
figure 2-8	power down sequence	2-10
figure 2-9	standby sequence	2-11
figure 2-10	PLL1 clock diagram	2-13
figure 2-11	PLL2 clock diagram	2-13
figure 2-12	clock connection diagram	2-16
figure 2-13	message type	2-17
figure 2-14	SCCB single read from random location	2-18
figure 2-15	SCCB single read from current location	2-18
figure 2-16	SCCB sequential read from random location	2-19
figure 2-17	SCCB sequential read from current location	2-19
figure 2-18	SCCB single write to random location	2-20
figure 2-19	SCCB sequential write to random location	2-20
figure 2-20	SCCB interface timing	2-21
figure 3-1	sensor array region color filter layout	3-1
figure 3-2	example of 2x2 binning	3-2
figure 3-3	example of 2:1 skipping	3-2
figure 3-4	example of 4:1 skipping	3-2
figure 4-1	mirror and flip samples	4-1
figure 4-2	image windowing	4-2
figure 4-3	test pattern	4-3
figure 4-4	OTP access	4-9
figure 4-5	LED PWM output timing	4-10
figure 4-6	low frame rate mode timing	4-13
figure 4-7	snapshot mode timing	4-13

figure 4-8	external snapshot mode timing	4-14
figure 4-9	frame triggered by red pulse diagram	4-14
figure 9-1	package specifications	9-1
figure 9-2	IR reflow ramp rate requirements	9-2
figure 10-1	sensor array center	10-1
figure 10-2	chief ray angle (CRA)	10-2

Confidential for
honeywell-suzhou

list of tables

table 1-1	signal descriptions	1-1
table 1-2	configuration under various conditions	1-3
table 1-3	pad symbol and equivalent circuit	1-5
table 2-1	supported resolution and frame rate	2-3
table 2-2	MIPI timing specifications (2-lane mode)	2-4
table 2-3	I/O control registers	2-6
table 2-4	power up sequence	2-7
table 2-5	power up sequence timing constraints	2-7
table 2-6	power down sequence	2-9
table 2-7	power down sequence timing constraints	2-9
table 2-8	hardware and software standby description	2-12
table 2-9	PLL control registers	2-14
table 2-10	sample PLL configuration	2-15
table 2-11	PLL speed limitation	2-16
table 2-12	SCCB interface timing specifications	2-21
table 2-13	context switching control	2-22
table 3-1	binning-related registers	3-2
table 4-1	mirror and flip registers	4-1
table 4-2	image windowing control functions	4-2
table 4-3	general test pattern bar selection control	4-3
table 4-4	solid color test pattern control	4-3
table 4-5	BLC control functions	4-4
table 4-6	ALS algorithm control registers	4-5
table 4-7	OTP memory structure	4-7
table 4-8	LED PWM registers	4-11
table 4-9	non-volatile memory map table (OTP)	4-11
table 4-10	strobe control registers	4-11
table 4-11	low power mode control registers	4-12
table 5-1	ISP top registers	5-1
table 5-2	manual AWB_gain registers	5-1
table 5-3	manual exposure and gain control registers	5-2
table 6-1	MIPI top control registers	6-1

table 6-2	DVP control registers	6-8
table 7-1	system control registers	7-1
table 7-2	PLL control registers	7-8
table 7-3	SCCB and group hold registers	7-10
table 7-4	manual AWB_gain registers	7-12
table 7-5	manual AEC/AGC registers	7-12
table 7-6	analog control registers	7-15
table 7-7	sensor control registers	7-16
table 7-8	timing control registers	7-16
table 7-9	PWM and strobe control registers	7-19
table 7-10	low power mode control registers	7-21
table 7-11	BIST control registers	7-22
table 7-12	OTP control registers	7-24
table 7-13	BLC control registers	7-25
table 7-14	frame control registers	7-28
table 7-15	format control registers	7-29
table 7-16	VFIFO control registers	7-31
table 7-17	DVP control registers	7-31
table 7-18	MIPI top control registers	7-33
table 7-19	ISP top registers	7-40
table 7-20	window control registers	7-45
table 8-1	absolute maximum ratings	8-1
table 8-2	functional temperature	8-1
table 8-3	DC characteristics (TA = 23°C ± 2°C)	8-2
table 8-4	timing characteristics	8-3
table 9-1	package dimensions	9-1
table 9-2	reflow conditions	9-2
table 10-1	CRA versus image height plot	10-2

1 signal descriptions

table 1-1 lists the signal descriptions and their corresponding pin numbers for the OV9281 image sensor. The package information is shown in **section 9**.

table 1-1 signal descriptions (sheet 1 of 3)

pin number	signal name	pin type	description
A1	NC	–	no connect
A2	DVDD	power	power for digital circuit
A3	DOGND	ground	ground for I/O
A4	SDA	I/O	SCCB data
A5	XSHUTDOWN	input	reset and power down (active low with internal pull down resistor)
A6	ILPWM	I/O	mechanical shutter output indicator
A7	DOGND	ground	ground for I/O
A8	NC	–	no connect
B1	DVDD	power	power for digital circuit
B2	DOGND	ground	ground for I/O
B3	DVDD	power	power for digital circuit
B4	D8	I/O	DVP output data[8]
B5	FSIN/VSYNC	I/O	frame sync input / vertical sync output
B6	STROBE	I/O	frame exposure output indicator
B7	DOVDD	power	power for I/O circuit
B8	AVDD	power	power for analog circuit
C1	AVDD	power	power for analog circuit
C2	PCLK	I/O	DVP output clock
C3	D1/GPIO1/ROI1	I/O	DVP output data[1] / general purpose I/O / ROI1
C4	D9	I/O	DVP output data[9]
C5	DVDD	power	power for digital circuit
C6	ULPM	I/O	ALS trigger indicator
C7	ATEST	analog	analog test
C8	AGND	ground	ground for analog circuit
D1	HREF	I/O	DVP output horizontal reference

table 1-1 signal descriptions (sheet 2 of 3)

pin number	signal name	pin type	description
D2	AGND	ground	ground for analog circuit
D3	DOVDD	power	power for I/O circuit
D4	D0/GPIO0/ROI0	I/O	DVP output data[0] / general purpose I/O / ROI0
D5	PVDD	power	PLL analog power
D6	GPIO2/CONTEXT	I/O	general purpose I/O / context switch select
D7	VN1	input	reference
D8	DVDD	power	power for digital circuit
E1	SID	input	SCCB ID select input
E2	XVCLK	input	system input clock
E3	EGND	ground	MIPI/PLL digital ground
E4	SCL	input	SCCB input clock
E5	EGND	ground	MIPI/PLL digital ground
E6	TM	input	test mode (active high with internal pull down resistor)
E7	VN2	input	reference
E8	VH	input	reference
F1	DOGND	ground	ground for I/O
F2	DVDD	power	power for digital circuit
F3	EVDD	power	MIPI/PLL digital power
F4	DOGND	ground	ground for I/O
F5	MDN1/D7	I/O	MIPI negative data[1] / DVP output data[7]
F6	DOGND	ground	ground for I/O
F7	VN3	input	reference
F8	AGND	ground	ground for analog circuit
G1	DVDD	power	power for digital circuit
G2	DOGND	ground	ground for I/O
G3	MDP0/D2	I/O	MIPI positive data[0] / DVP output data[2]
G4	MCP/D4	I/O	MIPI positive clock / DVP output data[4]
G5	MDP1/D6	I/O	MIPI positive data[1] / DVP output data[6]
G6	DVDD	power	power for digital circuit
G7	AVDD	power	power for analog circuit

table 1-1 signal descriptions (sheet 3 of 3)

pin number	signal name	pin type	description
G8	AVDD	power	power for analog circuit
H1	NC	–	no connect
H2	DOVDD	power	power for I/O circuit
H3	MDN0/D3	I/O	MIPI negative data[0] / DVP output data[3]
H4	MCN/D5	I/O	MIPI negative clock / DVP output data[5]
H5	EVDD	power	MIPI/PLL digital power
H6	DOVDD	power	power for I/O circuit
H7	AGND	ground	ground for analog circuit
H8	NC	–	no connect

table 1-2 configuration under various conditions (sheet 1 of 2)

pin number	signal name	XSHUTDOWN ^a	after XSHUTDOWN release ^b	software standby ^c
A4	SDA	high-z	input/open drain	input/open drain
A5	XSHUTDOWN	input	input	input
A6	ILPWM	high-z	high-z by default	high-z by default (configurable)
B4	D8	high-z	high-z by default	high-z by default (configurable)
B5	FSIN/VSYNC	high-z	high-z by default	high-z by default (configurable)
B6	STROBE	high-z	high-z by default	high-z by default (configurable)
C2	PCLK	high-z	high-z by default	high-z by default (configurable)
C3	D1/GPIO1/ROI1	high-z	high-z by default	high-z by default (configurable)
C4	D9	high-z	high-z by default	high-z by default (configurable)
C6	ULPM	high-z	input/open drain	input/open drain
D1	HREF	high-z	high-z by default	high-z by default (configurable)

table 1-2 configuration under various conditions (sheet 2 of 2)

pin number	signal name	XSHUTDOWN ^a	after XSHUTDOWN release ^b	software standby ^c
D4	D0/GPIO0/ROI0	high-z	high-z by default	high-z by default (configurable)
D6	GPIO2/CONTEXT	high-z	high-z by default	high-z by default (configurable)
E2	XVCLK	input	input	input
E4	SCL	input	input	input
E6	TM	input	input	input
F5	MDN1/D7	high-z	high-z by default	high-z by default (configurable)
G3	MDP0/D2	high-z	high-z by default	high-z by default (configurable)
G4	MCP/D4	high-z	high-z by default	high-z by default (configurable)
G5	MDP1/D6	high-z	high-z by default	high-z by default (configurable)
H3	MDN0/D3	high-z	high-z by default	high-z by default (configurable)
H4	MCN/D5	high-z	high-z by default	high-z by default (configurable)

- a. XSHUTDOWN = 0
b. XSHUTDOWN = 1
c. XSHUTDOWN = 1
standby initiated by register

figure 1-1 pin diagram

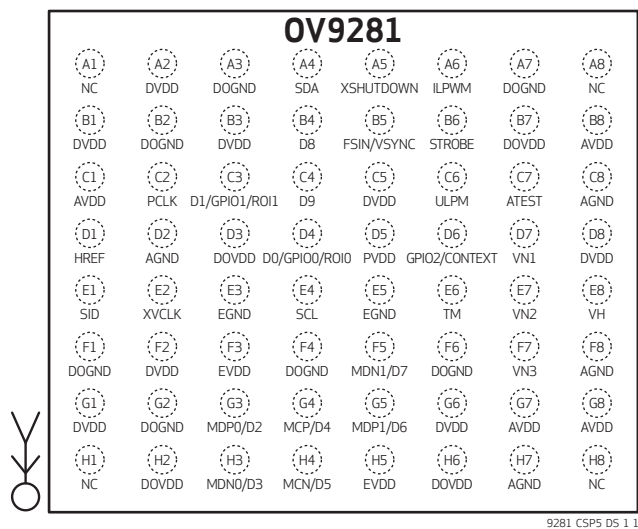

table 1-3 pad symbol and equivalent circuit (sheet 1 of 2)

symbol	equivalent circuit
XVCLK	
SDA, ULPM	
SCL	
FSIN/VSYNC, STROBE, ILPWM, D[9:0], GPIO[2:0], PCLK, HREF	

table 1-3 pad symbol and equivalent circuit (sheet 2 of 2)

symbol	equivalent circuit
VN1, VN2, VN3	
MDP0, MDN0, MDP1, MDP1, MCP, MCN, EGND, AGND, DGND, VH	
AVDD, EVDD, DVDD, DOVDD, PVDD	
TM, XSHUTDOWN, SID	

2 system level description

2.1 overview

The OV9281 image sensor is a low voltage, high performance 1/4-inch 1 megapixel b&w CMOS image sensor that provides the functionality of a single 1 megapixel (1280x800) camera using OmniPixel3-GS™ technology. The OV9281 provides full-frame, sub-sampled, and windowed 8/10-bit MIPI images via the control of the Serial Camera Control Bus (SCCB) interface.

The OV9281 has an image array capable of operating at up to 120 frames per second (fps) in 10-bit 1 megapixel resolution with complete user control over image quality, formatting and output data transfer.

In addition, OmniVision image sensors use proprietary sensor technology to improve image quality by reducing or eliminating common lighting/electrical sources of image contamination, such as fixed pattern noise, smearing, etc., to produce a clean, fully stable image.

For customized information purposes, the OV9281 includes 256 bits of one-time programmable (OTP) memory. The OV9281 has a one/two-lane MIPI interface.

2.2 architecture

The OV9281 sensor core generates streaming pixel data at a constant frame rate. **figure 2-1** shows the functional block diagram.

The timing generator outputs signals to access the image array. The entire pixel array is reset at the same point of time. After the exposure time has elapsed, the pixels stop gathering light and store the collected charge in a storage node. The charge then reads out row by row.

The exposure time is controlled by adjusting the time interval between reset and transferring the charge to storage node. After the data of the pixels in the row has been sampled, it is processed through analog circuitry to correct the offset and multiply the data with corresponding gain. Following analog processing is the ADC which outputs 10-bit data for each pixel in the array.

figure 2-1 OV9281 block diagram

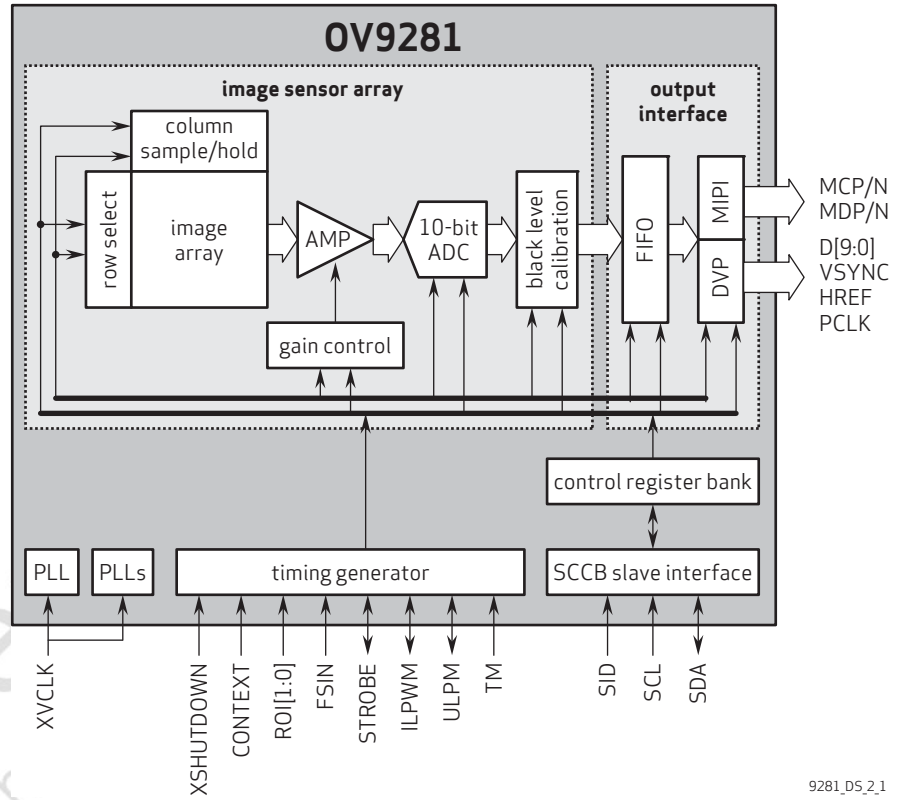

9281_D5_2_1

figure 2-2 reference design schematic

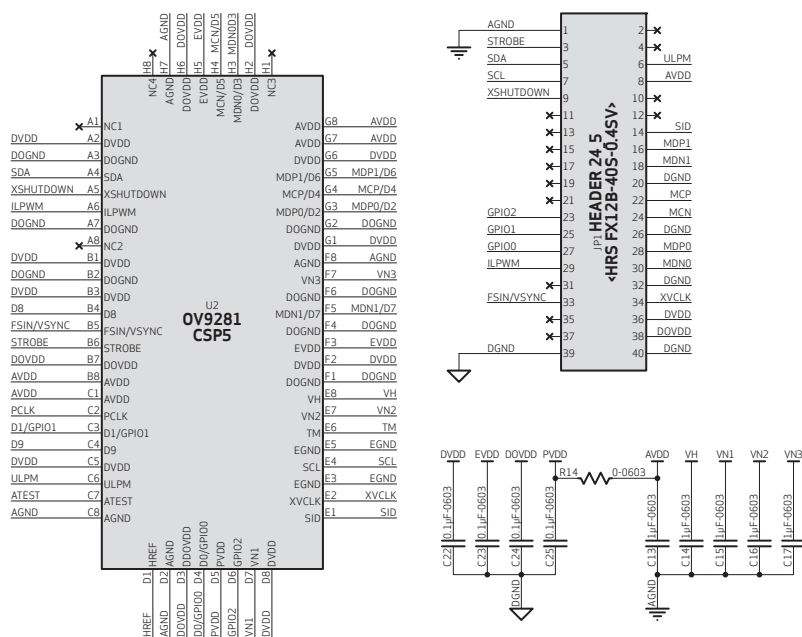

- note 1** XSHUTDOWN is active low and should be connected to DOVDD outside of module if unused.
- note 2** AVDD and PVDD is 2.7 - 3.0V of sensor analog power (clean).
- note 3** DOVDD is 1.7 - 3.0V of sensor digital IO power (clean). 1.8V is recommended.
- note 4** EVDD and DVDD is 1.2V ±5%.
- note 5** sensor AGND and DGND should be separated inside the module and connected to a single point outside the module (do not be connected inside module).
- note 6** capacitors should be close to their related sensor pins.
- note 7** EVDD/EGND are power/ground for MIPI core.
MCP and MCN are MIPI clock lane positive and negative output.
MDP0/MDP1 and MDN0/MDN1 are MIPI data lane positive and negative output.
- note 8** traces of MCP, MCN, MDPx, and MDNx should have the same or similar length.
differential impedance of the clock pair and data pair transmission line should be controlled at 100 Ohm.
- note 9** SID is SCCB slave address selection
when this pin pulled to ground, SCCB slave address is 0xC0.
when this pin pulled to DOVDD, SCCB slave address is 0x20.

9281_CSP5_D5_2.2

2.3 format and frame

The OV9281 supports RAW output with a 2-lane MIPI interface.

table 2-1 supported resolution and frame rate

format ^a	resolution	max frame rate	methodology	typical MIPI data rate
full resolution	1280x800	120 fps	full	2-lane @ 800Mbps
720p	1280x720	130 fps	cropping	2-lane @ 800Mbps
VGA	640x480	180 fps	cropping	2-lane @ 800Mbps
640x400	640x400	210 fps	4:1 sub-sampling	2-lane @ 800Mbps

a. all formats with minimum 4 dummy lines and 4 dummy pixels

2.3.1 MIPI interface

The OV9281 supports a one/two-lane MIPI transmitter interface with a data transfer rate of up to 800 Mbps per lane.

figure 2-3 MIPI timing

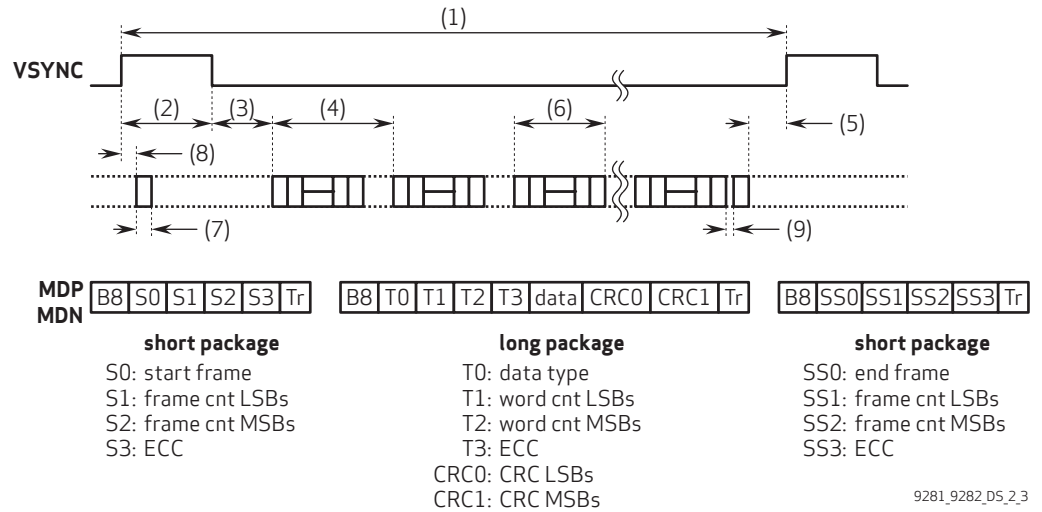

table 2-2 MIPI timing specifications (2-lane mode)

mode	timing
full resolution 1280x800	(1) 663,208 tp
	(2) 1,024 tp
	(3) 12,159 tp
	(4) 791 tp
	(5) 65,665 tp
	(6) 674 tp
	(7) 33 tp
	(8) -65 tp
	(9) 37 tp
where tp = Tscclk	
640x400	(1) 234,688 tp
	(2) 1,024 tp
	(3) 6,496 tp
	(4) 772 tp
	(5) 42,422 tp
	(6) 216 tp
	(7) 22 tp
	(8) -194 tp
	(9) 9 tp
where tp = Tscclk	

2.3.2 VSYNC timing in MIPI mode

The VSYNC rising edge delay is controlled by register `vsync_delay` (`{0x4314, 0x4315, 0x4316}`) in all three VSYNC modes. VSYNC width is controlled by register `vsync_width_pixel` (`{0x4311, 0x4312}`) for VSYNC modes 1 and 2. The steps of both registers `vsync_delay` and `vsync_width_pixel` are 1 system clock cycle.

Note that VSYNC timing in mode 3 is a long VSYNC mode. The register `vsync_width_pixel` (`{0x4311, 0x4312}`) controls VSYNC falling edge differently.

2.3.2.1 VSYNC mode 1

In mode 1, VSYNC is generated by the internal start of frame (SOF) signal (see [figure 2-4](#)).

figure 2-4 VSYNC timing in mode 1

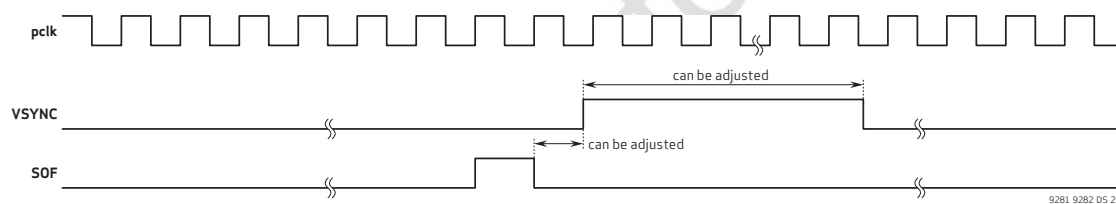

2.3.2.2 VSYNC mode 2

In mode 2, VSYNC is generated by the internal end of frame (EOF) signal (see [figure 2-5](#)).

figure 2-5 VSYNC timing in mode 2

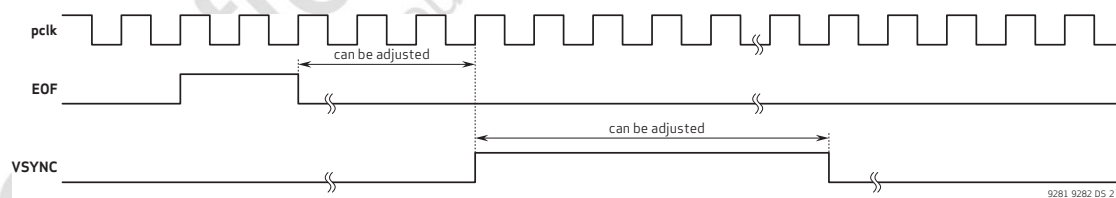

2.3.2.3 VSYNC mode 3

In mode 3, VSYNC is generated by EOF and SOF (see [figure 2-6](#)).

figure 2-6 VSYNC timing in mode 3

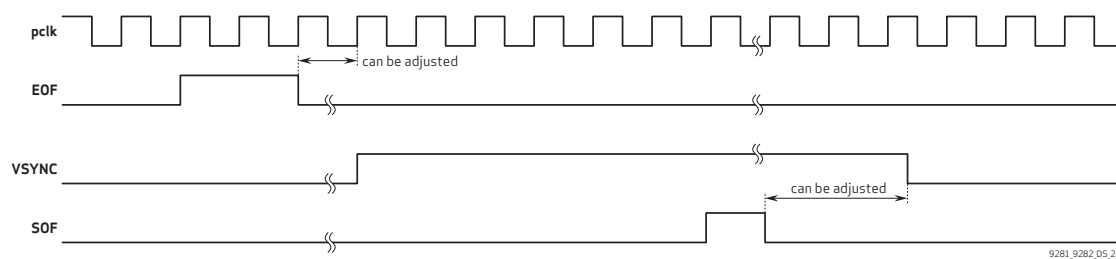

2.4 I/O control

table 2-3 I/O control registers

function	register	description
output drive capability control	0x3001	Bit[6:5]: I/O pin drive capability 00: 1x 01: 2x 10: 3x 11: 4x
STROBE I/O control	0x3006	Bit[3]: input/output control for STROBE pin 0: input 1: output
STROBE output select	0x3027	Bit[3]: output selection for STROBE pin 0: normal data path 1: register control value
STROBE output value	0x3009	Bit[3]: STROBE output value
ILPWM I/O control	0x3006	Bit[2]: input/output control for ILPWM pin 0: input 1: output
ILPWM output select	0x3027	Bit[2]: output selection for ILPWM pin 0: normal data path 1: register control value
ILPWM output value	0x3009	Bit[2]: PWM output value
FSIN/VSYN I/O control	0x3006	Bit[1]: input/output control for FSIN pin 0: input 1: output
FSIN/VSYN output select	0x3027	Bit[1]: output selection for FSIN pin 0: normal data path 1: register control value
FSIN/VSYN output value	0x3009	Bit[1]: FSIN output value

2.5 power management

2.5.1 power up sequence

The OV9281 has no internal regulator.

table 2-4 power up sequence

case	DVDD	XSHUTDOWN	power up sequence requirement
1	external	GPIO	Refer to figure 2-7 1. AVDD rising can occur before or after DOVDD rising as long as they are rising before XSHUTDOWN rising 2. XSHUTDOWN is pulled up after AVDD and DOVDD are stable 3. DVDD rises after DOVDD, but before XSHUTDOWN is pulled high

table 2-5 power up sequence timing constraints

constraint	label	min	max	unit
AVDD rising – DOVDD rising	t0	0	∞	ms
DOVDD rising – AVDD rising	t1			ms
AVDD or DOVDD rising, whichever is last – XSHUTDOWN rising	t2	1		ms
XSHUTDOWN rising – first SCCB transaction	t3	8192		XVCLK cycles
minimum number of XVCLK cycles prior to the first SCCB transaction	t4	8192		XVCLK cycles
PLL start up/lock time	t5		0.2	ms
entering streaming mode – first frame start sequence (fixed part)	t6		10	ms
entering streaming mode – first frame start sequence (variable part)	t7	delay is the exposure time value		lines
DOVDD to external DVD rising	t8	0		ms
DOVDD rising to XSHUTDOWN rising	t9	0		ms

figure 2-7 power up sequence

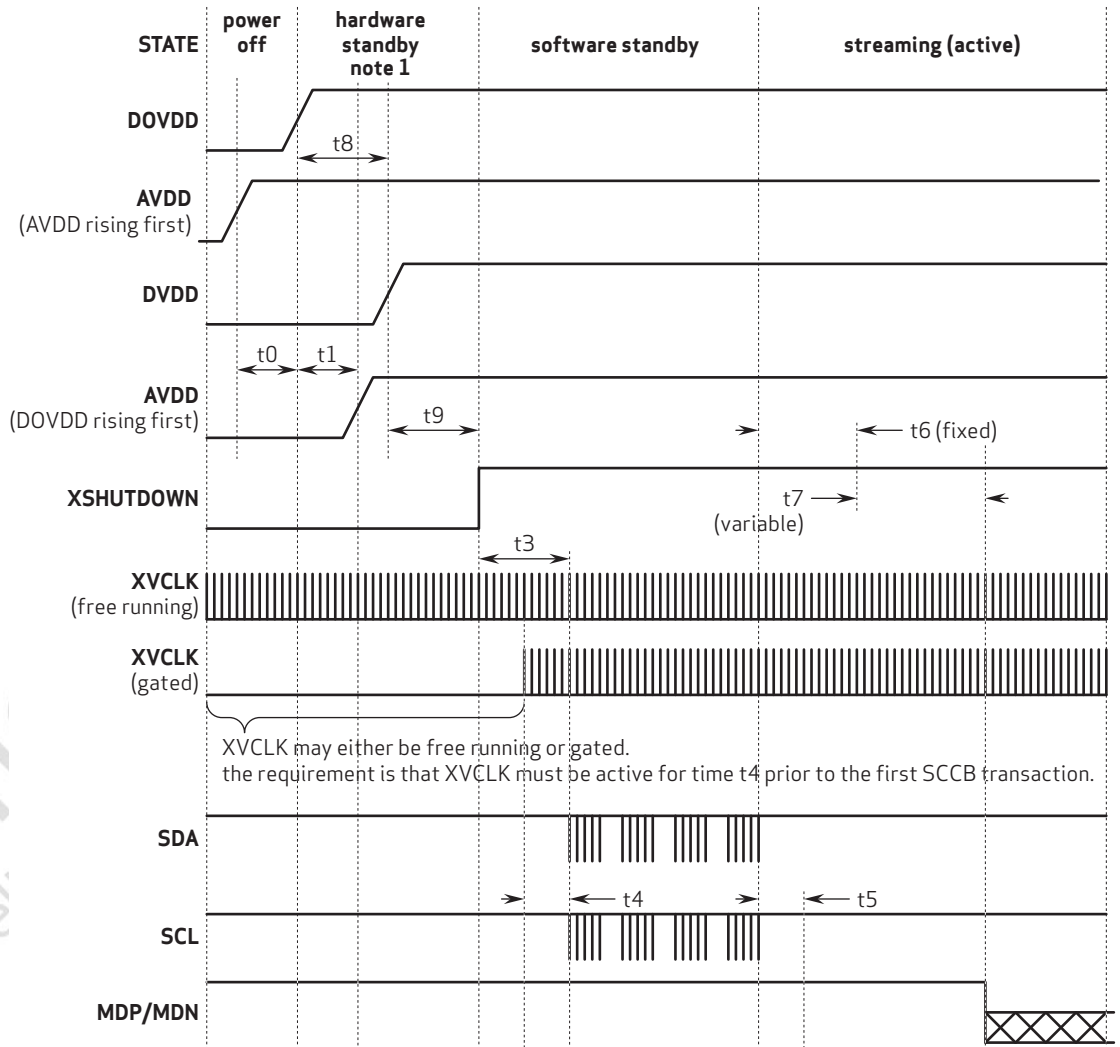

Confidential
honeywell

9281_9282_DS_2.7

2.5.2 power down sequence

The digital and analog supply voltages can be powered down in any order (e.g., DOVDD, then AVDD or AVDD, then DOVDD). Similar to the power-up sequence, the XVCLK input clock may be either gated or continuous. If the SCCB command to exit streaming is received while a frame of MIPI data is being output, then the sensor must wait to the MIPI frame end code before entering software standby mode.

If the SCCB command to exit streaming mode is received during the inter frame time, then the sensor will enter software standby mode immediately.

table 2-6 power down sequence

case	DVDD	XSHUTDOWN	power down sequence requirement
1	external	GPIO	Refer to figure 2-8 1. software standby recommended 2. pull XSHUTDOWN low for minimum power consumption 3. pull DVDD low 4. AVDD and DOVDD may fall in any order

table 2-7 power down sequence timing constraints

constraint	label	min	max	unit
enter software standby SCCB command device in software standby mode	t0			
				when a frame of MIPI data is output, wait for the MIPI end code before entering the software for standby; otherwise, enter the software standby mode immediately
minimum of XVCLK cycles after the last SCCB transaction or MIPI frame end	t1	512		XVCLK cycles
last SCCB transaction or MIPI frame end, XSHUTDOWN falling	t2	512		XVCLK cycles
XSHUTDOWN falling - AVDD falling or DOVDD falling whichever is first	t3	0.0		ms
AVDD falling - DOVDD falling	t4		AVDD and DOVDD may fall in any order, the falling separation can vary from 0 ns to infinity	ms
DOVDD falling - AVDD falling	t5			ms
XSHUTDOWN falling - DVDD falling	t6	0		ms
DVDD falling to DOVDD falling	t7	0		ms

figure 2-8 power down sequence

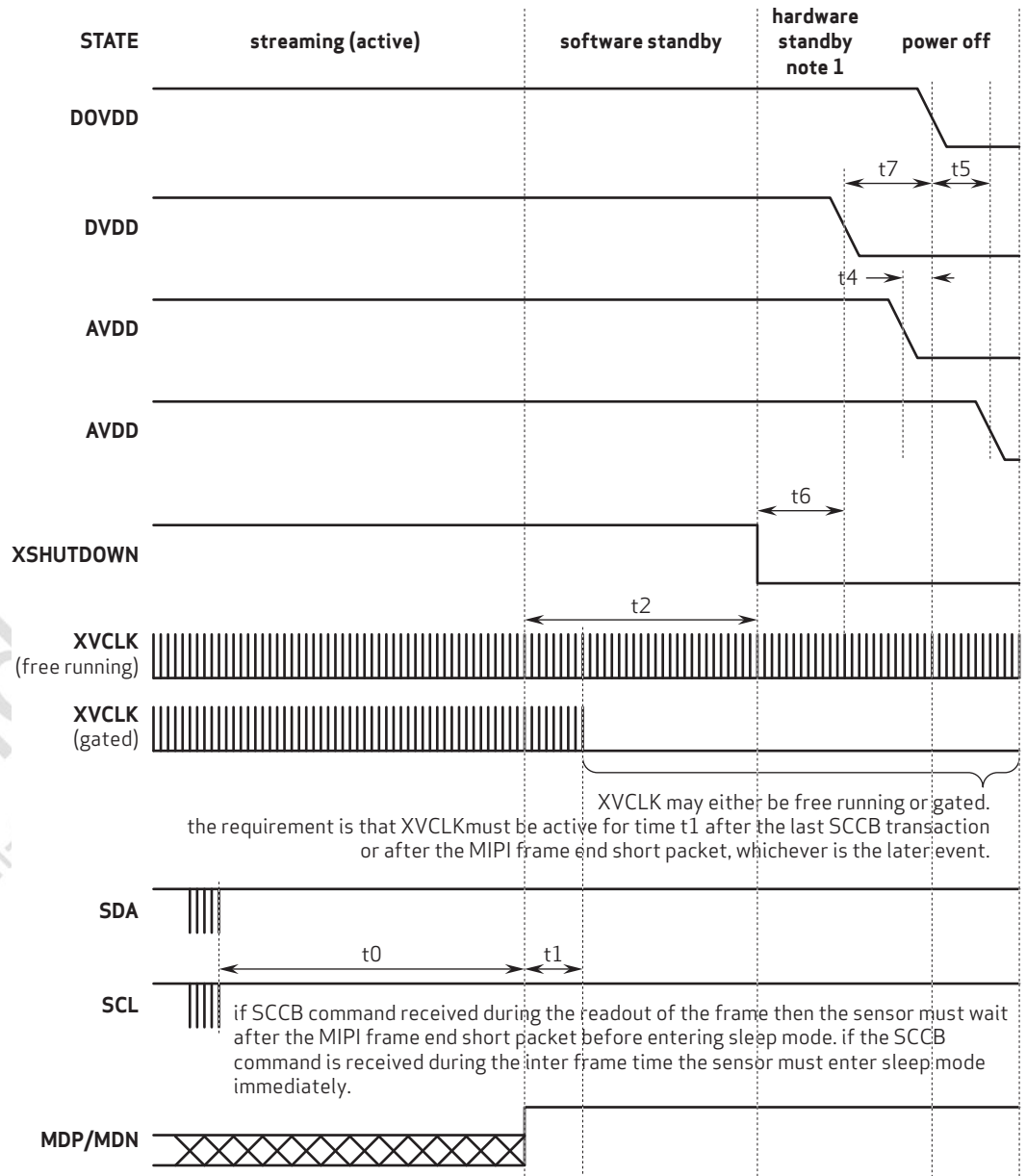

9281_9282_DS_2_8

figure 2-9 standby sequence

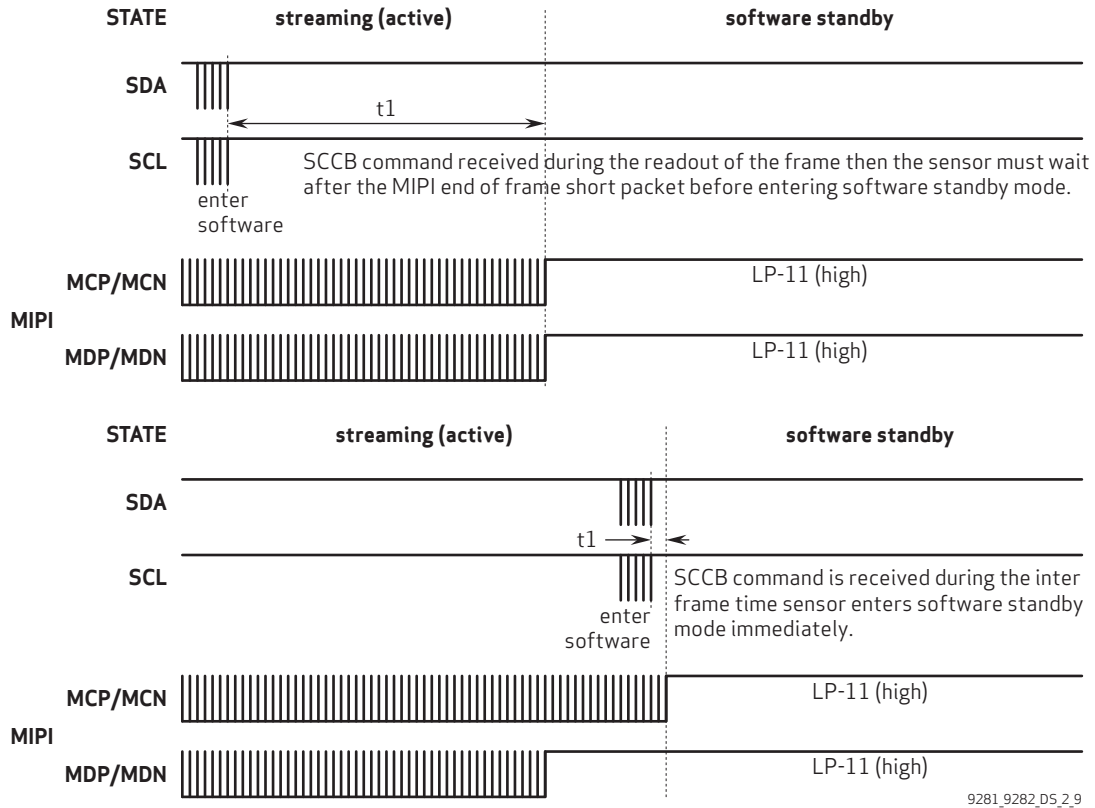

2.6 reset

The OV9281 sensor includes a XSHUTDOWN pin (pin **A5**) that forces a complete hardware reset when it is pulled low (GND). The OV9281 clears all registers and resets them to their default values when a hardware reset occurs.

2.6.1 power ON reset generation

The OV9281 has a power on reset that is generated after the core power becomes stable.

2.7 hardware and software standby

Two suspend modes are available for the OV9281:

- hardware standby
- software standby

table 2-8 hardware and software standby description

mode	description
hardware standby with XSHUTDOWN	<ol style="list-style-type: none"> 1. enabled by pulling XSHUTDOWN pad low 2. power down all blocks 3. register values are reset to default values 4. no SCCB communication 5. minimum power consumption
software standby	<ol style="list-style-type: none"> 1. default mode after power on reset 2. power down all blocks except SCCB 3. register values are maintained 4. SCCB communication is available 5. low power consumption 6. GPIO can be configured as high/low/tri-state

2.8 system clock control

The OV9281 has two on-chip PLLs which generate the system clock from a 6~27 MHz input clock. A programmable clock divider is provided to generate different frequencies for the system.

2.8.1 PLL configuration

PLL settings can only be changed during sensor standby mode (0x0100 = 0).

figure 2-10 PLL1 clock diagram

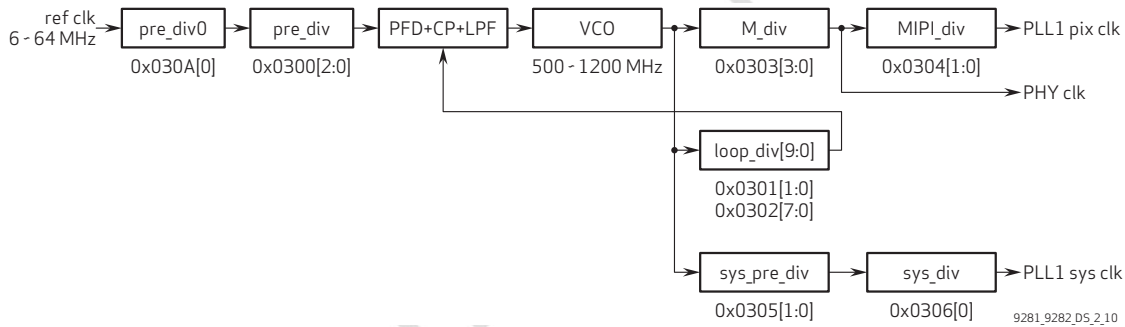

note

Contact your local OmniVision FAE for additional assistance on PLL configuration.

figure 2-11 PLL2 clock diagram

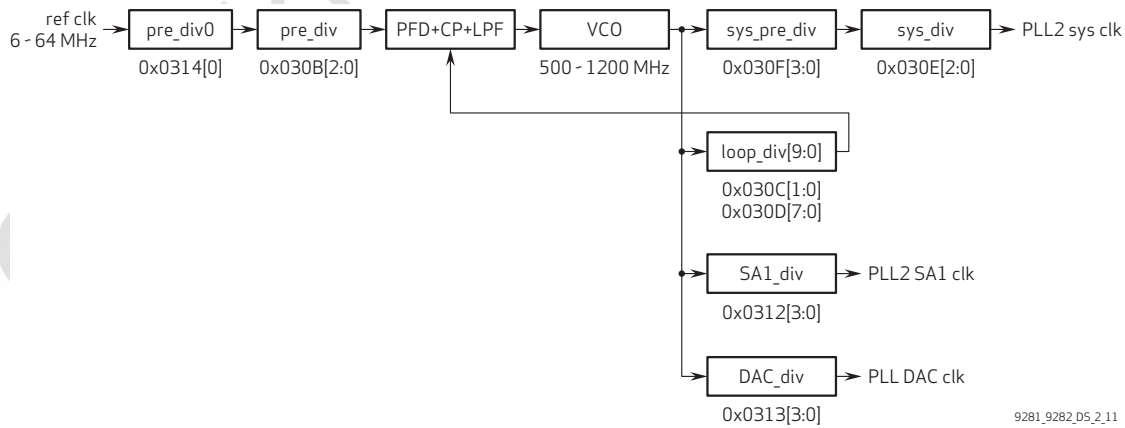

table 2-9 PLL control registers (sheet 1 of 2)

function	address	description
PLL1_pre_div0	0x030A	Bit[0]: PLL1 pre-divider 0 0: /1 1: /2
PLL1_pre_div	0x0300	Bit[2:0]: PLL1 pre divider 000: /1 001: /1.5 010: /2 011: /2.5 100: /3 101: /4 110: /6 111: /8
PLL1_loop_div	0x0301	Bit[1:0]: PLL1_loop_div[9:8]
PLL1_loop_div	0x0302	Bit[7:0]: PLL1_loop_div[7:0]
PLL1_sys_pre_div	0x0305	Bit[1:0]: PLL1 system pre-divider 00: /3 01: /4 10: /5 11: /6
PLL1_sys_div	0x0306	Bit[0]: PLL1 system divider 0: /1 1: /2
PLL1_M_div	0x0303	Bit[3:0]: PLL1_M_div / (1 + 0x0303[3:0])
PLL1_MIPI_div	0x0304	Bit[1:0]: PLL1 MIPI divider 00: /4 01: /5 10: /6 11: /8
PLL2_pre_div0	0x0314	Bit[0]: PLL2 pre-divider 0 0: /1 1: /1
PLL2_pre_div	0x030B	Bit[2:0]: PLL2 pre divider 000: /1 001: /1.5 010: /2 011: /2.5 100: /3 101: /4 110: /6 111: /8
PLL2_loop_div	0x030C	Bit[1:0]: PLL2_loop_div[9:8]
PLL2_loop_div	0x030D	Bit[7:0]: PLL2_loop_div[7:0]

table 2-9 PLL control registers (sheet 2 of 2)

function	address	description
PLL2_sys_pre_div	0x030F	Bit[3:0]: PLL2 system pre-divider / (1 + 0x030F[3:0])
PLL2_sys_div	0x030E	Bit[2:0]: PLL2 system divider 000: /1 001: /1.5 010: /2 011: /2.5 100: /3 101: /3.5 110: /4 111: /5
PLL2_DAC_div	0x0313	Bit[3:0]: PLL2 DAC divider / (1 + 0x0313[3:0])
PLL2_SA1_div	0x0312	Bit[3:0]: PLL2 SA1 divider / (1 + 0x0312[3:0])

table 2-10 sample PLL configuration^a (sheet 1 of 2)

name	address	value
PLL1_pre_div0	0x030A[0]	1'h0
PLL1_pre_div	0x0300[2:0]	3'h1
PLL1_loop_div[9:8]	0x0301[1:0]	2'h0
PLL1_loop_div[7:0]	0x0302[7:0]	8'h32
PLL1_sys_pre_div	0x0305[1:0]	2'h2
PLL1_sys_div	0x0306[0]	1'h1
PLL1_M_div	0x0303[3:0]	4'h0
PLL1_MIPI_div	0x0304[1:0]	2'h3
PLL2_pre_div0	0x0314[0]	1'h0
PLL2_pre_div	0x030B[2:0]	3'h4
PLL2_loop_div[9:8]	0x030C[1:0]	2'h0
PLL2_loop_div[7:0]	0x030D[7:0]	8'h50
PLL2_sys_pre_div	0x030F[3:0]	4'h3
PLL2_sys_div	0x030E[2:0]	3'h2
PLL2_DAC_div	0x0313[3:0]	4'h1
PLL2_SA1_div	0x0312[3:0]	4'h7

table 2-10 sample PLL configuration^a (sheet 2 of 2)

name	address	value
SYS_CLK		80 MHz
MIPI_PCLK		100 MHz
MIPI_CLK		800 Mbps
EXTCLK		24 MHz

a. PLL control for 1 megapixel @ 120 fps with 2-lane, 10-bit output

figure 2-12 clock connection diagram

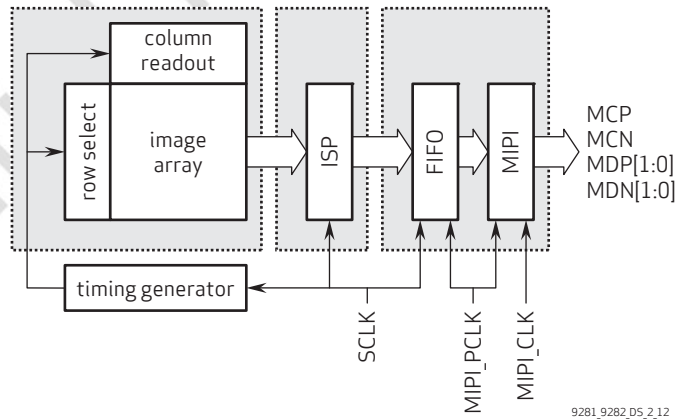

table 2-11 PLL speed limitation

parameter	value
PLL1_multiplier input	6~64 MHz
PLL1_multiplier output	500~1200 MHz
PLL2_multiplier input	6~64 MHz
PLL2_multiplier output	500~1200 MHz
SYS_CLK	up to 80 MHz

2.9 serial camera control bus (SCCB) interface

The Serial Camera Control Bus (SCCB) interface controls the image sensor operation. Refer to the *OmniVision Technologies Serial Camera Control Bus (SCCB) Specification* for detailed usage of the serial control port.

The OV9281 responds to two SCCB ID set by register SC_SCCB_ID1 (default 0xC0) and SC_SCCB_ID2 (default 0xE0). One of them can be used as a broadcasting ID and the other one can be programmed to a unique ID.

2.9.1 data transfer protocol

The data transfer of the OV9281 follows the SCCB protocol.

2.9.2 message format

The OV9281 supports the message format shown in **figure 2-13**. The repeated START (Sr) condition is not shown in SCCB single read from random location, but is shown in SCCB single read from current location and SCCB sequential read from random location.

figure 2-13 message type

message type: 16-bit sub-address, 8-bit data, and 7-bit slave address

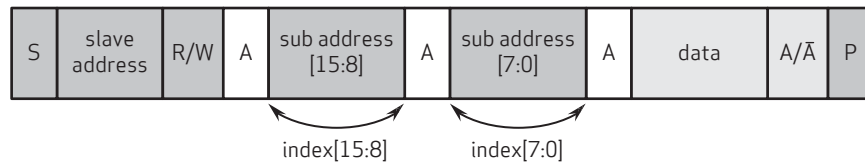

from slave to master

from master to slave

direction depends on operation

S START condition

P STOP condition

Sr repeated START condition

A acknowledge

Ā negative acknowledge

9281_9282_DS_2_13

2.9.3 read / write operation

The OV9281 supports four different read operations and two different write operations:

- a single read from random locations
- a sequential read from random locations
- a single read from current location
- a sequential read from current location
- single write to random locations
- sequential write starting from random location

The sub-address in the sensor automatically increases by one after each read/write operation.

In a single read from random locations, the master does a dummy write operation to desired sub-address, issues a repeated start condition and then addresses the camera again with a read operation. After acknowledging its slave address, the camera starts to output data onto the SDA line as shown in **figure 2-14**. The master terminates the read operation by setting a negative acknowledge and stop condition.

figure 2-14 SCCB single read from random location

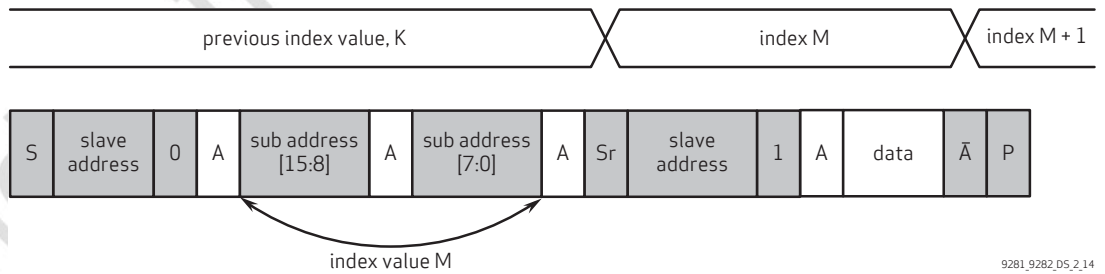

9281_9282_05_2_14

If the host addresses the camera with read operation directly without the dummy write operation, the camera responds by setting the data from last used sub-address to the SDA line as shown in **figure 2-15**. The master terminates the read operation by setting a negative acknowledge and stop condition.

figure 2-15 SCCB single read from current location

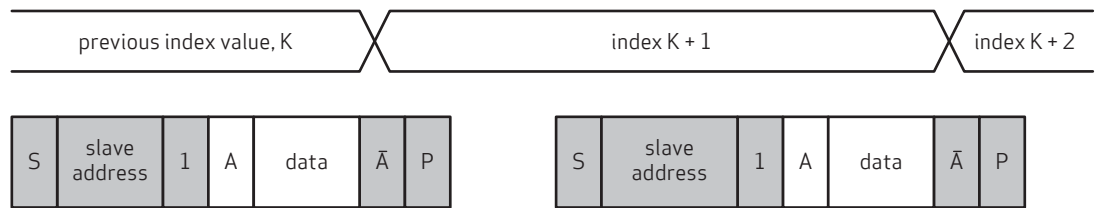

9281_9282_05_2_15

The sequential read from a random location is illustrated in **figure 2-16**. The master does a dummy write to the desired sub-address, issues a repeated start condition after acknowledge from slave and addresses the slave again with read operation. If a master issues an acknowledge after receiving data, it acts as a signal to the slave that the read operation shall continue from the next sub-address. When master has read the last data byte, it issues a negative acknowledge and stop condition.

figure 2-16 SCCB sequential read from random location

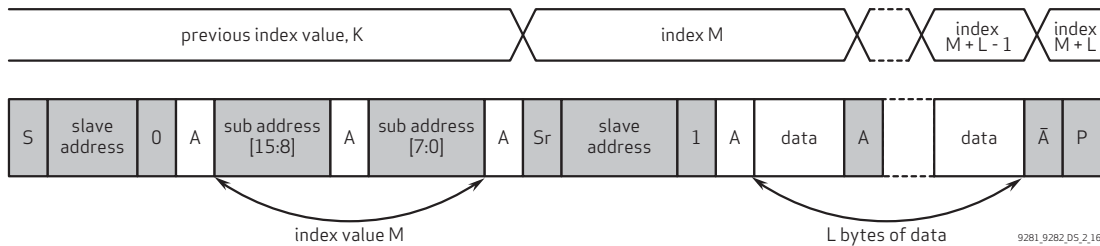

The sequential read from current location is similar to a sequential read from a random location. The only exception is that there is no dummy write operation, as shown in **figure 2-17**. The master terminates the read operation by setting a negative acknowledge and stop condition.

figure 2-17 SCCB sequential read from current location

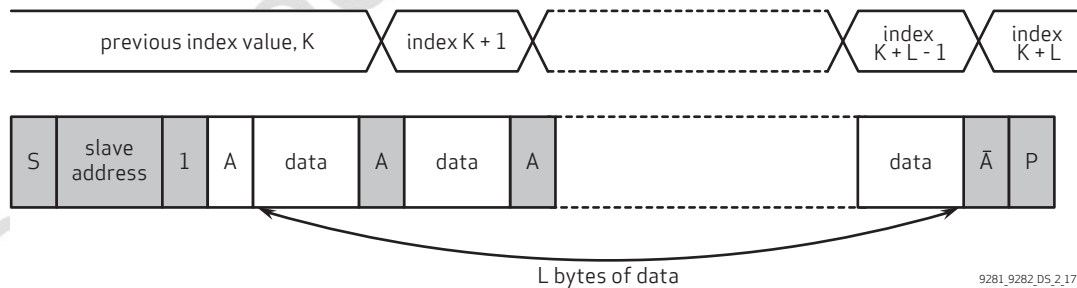

The write operation to a random location is illustrated in **figure 2-18**. The master issues a write operation to the slave, sets the sub-address and data correspondingly after the slave has acknowledged. The write operation is terminated with a stop condition from the master.

figure 2-18 SCCB single write to random location

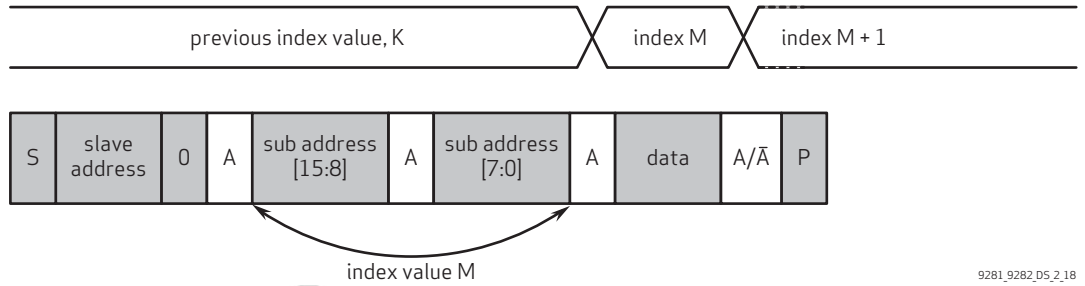

The sequential write is illustrated in **figure 2-19**. The slave automatically increments the sub-address after each data byte. The sequential write operation is terminated with stop condition from the master.

figure 2-19 SCCB sequential write to random location

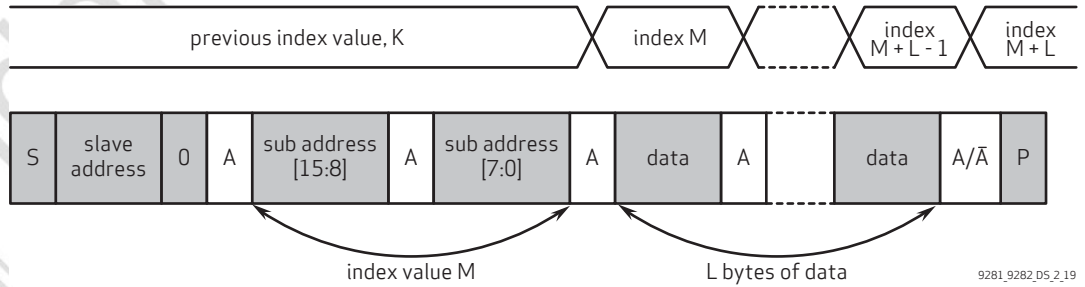

2.9.4 SCCB timing

figure 2-20 SCCB interface timing

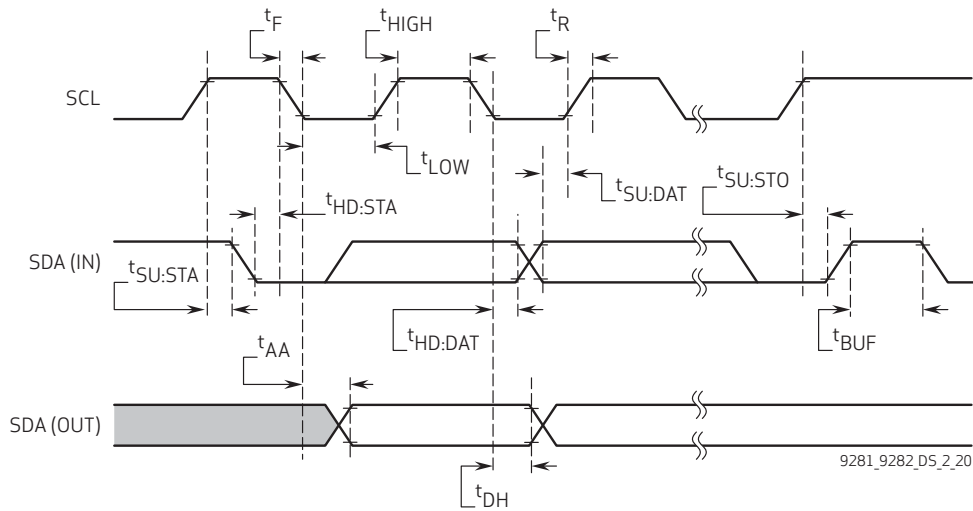

table 2-12 SCCB interface timing specifications^{ab}

symbol	parameter	min	typ	max	unit
f_{SCL}	clock frequency			400	kHz
t_{LOW}	clock low period	1.3			μs
t_{HIGH}	clock high period	0.6			μs
t_{AA}	SCL low to data out valid	0.1		0.9	μs
t_{BUF}	bus free time before new start	1.3			μs
$t_{HD:STA}$	start condition hold time	0.6			μs
$t_{SU:STA}$	start condition setup time	0.6			μs
$t_{HD:DAT}$	data in hold time	0			μs
$t_{SU:DAT}$	data in setup time	0.1			μs
$t_{SU:STO}$	stop condition setup time	0.6			μs
t_R, t_F	SCCB rise/fall times			0.3	μs
t_{DH}	data out hold time	0.05			μs

a. SCCB timing is based on 400kHz mode

b. timing measurement shown at the beginning of the rising edge or the end of the falling edge signifies 30%, timing measurement shown in the middle of the rising/falling edge signifies 50%, timing measurement shown at the beginning of the falling edge or the end of the rising edge signifies 70%

2.9.5 group write and fast mode switching

Group write is supported in order to update a group of registers in the same frame. These registers are guaranteed to be written prior to the internal latch at the frame boundary. Group write can be used to switch modes quickly.

table 2-13 context switching control

address	register name	default value	R/W	description
0x3208	GROUP_ACCESS	–	W	Group Access Bit[7:4]: group_ctrl 0000: Group hold start 0001: Group hold end 1010: Group launch 1110: Immediate launch others: Reserved Bit[3:0]: group_id 0000: Group bank 0, default start from address 0x00 0001: Group bank 1, default start from address 0x40 others: Reserved
0x3209	GRP0_PERIOD	0x00	RW	Frames For Staying in Group 0
0x320A	GRP1_PERIOD	0x00	RW	Frames For Staying in Group 1
0x320B	GRP_SWCTRL	0x01	RW	Bit[3]: group_switch_repeat Bit[2]: Group switch enable Bit[1:0]: Second group selection
0x320D	GRP_ACT	–	R	Indicates Which Group is Active
0x320E	FRAME_CNT_GRP0	–	R	frame_cnt_grp0
0x320F	FRAME_CNT_GRP1	–	R	frame_cnt_grp1

3 block level description

3.1 pixel array structure

The OV9281 sensor has an image array of 1296 columns by 816 rows (1,057,536 pixels). **figure 3-1** shows a cross-section of the image sensor array.

Of the 1,057,536 pixels, 1,024,000 (1280x800) are active pixels and can be output. The other pixels are used for black level calibration and interpolation.

figure 3-1 sensor array region color filter layout

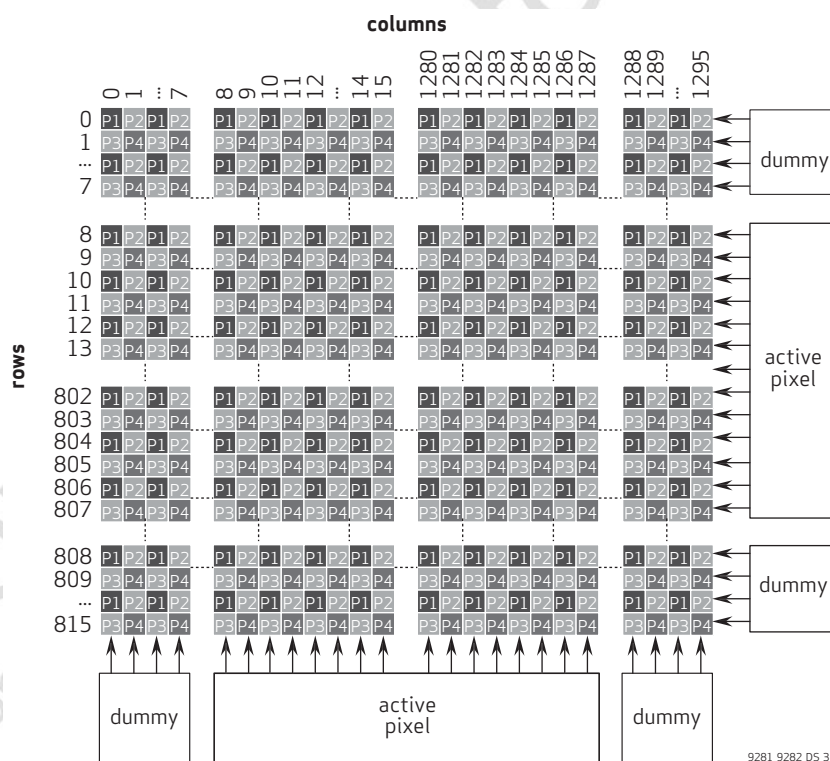

3.2 subsampling

There are two subsampling modes in the OV9281: binning and skipping. Both are acceptable methods of reducing output resolution while maintaining the field of view. Binning is usually preferred as it increases the pixel's signal-to-noise ratio. When the binning function is ON, voltage levels of a pair of the same pixels (e.g., P1 and P1 pixels, or P2 and P2 pixels) are averaged. In skipping mode (binning function is OFF), alternate pixels, which are not output, are merely skipped. The OV9281 supports 2x2 binning. **figure 3-2** illustrates 2x2 binning, where the voltage levels of two horizontal (2x1) pixels, which are the same, such as P3 and P3 pixels are averaged.

figure 3-2 example of 2x2 binning

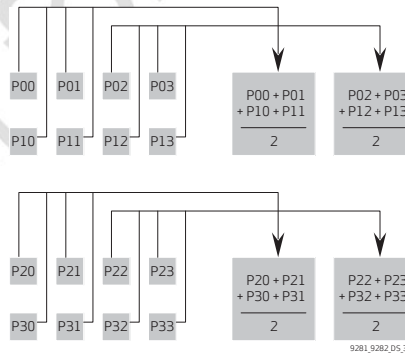

figure 3-3 example of 2:1 skipping

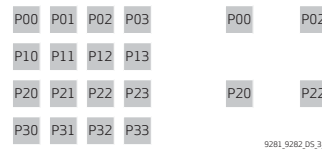

figure 3-4 example of 4:1 skipping



table 3-1 binning-related registers

address	register name	default value	R/W	description
0x3820	TIMING_FORMAT1	0x00	RW	Bit[1]: Vertical binning
0x3821	TIMING_FORMAT2	0x00	RW	Bit[0]: Horizontal binning

4 image sensor core digital functions

4.1 mirror and flip

The OV9281 provides mirror and flip readout modes, which respectively reverse the sensor data readout order horizontally and vertically (see [figure 4-1](#)).

figure 4-1 mirror and flip samples

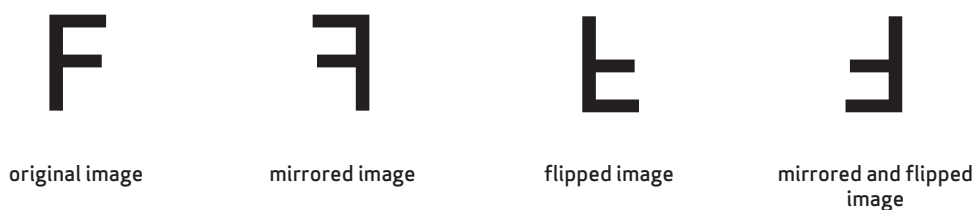

9281_9282_D5_4_1

table 4-1 mirror and flip registers

address	register name	default value	R/W	description
0x3820	IMAGE_ORIENTATION	0x00	RW	Timing Control Register Bit[2]: Vertical flip enable 0: Normal 1: Vertical flip
0x3821	IMAGE_ORIENTATION	0x00	RW	Timing Control Register Bit[2]: Horizontal mirror enable 0: Normal 1: Horizontal mirror

4.2 image windowing

An image windowing area is defined by four parameters, horizontal start (HS), horizontal end (HE), vertical start (VS), and vertical end (VE). By properly setting the parameters, any portion within the sensor array size can output as a visible area. Windowing is achieved by simply masking off the pixels outside of the window; thus, the timing is not affected.

figure 4-2 image windowing

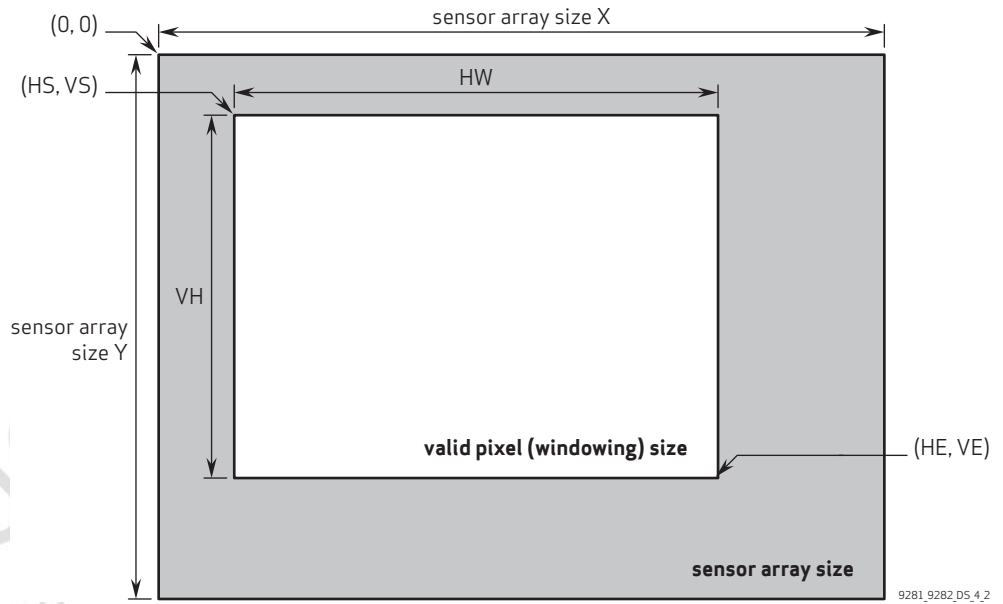

table 4-2 image windowing control functions

function	register	R/W	description
horizontal start	{0x3800, 0x3801}	RW	HS[9:8] = 0x3800 HS[7:0] = 0x3801
vertical start	{0x3802, 0x3803}	RW	VS[9:8] = 0x3802 VS[7:0] = 0x3803
horizontal end	{0x3804, 0x3805}	RW	HE[9:8] = 0x3804 HE[7:0] = 0x3805
vertical end	{0x3806, 0x3807}	RW	VE[9:8] = 0x3806 VE[7:0] = 0x3807

4.3 test pattern

For testing purposes, the OV9281 offers three test patterns:

4.3.1 general test pattern bar

figure 4-3 test pattern

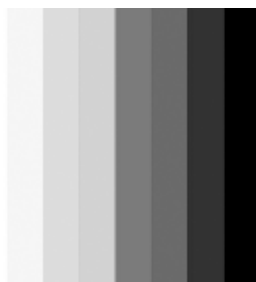

table 4-3 general test pattern bar selection control

function	register	default value	R/W	description
general test pattern bar	0x5E00	0x00	RW	Bit[7]: Test pattern bar enable

4.3.2 solid color test pattern

table 4-4 solid color test pattern control (sheet 1 of 2)

function	register	default value	R/W	description
solid test pattern	0x4320	0x80	RW	Bit[7:6]: Pixel order 00: P3P4/P1P2 01: P4P3/P2P1 10: P1P2/P3P4 11: P2P1/P4P3 Bit[1]: Solid test pattern enable 0: Solid test pattern OFF 1: Solid test pattern enable Bit[0]: Debug control
solid pattern P1	0x4322	0x00	RW	Bit[1:0]: solid_testpattern_P1[9:8]
solid pattern P1	0x4323	0x00	RW	Bit[7:0]: solid_testpattern_P1[7:0]
solid pattern P2	0x4324	0x00	RW	Bit[1:0]: solid_testpattern_P2[9:8]
solid pattern P2	0x4325	0x00	RW	Bit[7:0]: solid_testpattern_P2[7:0]

table 4-4 solid color test pattern control (sheet 2 of 2)

function	register	default value	R/W	description
solid pattern P4	0x4326	0x00	RW	Bit[1:0]: solid_testpattern_P4[9:8]
solid pattern P4	0x4327	0x00	RW	Bit[7:0]: solid_testpattern_P4[7:0]
solid pattern P3	0x4328	0x00	RW	Bit[1:0]: solid_testpattern_P3[9:8]
solid pattern P3	0x4329	0x00	RW	Bit[7:0]: solid_testpattern_P3[7:0]

4.4 black level calibration (BLC)

The pixel array contains several optically shielded (black) lines. These lines are used as reference for black level calibration.

Black level adjustments can be made with registers 0x4000, 0x4001, 0x4002, 0x4003, 0x4004 and 0x4009.

table 4-5 BLC control functions (sheet 1 of 2)

address	register name	default value	R/W	description
0x5000	ISP_CTRL00	0x9F	RW	Bit[0]: BLC enable 0: Disable 1: Enable
0x4000	BLC_CTRL_00	0xCF	RW	Bit[7:4]: r_off_avg_weight_o Bit[3]: r_target_adj_dis_o Bit[2]: r_off_cmp_en_o Bit[1]: r_dither_en_o Bit[0]: r_mf_en_o
0x4001	BLC_CTRL_01	0x20	RW	Bit[7:6]: r_hdr_option_o Bit[5]: r_kcoef_man_en_o Bit[4]: r_off_man_en_o Bit[3]: r_zero_in_out_en_o Bit[2]: r_blk_in_out_en_o Bit[1:0]: r_byp_mode_o
0x4002	BLC_AUTO	0x00	RW	Bit[7:3]: Reserved Bit[2:0]: Black target level[10:8]
0x4003	BLC_CTRL_03	0x10	RW	Bit[7:0]: Black target level[7:0]
0x4008	BLC_CTRL_08	0x00	RW	Bit[7:4]: Reserved Bit[3:0]: r_up_bl_start_o[3:0]
0x4009	BLC_CTRL_09	0x07	RW	Bit[7:4]: Reserved Bit[3:0]: r_up_bl_end_o[3:0]
0x400C	BLC_CTRL_0C	0x00	RW	Bit[7:4]: Reserved Bit[3:0]: r_dn_bl_start_o[3:0]

table 4-5 BLC control functions (sheet 2 of 2)

address	register name	default value	R/W	description
0x400D	BLC_CTRL_0D	0x07	RW	Bit[7:4]: Reserved Bit[3:0]: r_dn_bl_end_o[3:0]
0x4010	BLC_CTRL_10	0x41	RW	Bit[7]: r_up_off_trig_en_o Bit[6]: r_gain_chg_trig_en_o Bit[5]: r_fmt_chg_trig_en_o Bit[4]: r_rst_trig_en_o Bit[3]: r_man_avg_en_o Bit[2]: r_man_trig_o Bit[1]: r_off_frz_en_o Bit[0]: r_off_always_up_o
0x4011	BLC_CTRL_11	0x7F	RW	Bit[7]: Reserved Bit[6]: r_off_chg_mf_en_o Bit[5]: r_fmt_chg_mf_en_o Bit[4]: r_gain_chg_mf_en_o Bit[3]: r_rst_mf_mode_o Bit[2]: r_off_chg_mf_mode_o Bit[1]: r_off_chg_mf_mode_o Bit[0]: r_gain_chg_mf_mode_o

table 4-6 ALS algorithm control registers (sheet 1 of 3)

address	register name	default value	R/W	description
0x4E00	ALS_CTRL_00	0x00	RW	Bit[5]: Range level adjust enable 0: Disable 1: Enable Bit[4]: Merge average option enable 0: Disable 1: Enable Bit[3]: Merge enable 0: Disable 1: Enable Bit[2]: Reserved Bit[1]: Select abs value enable 0: Disable 1: Enable Bit[0]: ALS enable 0: Disable 1: Enable
0x4E01	ALS_CTRL_01	0x01	RW	Bit[7]: Clock select Bit[6:0]: Sample period intervals
0x4E02	ALS_CTRL_02	0x00	RW	Bit[7:0]: Manual threshold[15:8]
0x4E03	ALS_CTRL_03	0x00	RW	Bit[7:0]: Manual threshold[7:0]

table 4-6 ALS algorithm control registers (sheet 2 of 3)

address	register name	default value	R/W	description
0x4E04	ALS CTRL 04	0x00	RW	Bit[7:0]: Small zone manual threshold[15:8]
0x4E05	ALS CTRL 05	0x00	RW	Bit[7:0]: Small zone manual threshold[7:0]
0x4E06	ALS CTRL 06	0x00	RW	Bit[7:0]: Large zone manual threshold[15:8]
0x4E07	ALS CTRL 07	0x00	RW	Bit[7:0]: Large zone manual threshold[7:0]
0x4E08	ALS CTRL 08	0x00	RW	Bit[0]: Threshold manual enable 0: Disable 1: Enable
0x4E09	ALS CTRL 09	0x00	RW	Bit[7:0]: Percentage step
0x4E0A	ALS CTRL 0A	0x00	RW	Bit[7:0]: Light meter x0[15:8]
0x4E0B	ALS CTRL 0B	0x00	RW	Bit[7:0]: Light meter x0[7:0]
0x4E0C	ALS CTRL 0C	0xFF	RW	Bit[7:0]: Light meter x1[15:8]
0x4E0D	ALS CTRL 0D	0xFF	RW	Bit[7:0]: Light meter x1[7:0]
0x4E0E	ALS CTRL 0E	0x00	RW	Bit[7:0]: Analog register control[15:8]
0x4E0F	ALS CTRL 0F	0x23	RW	Bit[7:0]: Analog register control[7:0]
0x4E10	ALS CTRL 10	0x9A	RW	Bit[7]: Interrupt trigger enable 0: Disable 1: Enable Bit[6]: Reserved Bit[5]: Interrupt_sel Bit[4]: ready_intr_pol Bit[3]: threshold_intr_pol Bit[2]: Reserved Bit[1]: Out range interrupt enable Bit[0]: Host clear format
0x4E11	ALS CTRL 11	0x02	RW	Bit[7]: Ready_opt Bit[6:0]: Mask period number
0x4E12	ALS CTRL 12	0x01	RW	Bit[7:0]: Interrupt number control interrupt width
0x4E20	ALS CTRL 20	–	R	Bit[6:2]: Range adjust Bit[1]: Reserved Bit[0]: Light meter zone1
0x4E21	ALS CTRL 21	–	R	Zone 1 Light Meter Statistics High Byte
0x4E22	ALS CTRL 22	–	R	Zone 1 Light Meter Statistics Low Byte
0x4E23~ 0x4E24	RSVD	–	–	Reserved
0x4E25	ALS CTRL 25	–	R	Zone 1 Light Meter Statistics High Byte
0x4E26	ALS CTRL 26	–	R	Zone 1 light Meter Statistics Low Byte

table 4-6 ALS algorithm control registers (sheet 3 of 3)

address	register name	default value	R/W	description
0x4E27~ 0x4E28	RSVD	–	–	Reserved
0x4E29	ALS CTRL 29	–	R	Bit[3]: Out range input Bit[2]: Trigger all Bit[1]: Reserved Bit[0]: Zone 1 trigger
0x4E2A	ALS CTRL 2A	–	R	Bit[3]: poll_thre_i Bit[2]: poll_rdy_i Bit[1]: intr_thres_i Bit[0]: intr_rdy_i
0x4E30	ALS CTRL 30	–	RW	Bit[1]: host clear[1] host_rdy_clear Bit[0]: host clear[0] host_thres_clear

4.5 one time programmable (OTP) memory

The OV9281 has 256-bit embedded one time programmable (OTP) memory. The OTP memory can be programmed and read back via SCCB bus. This document provides general guidelines for programming and accessing the OTP memory.

4.5.1 OTP memory structure

128 bits of OTP memory are reserved for OmniVision internal use. These bits are usually used to store the production information or used by some internal functions. The remaining 127 bits are fully user programmable. The user can store production tracking information, camera module calibration data, etc. to these bits.

table 4-7 OTP memory structure

OTP bits	function
[127:0]	reserved by OmniVision for internal use
[128]	OTP write disable
[255:129]	user programmable

4.5.2 accessing the OTP memory

The OTP memory cannot be directly accessed. Instead, it is accessed through its register buffer 0x3D00~0x3D1F as shown in **figure 4-4**. Registers 0x3D80 and 0x3D81 are the command registers to program values to and read values back from OTP memory.

When 0x01 is programmed to register 0x3D81, the OTP memory controller will load the content of all OTP memory bits to its corresponding register buffer. After that, the user can read the OTP content from its register buffer. It is recommended to clear the register buffer to zero before loading the OTP.

When value 0x01 is programmed to register 0x3D80, the OTP memory controller will program the data of register 0x3D00~0x3D1F to its corresponding OTP memory bits. Keep in mind, the memory is one time programmable. It cannot be programmed back to 0 once it is programmed to 1. In fact, the OTP memory controller only programs those bits with value 1 in its corresponding memory buffer when programming command is issued. Multi-pass programming is allowed. However, programming 1 to an OTP bit that is already programmed to 1 in previous pass is prohibited. The user should always program a bit from 0 to 1 only in any programming pass.

When register 0x3D10[0] (corresponding to [128] in OTP memory) is programmed to 1 through the SCCB or loaded from OTP (please note that waking up OV9281 will automatically load OTP to buffer), all register buffers (0x3D00~0x3D1F) writing operations are disabled. This is a security feature in the OV9281 which can protect OTP from a potential hacking breach. Please be advised that you can still burn OTP memory by programming register 0x3D80 to 0x01 even if register 0x3D10[0] is set to 1.

OTP access is in system clock domain, so register 0x100 has to be set to 1 to enable system clock PLL in order to access OTP. The OTP programming pulse width is controlled by register 0x3D82 and the unit is 8 system clock periods. The default value of 0x65 is for a 48MHz system clock and the programming pulse width is 16.8 μ s. The OTP read pulse width is set by register 0x3D83 and the default value of 0x05 gives 104ns at 48MHz system clock. When the system clock frequency is different, the programming pulse should set to the closest value to 10 μ s and should be greater than 9 μ s. The system clock frequency is dependent on the input clock and PLL configuration. Refer to [section 2.8](#) for details.

When the OTP memory controller is programming data to OTP memory or reading data from OTP memory, the sensor will not respond to any SCCB access. Because OTP programming current is quite high, accessing sensor register is prohibited in order to prevent any glitch on the power supply. It is recommended to wait 15ms after issuing the OTP read and program command. This delay should be scaled with the system clock period.

figure 4-4 OTP access

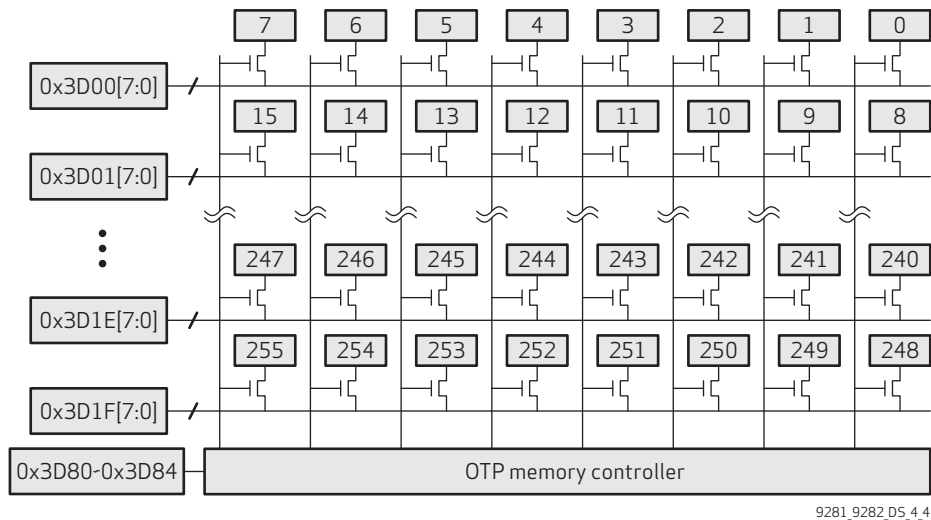

9281_9282_DS_4_4

4.5.3 procedure for accessing OTP memory

Since the OTP memory can only be programmed once, the user should be very careful when accessing the OTP. Here is a detailed procedure for OTP access.

4.5.4 procedure to read OTP content

1. Clear software buffer which is to receive the OTP content.
2. Configure PLL and set register 0x100 to 1 if not yet set.
3. Clear register buffer 0x3D00~0x3D1F to 0x00.
4. Set register 0x3D81 to 0x01.
5. Wait 15ms.
6. Read register 0x3D00~0x3D1F and set to the software buffer.

The OTP read operation is performed to verify the OTP memory is blank before program data to it, or to verify OTP contents after programming data to it.

Verifying the OTP content at the last step of camera module testing is highly recommended in case the OTP content is accidentally overwritten during the module testing.

4.5.5 procedure to program OTP content

1. Follow **procedure to read OTP content** to make sure the OTP to be programmed is blank.
2. Program the intended OTP content to its corresponding register buffer, and clear unused register buffer to 0.
 - a. For customer - registers 0x3D00~0x3D0F must be cleared to 0x00 before initiating the OTP programming command
3. Read back registers 0x3D00~0x3D1F to make sure they are the correct data to program to OTP memory or 0 for all other bits.
4. Write 0x01 to register 0x3D80 to initiate OTP programming.

5. Wait 15ms, any register access during this period is prohibited.
6. Follow **procedure to read OTP content** to read back the OTP content.
7. Compare the OTP content read back to the intended OTP content.

4.5.6 power supply requirement for OTP memory programming

The OTP memory is programmed using the analog power. The AVDD voltage for OTP programming must be 2.6V ~ 3.0V. The power supply should be able to provide extra 50mA for OTP programming.

4.6 LED PWM

The LED PWM driver is used to turn on an LED indicator light when the camera is transmitting image data. The driver uses pad clock input from 6~27MHz and drives LED to be active when the OV9281 image sensor is outputting image data. The output frequency of LED PWM driver can be adjusted by LED_FREQ_DIV_CYCLE from 1k to 100kHz and the duty cycle of the output can be adjusted from 0~100% by setting the DUTY_CYCLE_REG register from 0~65535. Minimum duty cycle can also be limited by register LED_DUTY_CYCLE_LOW.

The following parameter setting is stored in OTP memory:

- LED_DUTY_CYCLE_LOW: (16-bit) minimum duty cycle output
- LED_FREQ_DIV_CYCLE: (16-bit) LED driver output frequency divider

The LED PWM output is calculated as follows:

- $LED_FREQ = INPUT_PAD_CLK_FREQ / LED_FREQ_DIV_CYCLE$
- $LED_OUTPUT_CYCLE = LED_FREQ_DIV_CYCLE \times DUTY_CYCLE_REG / 65535$

LED_PWM pin is a dedicated output pin and can only be tri-state in XSHUTDOWN mode for security. The pin will drive low in software standby (sleep) and hardware standby (power down) mode.

figure 4-5 LED PWM output timing

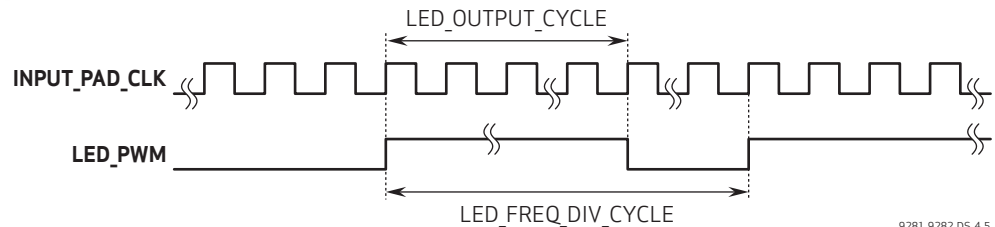

9281_9282_D5_4_5

table 4-8 LED PWM registers

address	register name	default value	R/W	description
0x3912	DUTY CYCLE REG	0x08	RW	Bit[7:0]: Desirable duty cycle from 0~100% for LED_PWM output[15:8] Range: 0~65535
0x3913	LED_PWM_REG03	0x00	RW	Bit[7:0]: Desirable duty cycle from 0~100% for LED_PWM output[7:0] Range: 0~65535

table 4-9 non-volatile memory map table (OTP)

OTP address	description
0x3D0A	Bit[7:0]: LED_FREQ_DIV_CYCLE[15:8]
0x3D0B	Bit[7:0]: LED_FREQ_DIV_CYCLE[7:0]
0x3D08	Bit[7:0]: LED_DUTY_CYCLE_LOW[15:8]
0x3D09	Bit[7:0]: LED_DUTY_CYCLE_LOW[7:0]

4.7 strobe

Strobe facilitates implementation of a flashlight. Strobe generates a pulse with a reference starting point at the time when the pixel array starts integration. Following a delay after the reference starting point, which is controlled by `strobe_frame_shift_direction`, `strobe_frame_shift[30:0]`, a pulse with a width of `strobe_frame_span[31:0]` is generated. The step width of shift and span is programmable under system clock domain.

table 4-10 strobe control registers (sheet 1 of 2)

address	register name	default value	R/W	description
0x3921	PWM_CTRL_21	0x00	RW	Bit[7]: Shift direction Bit[6:0]: <code>strobe_frame_shift[30:24]</code>
0x3922	PWM_CTRL_22	0x00	RW	Bit[7:0]: <code>strobe_frame_shift[23:16]</code>
0x3923	PWM_CTRL_23	0x00	RW	Bit[7:0]: <code>strobe_frame_shift[15:8]</code>
0x3924	PWM_CTRL_24	0x05	RW	Bit[7:0]: <code>strobe_frame_shift[7:0]</code>
0x3925	PWM_CTRL_25	0x00	RW	Bit[7:0]: <code>strobe_frame_span[31:24]</code>
0x3926	PWM_CTRL_26	0x00	RW	Bit[7:0]: <code>strobe_frame_span[23:16]</code>

table 4-10 strobe control registers (sheet 2 of 2)

address	register name	default value	R/W	description
0x3927	PWM_CTRL_27	0x00	RW	Bit[7:0]: strobe_frame_span[15:8]
0x3928	PWM_CTRL_28	0x1A	RW	Bit[7:0]: strobe_frame_span[7:0]
0x3929	PWM_CTRL_29	0x01	RW	Bit[7:0]: r_strobe_row_st[15:8]
0x392A	PWM_CTRL_2A	0xB4	RW	Bit[7:0]: r_strobe_row_st[7:0]
0x392B	PWM_CTRL_2B	0x00	RW	Bit[7:0]: r_strobe_cs_st[15:8]
0x392C	PWM_CTRL_2C	0x10	RW	Bit[7:0]: r_strobe_cs_st[7:0]
0x392D	PWM_CTRL_2D	0x05	RW	Bit[7:0]: step_onerow_man[15:8]
0x392E	PWM_CTRL_2E	0xF2	RW	Bit[7:0]: step_onerow_man[7:0]
0x392F	PWM_CTRL_2F	0x40	RW	Bit[7]: r_strobe_frm_pwen Bit[6]: r_strobe_frm_pwst Bit[5]: r_strobe_pol Bit[4]: r_strobe_step_pix Bit[3]: r_step_onerow_precision_man Bit[2:0]: r_strobe_st_opt

4.8 low power modes

The OV9281 sensor supports three low power modes:

- low frame rate streaming mode
- external trigger snapshot mode

table 4-11 low power mode control registers

register	description
0x4F00	Power Control Options 0x00: normal mode 0x01: low power mode
0x3030	Low Power Mode Control Bit[4]: Low frame rate streaming mode (i.e., repeating the sequence of streaming {0x303F} frames and then sleeping {0x302C, 0x302F} lines) Bit[2]: External trigger snapshot mode A rising edge on FSIN pin wakes the sensor up and streams out {0x303F} frames Others: For debug only
0x303F	number of active frames
{0x302C, 0x302F}	number of lines of sleep period
0x3023	Bit[1]: MIPI power down enable during sleep period 0: disable for low power streaming mode

4.8.1 low frame rate mode

In low frame rate mode, the OV9281 sensor streams N frames, idles for M frames, and then repeats. The power consumption of the OV9281 sensor is close to $N/(N+M)$ of the current in full speed streaming mode but the maximum integration time is limited to about $t_{Frame} - 40t_{Row}$.

figure 4-6 low frame rate mode timing

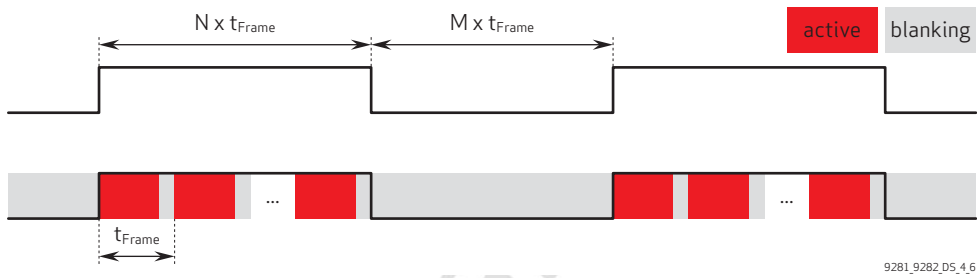

4.8.2 snapshot mode

In snapshot mode, the OV9281 streams N frames upon request through the SCCB and then stays idle until the next request (see figure 4-7).

figure 4-7 snapshot mode timing

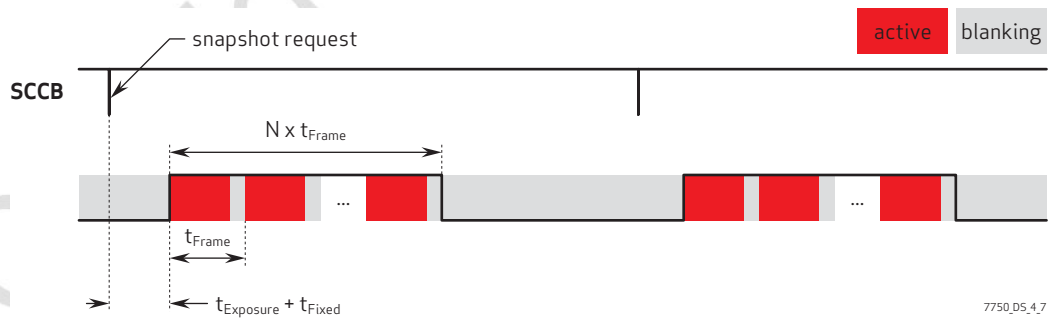

4.8.3 external trigger snapshot mode

Upon the rising edge of FSIN pulse, the sensor wakes up from sleep mode, starts integration, reads out and sends out number (set by register 0x303F) of frames. The sensor then returns back to sleep mode (see **figure 4-8**).

figure 4-8 external snapshot mode timing

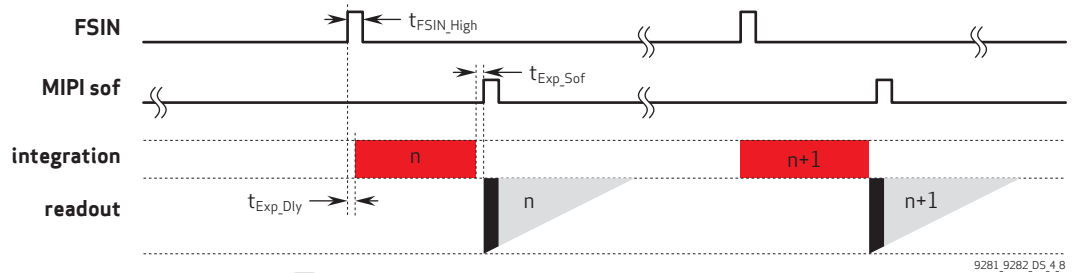

9281_9282_DS_4_8

FSIN pulse width, t_{FSIN_High} , should be no shorter than 5 input clock cycles. The wake up sequence takes 61396 input clock cycles, and then the pixel array is reset. The integration starts when the pixel reset finish, the interval from FSIN rising to integration, t_{Exp_Dly} , equals to $61396 \times t_{XVCLK} + n \times t_{Row}$, where n (≤ 10) is programmable. The frame start short packet is sent out about 10 row periods after integration finish.

The reference voltage of VN2 is critical for image quality in this mode. It is recommended to have a $1\mu F$ cap on this pin to keep the voltage after the sensor goes to sleep mode between two adjacent triggers in a burst. If the sleep period is too long between bursts (e.g., more than 100ms), please discard the first triggered frame (e.g., the frame triggered by the red pulse) as shown in **figure 4-9**. The second frame can be triggered as early as the first frame finishes. It is recommended to keep the frame rate within the burst no less than 10 fps to prevent VN2 discharging too much.

figure 4-9 frame triggered by red pulse diagram

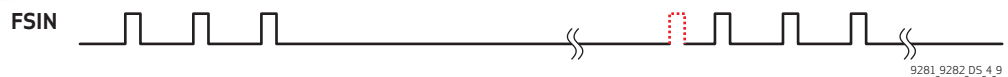

9281_9282_DS_4_9

5 image sensor processor digital functions

5.1 ISP general controls

table 5-1 ISP top registers

address	register name	default value	R/W	description
0x5000	ISP CTRL00	0x9F	RW	Bit[7:6]: isp_sof_sel Bit[5]: isp_eof_sel Bit[4]: bc_en Bit[3]: wc_en Bit[2]: dpc_buf_en Bit[1]: awbg_en Bit[0]: blc_en
0x5001	ISP CTRL 01	0x00	RW	Bit[7]: dgc_en Bit[6:5]: Reserved Bit[4]: latch_en Bit[3]: r_size_man Bit[2]: r_pre_isp_raw_en Bit[1]: bypass_isp1 Bit[0]: bypass_isp0

5.2 manual white balance (MWB)

The MWB provides digital gain for R, G, and B channels. Each channel gain is 12-bit. 0x400 is 1x gain.

table 5-2 manual AWB_gain registers

address	register name	default value	R/W	description
0x3400	AWB RED GAIN	0x04	RW	Bit[3:0]: AWB red gain[11:8]
0x3401	AWB RED GAIN	0x00	RW	Bit[7:0]: AWB red gain[7:0]
0x3402	AWB GRN GAIN	0x04	RW	Bit[3:0]: AWB green gain[11:8]
0x3403	AWB GRN GAIN	0x00	RW	Bit[7:0]: AWB green gain[7:0]
0x3404	AWB BLU GAIN	0x04	RW	Bit[3:0]: AWB blue gain[11:8]
0x3405	AWB BLU GAIN	0x00	RW	Bit[7:0]: AWB blue gain[7:0]
0x3406	AWB MAN CTRL	0x01	RW	Bit[0]: AWB manual control

5.3 manual exposure and gain control

table 5-3 manual exposure and gain control registers

address	register name	default value	R/W	description
0x3500	AEC EXPO	0x00	RW	Bit[3:0]: Long exposure[19:16]
0x3501	AEC EXPO	0x02	RW	Bit[7:0]: Long exposure[15:8]
0x3502	AEC EXPO	0x00	RW	Bit[7:0]: Long exposure[3:0] Low 4 bits are fraction bits
0x3503	MANUAL CONTROL	0x00	RW	Bit[1]: Gain manual enable Bit[0]: Exposure manual enable
0x350A	DIG GAIN	0x04	RW	Bit[7:0]: Long digital gain[13:6]
0x350B	DIG GAIN	0x00	RW	Bit[5:0]: Long digital gain[5:0]

6 system control

System control registers include clock, reset control, and PLL configuration. Individual modules can be reset or clock gated by setting the appropriate registers. For system control registers, see [table 7-2](#).

6.1 mobile industry processor interface (MIPI)

The OV9281 MIPI interface supports a single uni-directional clock lane and a single uni-directional data lane. The data lane has full support for high speed (HS) data transfer. Contact your local OmniVision FAE for more details.

table 6-1 MIPI top control registers (sheet 1 of 7)

address	register name	default value	R/W	description
0x4800	MIPI_CTRL_00	0x04	RW	Bit[7:6]: Reserved Bit[5]: gate_sc_en 0: Clock lane is free running 1: Gate clock lane when there is no packet to transmit Bit[4]: line_sync_en 0: Do not send line short packet for each line 1: Send line short packet for each line Bit[2]: pclk_inv_o 0: Use rising edge of mipi_pclk_o to generate MIPI bus to PHY 1: Use falling edge of mipi_pclk_o to generate MIPI bus to PHY Bit[1]: firt_bit Change clk_lane first bit 0: Output 8'h55 1: Output 8'hAA Bit[0]: LPX_select for pclk domain 0: Auto calculate t_lpx_p, unit: pclk2x cycle 1: Use lpx_p_min[7:0]

table 6-1 MIPI top control registers (sheet 2 of 7)

address	register name	default value	R/W	description
0x4802	MIPI CTRL 02	0x00	RW	Bit[7]: hs_prepare_sel 0: Auto calculate T_hs_prepare, unit: pclk2x 1: Use hs_prepare_min_o[7:0] Bit[6]: clk_prepare_sel 0: Auto calculate T_clk_prepare, unit: pclk2x 1: Use clk_prepare_min_o[7:0] Bit[5]: clk_post_sel 0: Auto calculate T_clk_post, unit: pclk2x 1: Use clk_post_min_o[7:0] Bit[4]: clk_trail_sel 0: Auto calculate T_clk_trail, unit: pclk2x 1: Use clk_trail_min_o[7:0] Bit[3]: hs_exit_sel 0: Auto calculate T_hs_exit, unit: pclk2x 1: Use hs_exit_min_o[7:0] Bit[2]: hs_zero_sel 0: Auto calculate T_hs_zero, unit: pclk2x 1: Use hs_zero_min_o[7:0] Bit[1]: hs_trail_sel 0: Auto calculate T_hs_trail, unit: pclk2x 1: Use hs_trail_min_o[7:0] Bit[0]: clk_zero_sel 0: Auto calculate T_clk_zero, unit: pclk2x 1: Use clk_zero_min_o[7:0]
0x4803	MIPI CTRL 03	0x10	RW	Bit[7:5]: Reserved Bit[4]: pu_mark_en_o Bit[3]: manu_offset_o t_perio manual offset SMIA Bit[2]: r_manual_half2one t_period half to 1 SMIA Bit[1:0]: Reserved
0x4805	MIPI CTRL 05	0x00	RW	Bit[7:4]: Reserved Bit[3]: lpda_retim_manu_o Bit[2]: lpda_retim_sel 1: Manual Bit[1]: lpck_retim_manu_o Bit[0]: lpck_retim_sel 1: Manual

table 6-1 MIPI top control registers (sheet 3 of 7)

address	register name	default value	R/W	description
0x4806	MIPI CTRL 06	0x00	RW	Bit[7:5]: Reserved Bit[4]: pu_mark_en_o Power up mark1 enable test mode Bit[3]: mipi_remot_rst Bit[2]: mipi_susp Bit[1]: mipi_ul_auto_en Bit[0]: tx_lsb_first 0: High bit first 1: Low power transmit low bit first
0x4807	MIPI CTRL 07	0x03	RW	Bit[7:4]: Reserved Bit[3:0]: sw_t_lpx ul_tx T_lpx
0x4808	MIPI CTRL 08	0x18	RW	Bit[7:0]: wkup_dly Mark1 wakeup delay/2^10
0x4810	MIPI_FCNT_MAX	0xFF	RW	High Byte of Maximum Frame Count of Frame Sync Short Packet
0x4811	MIPI_FCNT_MAX	0xFF	RW	Low Byte of Maximum Frame Count of Frame Sync Short Packet
0x4813	MIPI CTRL13	0x00	RW	Bit[7:3]: Reserved Bit[2]: vc_sel VC or reg VC Bit[1:0]: VC Virtual channel of MIPI
0x4814	MIPI CTRL14	0x2A	RW	Bit[7]: Reserved Bit[6]: lpkt_dt_sel 0: Use mipi_dt 1: Use dt_man_o as long packet data Bit[5:0]: dt_man Manual data type
0x4818	MIPI_HS_ZERO_MIN	0x00	RW	Bit[7:2]: Reserved Bit[1:0]: hs_zero_min[9:8] High byte of minimum value of hs_zero, unit: ns
0x4819	MIPI_HS_ZERO_MIN	0x70	RW	Bit[7:0]: hs_zero_min[7:0] Low byte of minimum value of hs_zero hs_zero_real = hs_zero_min_o + Tui*ui_hs_zero_min_o
0x481A	MIPI_HS_TRAIL_MIN	0x00	RW	Bit[7:2]: Reserved Bit[1:0]: hs_trail_min[9:8] High byte of minimum value of hs_trail, unit: ns

table 6-1 MIPI top control registers (sheet 4 of 7)

address	register name	default value	R/W	description
0x481B	MIPI_HS_TRAIL_MIN	0x3C	RW	Bit[7:0]: hs_trail_min[7:0] Low byte of minimum value for hs_trail, unit: ns hs_trail_real = hs_trail_min_o + Tui*ui_hs_trail_min_o
0x481C	MIPI_CLK_ZERO_MIN	0x01	RW	Bit[7:2]: Reserved Bit[1:0]: clk_zero_min[9:8] High byte of minimum value for clk_zero, unit: ns
0x481D	MIPI_CLK_ZERO_MIN	0x2C	RW	Bit[7:0]: clk_zero_min[7:0] Low byte of minimum value for clk_zero, unit: ns clk_zero_real = clk_zero_min_o + Tui*ui_clk_zero_min_o
0x481E	MIPI_CLK_PREPARE_MAX	0x5F	RW	Bit[7:0]: clk_prepare_max Maximum value for clk_prepare, unit: ns
0x481F	MIPI_CLK_PREPARE_MIN	0x26	RW	Bit[7:0]: clk_prepare_min Minimum value for clk_prepare, unit: ns
0x4820	MIPI_CLK_POST_MIN	0x00	RW	Bit[7:2]: Reserved Bit[1:0]: clk_post_min[9:8] High byte of minimum value for clk_post, unit: ns
0x4821	MIPI_CLK_POST_MIN	0x3C	RW	Bit[7:0]: clk_post_min[7:0] Low byte of minimum value for clk_post, unit: ns clk_post_real = clk_post_min_o + Tui*ui_clk_post_min_o
0x4822	MIPI_CLK_TRAIL_MIN	0x00	RW	Bit[7:2]: Reserved Bit[1:0]: clk_trail_min[9:8] High byte of minimum value for clk_trail, unit: ns
0x4823	MIPI_CLK_TRAIL_MIN	0x3C	RW	Bit[7:0]: clk_trail_min[7:0] Low byte of minimum value for clk_trail, unit: ns clk_trail_real = clk_trail_min_o + Tui*ui_clk_trail_min_o
0x4824	MIPI_LPX_P_MIN	0x00	RW	Bit[7:2]: Reserved Bit[1:0]: lpx_p_min[9:8] High byte of minimum value for lpx_p, unit: ns

table 6-1 MIPI top control registers (sheet 5 of 7)

address	register name	default value	R/W	description
0x4825	MIPI_LPX_P_MIN	0x32	RW	Bit[7:0]: lpx_p_min[7:0] Low byte of minimum value for lpx_p, unit: ns $lpx_p_real = lpx_p_min_o + Tui * ui_lpx_p_min_o$
0x4826	MIPI_HS_PREPARE_MIN	0x32	RW	Bit[7:0]: hs_prepare_min Minimum value of hs_prepare, unit: ns
0x4827	MIPI_HS_PREPARE_MAX	0x55	RW	Bit[7:0]: hs_prepare_max Maximum value for hs_prepare, unit: ns
0x4828	MIPI_HS_EXIT_MIN	0x00	RW	Bit[7:2]: Reserved Bit[1:0]: hs_exit_min[9:8] High byte of minimum value for hs_exit, unit: ns
0x4829	MIPI_HS_EXIT_MIN	0x64	RW	Bit[7:0]: hs_exit_min[7:0] Low byte of minimum value for hs_exit, unit: ns $hs_exit_real = hs_exit_min_o + Tui * ui_hs_exit_min_o$
0x482A	MIPI_UI_HS_ZERO_MIN	0x06	RW	Minimum UI Value of hs_zero, unit: UI
0x482B	MIPI_UI_HS_TRAIL_MIN	0x04	RW	Minimum UI Value of hs_trail, unit: UI
0x482C	MIPI_UI_CLK_ZERO_MIN	0x00	RW	Minimum UI Value of clk_zero, unit: UI
0x482D	MIPI_UI_CLK_PREPARE_MIN	0x00	RW	Minimum UI Value of clk_prepare, unit: UI
0x482E	MIPI_UI_CLK_POST_MIN	0x34	RW	Minimum UI Value of clk_post, unit: UI
0x482F	MIPI_UI_CLK_TRAIL_MIN	0x00	RW	Minimum UI Value of clk_trail, unit: UI
0x4830	MIPI_UI_LPX_P_MIN	0x00	RW	Minimum UI Value of lpx_p (pclk2x domain), unit: UI
0x4831	MIPI_UI_HS_PREPARE	0x64	RW	Bit[7:4]: ui_hs_prepare_max Maximum UI value of hs_prepare, unit: UI Bit[3:0]: ui_hs_prepare_min Minimum UI value of hs_prepare, unit: UI
0x4832	MIPI_UI_HS_EXIT_MIN	0x00	RW	Minimum UI Value of hs_exit, unit: UI
0x4833	MIPI_PKT_START_SIZE	0x06	RW	Bit[7:6]: Reserved Bit[5:0]: mipi_pkt_start_size[5:0]

table 6-1 MIPI top control registers (sheet 6 of 7)

address	register name	default value	R/W	description
0x4837	MIPI_PCLK_PERIOD	0x10	RW	Period of Pclk2x, pclk_div = 1, and 1-bit Decimal
0x4838	MIPI_LP_GPIO0	0x00	RW	Bit[7]: lp_sel0 0: Auto generate mipi_lp_dir0_o 1: Use lp_dir_man0 to be mipi_lp_dir0_o Bit[6]: lp_dir_man0 0: Input 1: Output Bit[5]: lp_p0_o Bit[4]: lp_n0_o Bit[3]: lp_sel1 0: Auto generate mipi_lp_dir1_o 1: Use lp_dir_man1 to be mipi_lp_dir1_o Bit[2]: lp_dir_man1 0: Input 1: Output Bit[1]: lp_p1_o Bit[0]: lp_n1_o
0x4839	MIPI_LP_GPIO1	0x00	RW	Bit[7]: lp_sel2 0: Auto generate mipi_lp_dir2_o 1: Use lp_dir_man2 to be mipi_lp_dir2_o Bit[6]: lp_dir_man2 0: Input 1: Output Bit[5]: lp_p2_o Bit[4]: lp_n2_o Bit[3]: lp_sel3 0: Auto generate mipi_lp_dir3_o 1: Use lp_dir_man3 to be mipi_lp_dir3_o Bit[2]: lp_dir_man3 0: Input 1: Output Bit[1]: lp_p3_o Bit[0]: lp_n3_o
0x483C	MIPI_CTRL33	0x02	RW	Bit[7:4]: Reserved Bit[3:0]: t_clk_pre Unit: pclk2x cycle

table 6-1 MIPI top control registers (sheet 7 of 7)

address	register name	default value	R/W	description
0x483D	MIPI_LP_GPIO4	0x00	RW	Bit[7]: lp_ck_sel0 0: Auto generate mipi_ck_lp_dir0_o 1: Use lp_ck_dir_man0 to be mipi_ck_lp_dir0_o Bit[6]: lp_dir_man0 0: Input 1: Output Bit[5]: lp_ck_p0_o Bit[4]: lp_ck_n0_o Bit[3]: lp_ck_sel1 0: Auto generate mipi_ck_lp_dir1_o 1: Use lp_ck_dir_man1 to be mipi_ck_lp_dir1_o Bit[2]: lp_ck_dir_man1 0: Input 1: Output Bit[1]: lp_ck_p1_o Bit[0]: lp_ck_n1_o
0x484A	MIPI_CTRL4A	0x3F	RW	Bit[7:6]: Reserved Bit[5]: slp_lp_pon_man_o Set for power up Bit[4]: slp_lp_pon_da Bit[3]: slp_lp_pon_ck Bit[2]: mipi_slp_man_st MIPI bus status manual control enable in sleep mode Bit[1]: clk_lane_state Bit[0]: data_lane_state
0x484B	MIPI_CTRL4B	0x07	RW	Bit[7:2]: Reserved Bit[1]: clk_start_sel_o 0: Clock starts after SOF 1: Clock starts after reset Bit[0]: sof_sel_o 0: Frame starts after HREF occurs 1: Frame starts after SOF
0x484C	MIPI_CTRL4C	0x00	RW	Bit[7:4]: Reserved Bit[3]: SMIA fcnt_i select Bit[2]: PRBS enable Bit[1]: hs_test_only MIPI high speed only test mode enable Bit[0]: Set frame count to inactive mode (keep 0)
0x484D	TEST_PATTEN_DATA	0xB6	RW	Data Lane Test Pattern Register
0x484E	FE_DLY	0x10	RW	Last Packet to Frame End Delay / 2
0x484F	TEST_PATTEN_CK_DATA	0x55	RW	clk_test_patten_reg

6.2 digital video port (DVP)

The DVP provides 10-bit parallel data output.

table 6-2 DVP control registers (sheet 1 of 2)

address	register name	default value	R/W	description
0x4701	VSYNCOUT_SEL	0x00	RW	Bit[7:2]: Reserved Bit[1:0]: VSYNC output select 00: eof_o 01: Output gpo_vsync 10: Output hsync_o 11: eof_o
0x4702	VSYNC_RISE_LNT	0x00	RW	Bit[7:0]: vsync_rise_Int[15:8] Line counter that controls rising position of VSYNC
0x4703	VSYNC_RISE_LNT	0x02	RW	Bit[7:0]: vsync_rise_Int[7:0] Line counter that controls rising position of VSYNC
0x4704	VSYNC_FALL_LNT	0x00	RW	Bit[7:0]: vsync_fall_Int[15:8] Line counter that controls falling position of VSYNC
0x4705	VSYNC_FALL_LNT	0x06	RW	Bit[7:0]: vsync_fall_Int[7:0] Line counter that controls falling position of VSYNC
0x4706	VSYNC_CHG_PCNT	0x00	RW	Bit[7:0]: vsync_chg_pcnt[15:8] VSYNC change position indicated by pixel position
0x4707	VSYNC_CHG_PCNT	0x10	RW	Bit[7:0]: vsync_chg_pcnt[7:0] VSYNC change position indicated by pixel position
0x4708	POLARITY_CTRL	0x09	RW	Bit[7]: Clock DDR mode enable Bit[6]: hts_man_en Bit[5]: VSYNC gate enable Bit[4]: HREF gate enable Bit[3]: r_fo_nofrst Bit[2]: HREF polarity Bit[1]: VSYNC polarity Bit[0]: PCLK polarity
0x4709	BIT_TEST_ORDER	0x00	RW	Bit[7]: Reserved Bit[6:4]: Data bit swap Bit[3:0]: Reserved
0x470C	R_READ_CTRL	0x81	RW	Bit[7:2]: Reserved Bit[1]: first_lv_sel Bit[0]: r_lpcnt_free

table 6-2 DVP control registers (sheet 2 of 2)

address	register name	default value	R/W	description
0x470F	BYP_SEL	0x00	RW	Bit[7:5]: Reserved Bit[4]: href_sel Bit[3:0]: bypass_sel

Confidential for
honeywell-suzhou

OV9281

b&w CMOS 1 megapixel (1280 x 800) image sensor with OmniPixel3-GS™ technology

Confidential for
honeywell-suzhou

7 register tables

The following tables provide descriptions of the device control registers contained in the OV9281. For all register enable/disable bits, ENABLE = 1 and DISABLE = 0. The device slave addresses are 0xC0 for write and 0xC1 for read.

7.1 system control [0x0100 - 0x010A, 0x3000 - 0x301F - 0x303F]

table 7-1 system control registers (sheet 1 of 8)

address	register name	default value	R/W	description
0x0100	SC_MODE_SELECT	0x00	RW	Bit[7:1]: Not used Bit[0]: Mode select 0: software_standby 1: Streaming
0x0101~ 0x0102	RSVD	–	–	Reserved
0x0103	SC_SOFTWARE_RESET	0x00	RW	Bit[7:1]: Not used Bit[0]: software_reset 0: Off 1: On
0x0104~ 0x0105	RSVD	–	–	Reserved
0x0106	SC_FAST_STANDBY_CTRL	0x01	RW	Bit[7:1]: Not used Bit[0]: fast_standby 0: Frame completes before mode entry 1: Frame may be truncated before mode entry
0x0107	CCI ADDRESS CONTROL 20	0x20	RW	CCI Slave 20
0x0108	CCI ADDRESS CONTROL 6C	0x6C	RW	CCI Slave 6C
0x0109	CCI ADDRESS CONTROL C0	0xC0	RW	CCI Slave C0
0x010A	CCI ADDRESS CONTROL 7C	0x7C	RW	CCI Slave 7C
0x3000	RSVD	–	–	Reserved
0x3001	SC_CTRL_01	0x02	RW	Bit[7:6]: pd_data_en Bit[5:0]: pd_pk
0x3002~ 0x3003	RSVD	–	–	Reserved

table 7-1 system control registers (sheet 2 of 8)

address	register name	default value	R/W	description
0x3004	SC_CTRL_04	0x00	RW	Bit[7:2]: Reserved Bit[1:0]: io_pad_out_en[17:16]
0x3005	SC_CTRL_05	0x00	RW	Bit[7:0]: io_pad_out_en[15:8]
0x3006	SC_CTRL_06	0x00	RW	Bit[7:0]: io_pad_out_en[7:0]
0x3007	SC_CTRL_07	0x00	RW	Bit[7:2]: Reserved Bit[1:0]: io_pad_out[17:16]
0x3008	SC_CTRL_08	0x00	RW	Bit[7:0]: io_pad_out[15:8]
0x3009	SC_CTRL_09	0x00	RW	Bit[7:0]: io_pad_out[7:0]
0x300A	SC_CHIP_ID_HIGH	0x92	R	Chip ID High Byte
0x300B	SC_CHIP_ID_LOW	0x81	R	Chip ID Low Byte
0x300C	SC_CTRL_0C	–	R	Revision ID
0x300D	SC_CTRL_0D	0x00	RW	Bit[7]: gclk_emblin Bit[6]: gclk_dpcm Bit[5]: gclk_testmode Bit[4]: gclk_smia Bit[3]: gclk_otp Bit[2]: Reserved Bit[1]: gclk_mipi Bit[0]: gclk_dvp
0x300E	SC_CTRL_0E	0x00	RW	Bit[7]: gclk_vfifo Bit[6]: Reserved Bit[5]: gclk_isp Bit[4]: gclk_blc Bit[3]: Reserved Bit[2]: gclk_aec Bit[1]: gclk_stb Bit[0]: gclk_fc
0x300F	SC_CTRL_0F	0xF0	RW	Bit[7]: Reserved Bit[6]: daclk_gs_en Bit[5:0]: Reserved
0x3010	SC_CTRL_10	0xC1	RW	Bit[7]: scale_div_man_en Bit[6]: daclk_en Bit[5:4]: daclk_sel 00: /1 01: /2 10: /4 11: /1 Bit[3]: Reserved Bit[2:0]: pll_scale_div

table 7-1 system control registers (sheet 3 of 8)

address	register name	default value	R/W	description
0x3011	SC_CTRL_11	0x08	RW	Bit[7]: hstx_open_term Bit[6:5]: d1_skew Bit[4]: pllclk_out_enable Bit[3]: mipi_pad Bit[2:0]: pgm_vcm High speed common mode voltage
0x3012	SC_MIPI_PHY0	0x70	RW	Bit[7:4]: sel_drv Bit[3:2]: ck_skew Bit[1:0]: d0_skew
0x3013	SC_MIPI_PHY1	0x10	RW	Bit[7]: lp_sr Bit[6]: pgm_bp_hs_en_lat Bit[5:4]: pgm_lptx Driving strength control of low speed transmitter Bit[3:2]: r_iref Bit[1:0]: bitssel
0x3014	SC_MIPI_SC_CTRL0	0x04	RW	Bit[7:6]: mipi_ck_skew_o Bit[5]: mipi_phy_rst_o Bit[4]: r_phy_pd_mipi 1: Power down PHY HS TX Bit[3]: r_phy_pd_lprx 1: Power down PHY LP RX module Bit[2]: mipi_en 0: DVP enable 1: MIPI enable Bit[1]: mipi_susp_reg MIPI system suspend register 1: Suspend Bit[0]: lane_dis_op 0: Use mipi_release1/2 and lane_disable1/2 to disable two data lanes 1: Use lane_disable1/2 to disable two data lanes
0x3015	SC_MIPI_SC_CTRL1	0x10	RW	Bit[7:0]: MIPI ULPS resume mark1 detect length
0x3016	SC_CLKRST0	0xF0	RW	Bit[7]: sclk_fc Bit[6]: sclk_stb Bit[5]: sclk_aec Bit[4]: sclk_tc Bit[3]: rst_fc Bit[2]: rst_stb Bit[1]: rst_aec Bit[0]: rst_tc

table 7-1 system control registers (sheet 4 of 8)

address	register name	default value	R/W	description
0x3017	SC_CLKRST1	0xF0	RW	Bit[7]: sclk_blc Bit[6]: sclk_isp Bit[5]: sclk_psv_ctrl Bit[4]: sclk_vfifo Bit[3]: rst_blc Bit[2]: rst_isp Bit[1]: rst_psv_ctrl Bit[0]: rst_vfifo
0x3018	SC_CLKRST2	0xF0	RW	Bit[7]: pclk_dvp Bit[6]: sclk_mipi Bit[5]: sclk_ac Bit[4]: sclk_otp Bit[3]: rst_dvp Bit[2]: rst_mipi Bit[1]: rst_ac Bit[0]: rst_otp
0x3019	SC_CLKRST3	0xF0	RW	Bit[7]: sclk_smia Bit[6]: sclk_testmode Bit[5]: sclk_dpcm Bit[4]: sclk_emblne Bit[3]: rst_smia Bit[2]: rst_testmode Bit[1]: rst_dpcm Bit[0]: rst_emblne
0x301A	SC_CLKRST4	0xF0	RW	Bit[7]: sdclk_sd Bit[6]: padclk_mipi_sc Bit[5]: pclk_vfifo Bit[4]: pclk_mipi Bit[3]: rst_sd Bit[2]: rst_mipi_s Bit[1]: rst_ulpm Bit[0]: rst_srb
0x301B	SC_CLKRST5	0xF0	RW	Bit[7]: sclk_src Bit[6]: sclk_cvdn Bit[5]: sclk_asram_tst Bit[4]: sclk_snr_sync Bit[3]: rst_src Bit[2]: rst_cvdn Bit[1]: rst_asram_tst Bit[0]: rst_snr_sync

table 7-1 system control registers (sheet 5 of 8)

address	register name	default value	R/W	description
0x301C	SC_CLKRST6	0xF2	RW	Bit[7]: sclk_bist Bit[6]: sclk_srb Bit[5]: sclk_grp Bit[4]: sclk_ulpm Bit[3]: rst_bist Bit[2]: rst_srb Bit[1]: rst_grp Bit[0]: rst_ulpm
0x301D	SC_FREX_RST	0x00	RW	Bit[7]: frex_mask_aec Bit[6]: frex_mask_blc Bit[5]: frex_mask_isp Bit[4]: frex_mask_dvp Bit[3]: frex_mask_mipi Bit[2]: frex_mask_vfifo Bit[1]: Reserved Bit[0]: frex_mask_mipi_phy
0x301E	SC_CTRL_1E	0x03	RW	Bit[7:5]: sdiv Divider for sigma delta (sdclk) Bit[4]: Reserved Bit[3]: pclk_sel 0: pll_pclk 1: pll_pclk_d2 Bit[2:1]: Reserved Bit[0]: sclk2x_source_sel 0: pll_sclk 1: pll_sclk_d2
0x301F	SC_CLOCK_SEL	0x03	RW	Bit[7:6]: mipi_data_skew_o Bit[5]: mipi_clk_lane_ctrl 0: Clock lane hold LP00 when pd_mipi 1: Clock lane is high-z when pd_mipi Bit[4]: mipi_ctr_en 0: Disable the function 1: Enable MIPI remote reset and suspend control sc Bit[3]: mipi_rst_sel 0: MIPI remote reset all registers 1: MIPI remote reset all digital module Bit[2]: gpio_pclk_en Bit[1]: frex_ef_sel Bit[0]: cen_global_o

table 7-1 system control registers (sheet 6 of 8)

address	register name	default value	R/W	description
0x3020	SC_CTRL_20	0x00	RW	Bit[7]: gclk_pwm Bit[6]: gclk_fmt Bit[5]: gclk_strobe Bit[4]: Reserved Bit[3]: gclk_ulpm Bit[2]: Reserved Bit[1]: gclk_srb Bit[0]: gclk_bist
0x3021	SC_CTRL_21	0x00	RW	Bit[7]: gclk_sync Bit[6]: gclk_asram_tst Bit[5]: gclk_cvdn Bit[4]: gclk_src Bit[3]: gclk_mipi Bit[2]: gclk_vfifo Bit[1:0]: Reserved
0x3022	SC_MISC_CTRL	0x01	RW	Bit[7:4]: mipi_bit_sel 0100: 8-bit mode 0101: 10-bit mode 0110: 12-bit mode Others: Reserved Bit[3]: mipi_lvds_mode_o Bit[2]: Clock lane disable 1 Bit[1]: Clock lane disable 2 Bit[0]: pd_mipi_rst_sync pd_mipi enable when rst_sync
0x3023	SC_CTRL_23	0x07	RW	Bit[7]: Reserved Bit[6]: phy_pd_mipi_pwdn_dis Bit[5]: phy_pd_lrp_x_pwdn_dis Bit[4]: r_stb_rst_dis_o 0: Reset all blocks in software standby mode 1: TC, sensor_control, ISP are reset, others are not Bit[3]: pd_ana_dis Bit[2]: Reserved Bit[1]: phy_pd_mipi_slppd_dis Bit[0]: phy_pd_lpr_x_slppd_dis
0x3024	SC_CTRL_24	0x00	RW	Bit[7:1]: Reserved Bit[0]: pd_mipi_auto
0x3025	SC_GP_IO_SEL0	0x00	RW	Bit[7:2]: Reserved Bit[1:0]: io_pad_sel_o[17:16]
0x3026	SC_GP_IO_SEL1	0x00	RW	Bit[7:0]: io_pad_sel_o[15:8]
0x3027	SC_GP_IO_SEL2	0x00	RW	Bit[7:0]: io_pad_sel_o[7:0]
0x3028	SC_GP_IO_IN0	–	R	Bit[7:0]: io_pad_i[23:16]

table 7-1 system control registers (sheet 7 of 8)

address	register name	default value	R/W	description
0x3029	SC_GP_IO_IN1	–	R	Bit[7:0]: io_pad_i[15:8]
0x302A	SC_GP_IO_IN2	–	R	Bit[7:0]: io_pad_i[7:0]
0x302B	SC_CTRL_2B	0xE0	RW	Bit[7:0]: sccb_id[7:0]
0x302C	SC_LP_CTRL0	0x01	RW	Bit[7:0]: r_sleep_period[31:24]
0x302D	SC_LP_CTRL1	0x00	RW	Bit[7:0]: r_sleep_period[23:16]
0x302E	SC_LP_CTRL2	0x00	RW	Bit[7:0]: r_sleep_period[15:8]
0x302F	SC_LP_CTRL3	0x00	RW	Bit[7:0]: r_sleep_period[7:0]
0x3030	SC_LP_CTRL4	0x10	RW	Bit[7]: r_auto_sleep_en Bit[6]: r_gpio_sel 1: Sleep can be read by GPIO (Y9) Bit[5]: r_wake_up_pol Bit[4]: r_aslp_repeat Bit[3]: r_als_wake_up_en Bit[2]: r_fsin_wake_up_en Bit[1:0]: Reserved
0x3031	IO_Y_OEN_SLEEP0	0x03	RW	Bit[7:2]: Reserved Bit[1:0]: io_y_oen_sleep[17:16]
0x3032	IO_Y_OEN_SLEEP1	0xFF	RW	Bit[7:0]: io_y_oen_sleep[15:8]
0x3033	IO_Y_OEN_SLEEP2	0xFF	RW	Bit[7:0]: io_y_oen_sleep[7:0]
0x3034	IO_Y_OEN_PWDN0	0x03	RW	Bit[7:2]: Reserved Bit[1:0]: io_y_oen_pwdn[17:16]
0x3035	IO_Y_OEN_PWDN1	0xFF	RW	Bit[7:0]: io_y_oen_pwdn[15:8]
0x3036	IO_Y_OEN_PWDN2	0xFF	RW	Bit[7:0]: io_y_oen_pwdn[7:0]
0x3037	SC_CTRL_37	0xF0	RW	Bit[7]: Reserved Bit[6]: sclk_strobe Bit[5]: sclk_fmt Bit[4]: sclk_pwm Bit[3]: rst_grp Bit[2]: rst_strobe Bit[1]: rst_fmt Bit[0]: rst_pwm
0x3038	SC_CTRL_38	0x58	RW	Bit[7:5]: Reserved Bit[4]: padclk_ulpm Bit[3]: Reserved Bit[2]: frex_mask_strobe Bit[1]: frex_mask_fmt Bit[0]: frex_mask_pwm

table 7-1 system control registers (sheet 8 of 8)

address	register name	default value	R/W	description
0x3039	SC_CTRL_39	0x32	RW	Bit[7:5]: mipi_lane_num 000: One-lane mode 001: Two-lane mode Bit[4]: mipi_en 0: DVP enable 1: MIPI enable Bit[3:2]: r_phy_pd_mipi Bit[1]: phy_rst option 1: Reset PHY when rst_sync Bit[0]: lane_dis_option 1: Disable lanes when pd_mipi
0x303A	SC_CTRL_3A	0x00	RW	Bit[7:0]: MIPI lane disable
0x303B	SC_CTRL_3B	0x00	RW	Bit[7:2]: Reserved Bit[1]: sccb_pgm_id_en Bit[0]: sccb_id2_nack_en
0x303C	SC_CTRL_3C	0x00	RW	Bit[7:4]: Reserved Bit[3:0]: r_ppump_div
0x303D	SC_CTRL_3D	0x02	RW	Bit[7:4]: r_npump2_div Bit[3:0]: r_npump1_div
0x303E	SC_CTRL_3E	0x07	RW	Bit[7:6]: Reserved Bit[5:0]: r_pump_ctrl
0x303F	SC_CTRL_3F	0x03	RW	Bit[7:0]: r_frame_on_num

7.2 PLL control [0x0300 - 0x0319]

table 7-2 PLL control registers (sheet 1 of 3)

address	register name	default value	R/W	description
0x0300	PLL_CTRL_00	0x01	RW	Bit[7:3]: Reserved Bit[2:0]: pll1_prediv
0x0301	PLL_CTRL_01	0x00	RW	Bit[7:2]: Reserved Bit[1:0]: pll1_divp_h
0x0302	PLL_CTRL_02	0x32	RW	Bit[7:0]: pll1_divp_l
0x0303	PLL_CTRL_03	0x00	RW	Bit[7:4]: Reserved Bit[3:0]: pll1_divm
0x0304	PLL_CTRL_04	0x03	RW	Bit[7:2]: Reserved Bit[1:0]: pll1_div_mipi

table 7-2 PLL control registers (sheet 2 of 3)

address	register name	default value	R/W	description
0x0305	PLL_CTRL_05	0x02	RW	Bit[7:2]: Reserved Bit[1:0]: pll1_divsp
0x0306	PLL_CTRL_06	0x01	RW	Bit[7:1]: Reserved Bit[0]: pll1_divs
0x0307	PLL_CTRL_07	0x00	RW	Bit[7:1]: Reserved Bit[0]: pll1_div_rst_sync
0x0308	PLL_CTRL_08	0x00	RW	Bit[7:1]: Reserved Bit[0]: pll1_bypass
0x0309	PLL_CTRL_09	0x01	RW	Bit[7:1]: Reserved Bit[2:0]: pll1_cp
0x030A	PLL_CTRL_0A	0x00	RW	Bit[7:1]: Reserved Bit[0]: pll1_predivp
0x030B	PLL_CTRL_0B	0x04	RW	Bit[7:3]: Reserved Bit[2:0]: pll2_prediv
0x030C	PLL_CTRL_0C	0x00	RW	Bit[7:2]: Reserved Bit[1:0]: pll2_divp_h
0x030D	PLL_CTRL_0D	0x50	RW	Bit[7:0]: pll2_divp_l
0x030E	PLL_CTRL_0E	0x02	RW	Bit[7:3]: Reserved Bit[2:0]: pll2_divs
0x030F	PLL_CTRL_0F	0x03	RW	Bit[7:4]: Reserved Bit[3:0]: pll2_divsp
0x0310	PLL_CTRL_10	0x01	RW	Bit[7:3]: Reserved Bit[2:0]: pll2_cp
0x0311	PLL_CTRL_11	0x00	RW	Bit[7:1]: Reserved Bit[0]: pll2_bypass
0x0312	PLL_CTRL_12	0x07	RW	Bit[7:4]: Reserved Bit[3:0]: pll2_div_sa1
0x0313	PLL_CTRL_13	0x01	RW	Bit[7:4]: Reserved Bit[3:0]: pll2_div_dac
0x0314	PLL_CTRL_14	0x00	RW	Bit[7:1]: Reserved Bit[0]: pll2_predivp
0x0315	PLL_CTRL_15	0x00	RW	Bit[7:1]: Reserved Bit[0]: pll2_div_rst_sync
0x0316~ 0x0317	RSVD	–	–	Reserved
0x0318	PLL_CTRL_18	0x00	RW	Bit[7:1]: Reserved Bit[0]: pll1_rst_o

table 7-2 PLL control registers (sheet 3 of 3)

address	register name	default value	R/W	description
0x0319	PLL_CTRL_19	0x00	RW	Bit[7:1]: Reserved Bit[0]: pll2_rst_o

7.3 SCCB and group hold control [0x3100 - 0x3107, 0x31FF - 0x320F]

table 7-3 SCCB and group hold registers (sheet 1 of 2)

address	register name	default value	R/W	description
0x3100~ 0x3105	DEBUG_CTRL	–	–	Debug Control
0x3106	SB_SRB_CTRL0	0x08	RW	Bit[7]: sclk2x_o_en Bit[6]: sclk_o_en Bit[5:3]: arb_ctrl[2:0] Bit[2]: pad_clk_sw Bit[1:0]: ??????? 00:pll_sclk 01:pll_sclk_d2 10:pll_sclk_d4 11:pll_sclk
0x3107	SB_SRB_CTRL1	0x00	RW	Bit[7:6]: Reserved Bit[5]: disable_auto_wake Bit[4]: pd_mipi_dis_aslp Bit[3]: pumpclk_cutoff_byp Bit[2]: pclk_cutoff_byp Bit[1]: clk_cutoff_byp Bit[0]: clk_ctrl
0x31FF	SB_SWITCH	0x01	RW	Bit[7:1]: Debug control Bit[0]: SCCB slave select 0: Select SCCB slave which requires XVCLK 1: Select SCCB slave which does not require XVCLK
0x3200	GROUP_ADR0	0x00	RW	Start Address of Group 0 Buffer Actual start address is {0x3200[3:0], 4'h0}
0x3201	GROUP_ADR1	0x04	RW	Start Address of Group 1 Buffer Actual start Address Is {0x3201[3:0], 4'h0}
0x3202~ 0x3203	RSVD	–	–	Reserved
0x3204	GROUP_LEN0	–	R	Length of Group0

table 7-3 SCCB and group hold registers (sheet 2 of 2)

address	register name	default value	R/W	description
0x3205	GROUP LEN1	–	R	Length of Group1
0x3206~ 0x3207	RSVD	–	–	Reserved
0x3208	GROUP ACCESS	–	W	Bit[7:4]: group_ctrl 0000: Group hold start 0001: Group hold end 0110: Group launch at line blanking 1010: Group launch at vertical blanking 1110: Group launch immediately Others: Debug control Bit[3:0]: Group ID 0000: Group bank 0 0001: Group bank 1 Others: Debug control
0x3209	GROUP0 PERIOD	0x00	RW	Number of Frames to Stay in Group0
0x320A	GROUP1 PERIOD	0x00	RW	Number of Frames to Stay in Group1
0x320B	GRP_SW_CTRL	0x01	RW	Bit[7:6]: Debug control Bit[5]: grp0_start_opt Bit[4]: frame_cnt_trig Bit[3]: group_switch_repeat Bit[2]: Group switch enable Bit[1:0]: Second group select
0x320C	SRAM TEST	0x0F	RW	Bit[7:5]: Debug control Bit[4]: Group hold SRAM test enable Bit[3:0]: Group hold SRAM RM[3:0]
0x320D	GRP_ACT	–	R	Active Group Indicator
0x320E	FM_CNT_GRP0	–	R	Group0 Frame Count
0x320F	FM_CNT_GRP1	–	R	Group 1 Frame Count

7.4 manual AWB_gain control [0x3400 - 0x3406]

table 7-4 manual AWB_gain registers

address	register name	default value	R/W	description
0x3400	AWB RED GAIN	0x04	RW	Bit[7:4]: Debug control Bit[3:0]: AWB red gain[11:8]
0x3401	AWB RED GAIN	0x00	RW	Bit[7:0]: AWB red gain[7:0]
0x3402	AWB GRN GAIN	0x04	RW	Bit[7:4]: Debug control Bit[3:0]: AWB green gain[11:8]
0x3403	AWB GRN GAIN	0x00	RW	Bit[7:0]: AWB green gain[7:0]
0x3404	AWB BLU GAIN	0x04	RW	Bit[7:4]: Debug control Bit[3:0]: AWB blue gain[11:8]
0x3405	AWB BLU GAIN	0x00	RW	Bit[7:0]: AWB blue gain[7:0]
0x3406	AWB MAN CTRL	0x01	RW	Bit[7:1]: Debug control Bit[0]: AWB manual control

7.5 manual AEC/AGC [0x3500 - 0x351D]

table 7-5 manual AEC/AGC registers (sheet 1 of 4)

address	register name	default value	R/W	description
0x3500	LONG EXPO	0x00	RW	Bit[7:4]: Not used Bit[3:0]: Long exposure[19:16]
0x3501	LONG EXPO	0x02	RW	Bit[7:0]: Long exposure[15:8]
0x3502	LONG EXPO	0x00	RW	Bit[7:0]: Long exposure[7:0] Low 4 bits are fraction bits

table 7-5 manual AEC/AGC registers (sheet 2 of 4)

address	register name	default value	R/W	description
0x3503	AEC MANUAL	0x00	RW	Bit[7]: Not used Bit[6]: Digital fraction gain delay option 0: Delay 1 frame 1: Do not delay 1 frame Bit[5]: Gain change delay option 0: Delay 1 frame 1: Do not delay 1 frame Bit[4]: Gain delay option 0: Delay 1 frame 1: Do not delay 1 frame Bit[3]: gain_prec16_en Bit[2]: Gain manual as sensor gain 0: Input gain as real gain format 1: Input gain as sensor gain format Bit[1]: Exposure delay option (must be 0) 0: Delay 1 frame 1: Not used Bit[0]: Exposure change delay option (must be 0) 0: Delay 1 frame 1: Not used
0x3504	RSVD	–	–	Reserved
0x3505	GCVT OPTION	0x00	RW	Gain Conversation Option Bit[7]: dac_finegain_highbit Bit[6]: switch_snr_gain_en Bit[5:4]: Sensor gain fixed bit Bit[3:2]: Sensor gain pregain option (debug only, always set it to 0) Bit[1:0]: Sensor gain option for transferring real gain to sensor gain format
0x3506	RSVD	–	–	Reserved
0x3507	GAIN SHIFT	0x00	RW	Bit[7:2]: Not used Bit[1:0]: Gain shift option 00: No shift 01: Left shift 1 bit 10: Left shift 2 bit 11: Left shift 3 bit
0x3508	LONG GAIN	0x00	RW	Bit[7:5]: Not used Bit[4:0]: Long gain[12:8]

table 7-5 manual AEC/AGC registers (sheet 3 of 4)

address	register name	default value	R/W	description
0x3509	LONG GAIN	0x80	RW	Bit[7:0]: Long gain[7:0] If 0x3503[2] = 0, gain[7:0] is real gain format, where low 4 bits are fraction bits (e.g., 0x10 is 1x gain, 0x28 is 2.5x gain) If 0x3503[2] = 1, gain[7:0] is sensor gain format, gain[7:4] is coarse gain, 00000: 1x, 00001: 2x, 00011: 4x, 00111: 8x, gain[7] is 1, gain[3:0] is fine gain. For example, 0x10 is 1x gain, 0x30 is 2x gain, 0x70 is 4x gain
0x350A	LONG DIGIGAIN	0x04	RW	Bit[7:0]: Long digital gain[13:6]
0x350B	LONG DIGIGAIN	0x00	RW	Bit[7:6]: Not used Bit[5:0]: Long digital gain[5:0] Low 10 bits are fraction bits
0x350C	SHORT GAIN	0x00	RW	Bit[7:5]: Not used Bit[4:0]: Short gain[12:8]
0x350D	SHORT GAIN	0x80	RW	Bit[7:0]: Short gain[7:0]
0x350E	SHORT DIGIGAIN	0x04	RW	Bit[7:0]: Short digital gain[13:6]
0x350F	SHORT DIGIGAIN	0x00	RW	Bit[7:6]: Not used Bit[5:0]: Short digital gain[5:0] Low 10 bits are fraction bits
0x3510	SHORT EXPO	0x00	RW	Bit[7:4]: Not used Bit[3:0]: Short exposure[19:16]
0x3511	SHORT EXPO	0x02	RW	Bit[7:0]: Short exposure[15:8]
0x3512	SHORT EXPO	0x00	RW	Bit[7:0]: Short exposure[7:0] Low 4 bits are fraction bits
0x3513	SNR_GAIN_LONG	–	R	Bit[7]: Reserved Bit[6:0]: snr_gain_l_i[13:8]
0x3514	SNR_GAIN_LONG	–	R	Bit[7:0]: snr_gain_l_i[7:0]
0x3515	FINE_SNR_GAIN_16_LONG	–	R	Bit[7:6]: Reserved Bit[5:0]: fine_snr_gain_16_l_i[5:0]
0x3516	SNR_GAIN_SHORT	–	R	Bit[7]: Reserved Bit[6:0]: snr_gain_s_i[13:8]
0x3517	SNR_GAIN_SHORT	–	R	Bit[7:0]: snr_gain_s_i[7:0]
0x3518	FINE_SNR_GAIN_16_SHORT	–	R	Bit[7:6]: Reserved Bit[5:0]: fine_snr_gain_16_s_i[5:0]
0x3519	FINE GAIN DFT	0x31	RW	Bit[7:6]: Reserved Bit[5:0]: r_fine_snr_gain_16_def_l_o

table 7-5 manual AEC/AGC registers (sheet 4 of 4)

address	register name	default value	R/W	description
0x351A	FINE GAIN DFT	0x20	RW	Bit[7:6]: Reserved Bit[5:0]: r_fine_snr_gain_16_def_s_o
0x351B	FINE GAIN LOW8	0xFF	RW	Bit[7:0]: r_fine_snr_gain_16_low8_l_o
0x351C	FINE GAIN LOW8	0xFF	RW	Bit[7:0]: r_fine_snr_gain_16_low8_s_o
0x351D	FINE GAIN SEL	0x00	RW	Bit[7:2]: Reserved Bit[1]: r_fine_snr_gain_16_sel_s_o Bit[0]: r_fine_snr_gain_16_sel_l_o

7.6 analog control [0x3600 - 0x3684]

table 7-6 analog control registers

address	register name	default value	R/W	description
0x3600~ 0x3665	ANALOG REGISTERS	–	–	Reserved
0x3666	ANA_CORE_6	0x0A	RW	FSIN/VSYNc Input and Output Select Bit[7:4]: Output select 0x0: VSYNc Others: For debug only Bit[3:0]: Internal frame sync input select 0x0: From FSIN pin, used for both frame sync and frame trigger function 0xA: Fixed value 0 Others: For debug purposes
0x3667~ 0x3684	ANALOG REGISTERS	–	–	Reserved

7.7 sensor control [0x3700 - 0x37AF]

table 7-7 sensor control registers

address	register name	default value	R/W	description
0x3700~ 0x37A7	SENSOR CONTROL REGISTERS	–	–	Sensor Control Registers
0x37A8	FIFO_CTRL0_H	0x00	RW	Internal FIFO Control
0x37A9	FIFO_CTRL0_L	0x60	RW	Internal FIFO Control
0x37AA~ 0x37AF	SENSOR CONTROL REGISTERS	–	–	Sensor Control Registers

7.8 timing control [0x3800 - 0x3835, 0x3837]

table 7-8 timing control registers (sheet 1 of 4)

address	register name	default value	R/W	description
0x3800	TIMING_X_ADDR_START	0x00	RW	Array Horizontal Start Point High Byte
0x3801	TIMING_X_ADDR_START	0x00	RW	Array Horizontal Start Point Low Byte
0x3802	TIMING_Y_ADDR_START	0x00	RW	Array Vertical Start Point High Byte
0x3803	TIMING_Y_ADDR_START	0x00	RW	Array Vertical Start Point Low Byte
0x3804	TIMING_X_ADDR_END	0x05	RW	Array Horizontal End Point High Byte
0x3805	TIMING_X_ADDR_END	0x0F	RW	Array Horizontal End Point Low Byte
0x3806	TIMING_Y_ADDR_END	0x03	RW	Array Vertical End Point High Byte
0x3807	TIMING_Y_ADDR_END	0x2F	RW	Array Vertical End Point Low Byte
0x3808	TIMING_X_OUTPUT_SIZE	0x05	RW	ISP Horizontal Output Width High Byte
0x3809	TIMING_X_OUTPUT_SIZE	0x00	RW	ISP Horizontal Output Width Low Byte
0x380A	TIMING_Y_OUTPUT_SIZE	0x03	RW	ISP Vertical Output Height High Byte
0x380B	TIMING_Y_OUTPUT_SIZE	0x20	RW	ISP Vertical Output Height Low Byte
0x380C	TIMING_HTS	0x02	RW	Total Horizontal Timing Size High Byte
0x380D	TIMING_HTS	0xD8	RW	Total Horizontal Timing Size Low Byte
0x380E	TIMING_VTS	0x03	RW	Total Vertical Timing Size High Byte
0x380F	TIMING_VTS	0x8E	RW	Total Vertical Timing Size Low Byte

table 7-8 timing control registers (sheet 2 of 4)

address	register name	default value	R/W	description
0x3810	TIMING_ISP_X_WIN	0x00	RW	ISP Horizontal Windowing Offset High Byte
0x3811	TIMING_ISP_X_WIN	0x08	RW	ISP Horizontal Windowing Offset Low Byte
0x3812	TIMING_ISP_Y_WIN	0x00	RW	ISP Vertical Windowing Offset High Byte
0x3813	TIMING_ISP_Y_WIN	0x08	RW	ISP Vertical Windowing Offset Low Byte
0x3814	TIMING_X_INC	0x11	RW	Bit[7:4]: x_odd_inc Bit[3:0]: x_even_inc
0x3815	TIMING_Y_INC	0x11	RW	Bit[7:4]: y_odd_inc Bit[3:0]: y_even_inc
0x3816~ 0x381F	DEBUG CTRL	–	–	Debug Control
0x3820	TIMING_FORMAT1	0x40	RW	Bit[7]: vsub48_blc_dis Bit[6]: vflip_blc Bit[5:3]: Debug control Bit[2]: Vflip Vertical image flip Bit[1]: Vbinf Vertical binning Bit[0]: Debug control
0x3821	TIMING_FORMAT2	0x00	RW	Bit[7:4]: Debug control Bit[3]: Fman Bit[2]: Mirr Horizontal image mirror Bit[1]: Debug control Bit[0]: Hbin Horizontal binning
0x3822	TIMING_REG22	0x46	RW	Bit[7:5]: addr0_num[3:1] Bit[4:0]: ablc_num[5:1]
0x3823	TIMING_REG23	0x00	RW	Bit[7]: fmt_chg_min_dly (write only) Bit[6]: ext_vs_re Bit[5]: ext_vs_en Bit[4]: r_init_man Bit[3]: vts_no_latch Bit[2:0]: ablc_adj
0x3824	TIMING_CS_RST_FSIN	0x00	RW	CS Reset Value at vs_ext High Byte
0x3825	TIMING_CS_RST_FSIN	0x00	RW	CS Reset Value at vs_ext Low Byte
0x3826	TIMING_RST_FSIN	0x00	RW	R Reset Value at vs_ext High Byte
0x3827	TIMING_RST_FSIN	0x00	RW	R Reset Value at vs_ext Low Byte
0x3828	TIMING_FVTS	0x00	RW	Fractional Vertical Timing Size High Byte
0x3829	TIMING_FVTS	0x00	RW	Fractional Vertical Timing Size Low Byte

table 7-8 timing control registers (sheet 3 of 4)

address	register name	default value	R/W	description
0x382A	TIMING_REG2A	0x00	RW	Bit[7:4]: Debug control Bit[3]: vts_auto_en Bit[1:0]: href_w
0x382B	TIMING_REG2B	0xFA	RW	Bit[7:4]: grp_wr_start Bit[3:0]: tc_r_int_adj
0x382C	TIMING_REG2C	0x05	RW	Bit[7:0]: hts_global_tx[15:8]
0x382D	TIMING_REG2D	0xB0	RW	Bit[7:0]: hts_global_tx[7:0]
0x382E	TIMING_REG2E	0x01	RW	Bit[7:3]: Debug control Bit[2]: r_tc_hts_blank 0: Uniform HTS 1: Separate HTS for global transfer Bit[1]: r_blc_lines_sync_tc 0: tc_href 1: tc_href synced to image line start Bit[0]: r_blc_lines_sync 0: tc_href 1: blc_href synced to image line start
0x382F	TIMING_REG2F	0x04	RW	Bit[7]: r_pd_row_st_opt 0: auto_vbk_st 1: manu_vbk_st Bit[6]: r_pd_row_ed_opt 0: auto_vbk_ed 1: manu_vbk_ed Bit[5]: r_pd_ana_to_sys 0: ana_vbk cover sys_vbk 1: ana_vbk same as sys_vbk Bit[4]: r_pd_sys_to_ana 0: sys_vbk same as ana_vbk 1: sys_vbk covered by ana_vbk 1 Bit[3:0]: r_pd_row_ofst[3:0] Auto offset after vbk_st and before vbk_ed
0x3830	TIMING_TC_R	–	R	Bit[7:0]: System row counter[15:8]
0x3831	TIMING_TC_R	–	R	Bit[7:0] System row counter[7:0]
0x3832	TIMING_REG32	0x00	RW	Bit[7:0]: pd_vbk_st[15:8] Start of power saving in vblank Upper byte reference to row count

table 7-8 timing control registers (sheet 4 of 4)

address	register name	default value	R/W	description
0x3833	TIMING_REG33	0x05	RW	Bit[7:0]: pd_vbk_st[7:0] Start of power saving in vblank Lower byte reference to row count
0x3834	TIMING_REG34	0x00	RW	Bit[7:0]: pd_vbk_ed[15:8] End of power saving in vblank Upper byte reference to row count
0x3835	TIMING_REG35	0x05	RW	Bit[7:0]: pd_vbk_ed[7:0] End of power saving in vblank Lower byte reference to row count
0x3837	DIGITAL BINNING CTRL	0x00	RW	Digital Binning Control Bit[7:5]: Not used Bit[4]: Debug control Bit[3:2]: Horizontal binning control Set to 2'b00 when binning is disabled and 2'b11 when binning is enabled Bit[1]: Horizontal binning summation enable 0: Average 1: Summation Bit[0]: Horizontal digital binning enable

7.9 PWM and strobe control [0x3900 - 0x3904, 0x3910 - 0x391D, 0x3920 - 0x3933]

table 7-9 PWM and strobe control registers (sheet 1 of 3)

address	register name	default value	R/W	description
0x3900	PWM_CTRL_00	0x00	RW	Bit[7:2]: Reserved Bit[1:0]: r_strobe_st_opt
0x3901	PWM_CTRL_01	0x01	RW	Bit[7:0]: r_strobe_row_st[15:8]
0x3902	PWM_CTRL_02	0xB4	RW	Bit[7:0]: r_strobe_row_st[7:0]
0x3903	PWM_CTRL_03	0x00	RW	Bit[7:0]: r_strobe_cs_st[15:8]
0x3904	PWM_CTRL_04	0x00	RW	Bit[7:0]: r_strobe_cs_st[7:0]

table 7-9 PWM and strobe control registers (sheet 2 of 3)

address	register name	default value	R/W	description
0x3910	PWM_CTRL_10	0xFF	RW	Bit[7:0]: div_reg[15:8]
0x3911	PWM_CTRL_11	0xFF	RW	Bit[7:0]: div_reg[7:0]
0x3912	PWM_CTRL_12	0x08	RW	Bit[7:0]: duty_reg[15:8] 0~65535: 0% ~ 100%
0x3913	PWM_CTRL_13	0x00	RW	Bit[7:0]: duty_reg[7:0] 0~65535: 0% ~ 100%
0x3914	PWM_CTRL_14	0x00	RW	Bit[7:0]: led_duty_cycle_low_reg[15:8]
0x3915	PWM_CTRL_15	0x00	RW	Bit[7:0]: led_duty_cycle_low_reg[7:0]
0x3916	PWM_CTRL_16	0x00	RW	Bit[7:2]: Reserved Bit[1:0]: led_average_l_low_reg[9:8]
0x3917	PWM_CTRL_17	0x00	RW	Bit[7:0]: led_average_l_low_reg[7:0]
0x3918	PWM_CTRL_18	0x00	RW	Bit[7:2]: Reserved Bit[1:0]: average_low_reg[9:8]
0x3919	PWM_CTRL_19	0x00	RW	Bit[7:0]: average_low_reg[7:0]
0x391A	PWM_CTRL_1A	0x00	RW	Bit[7:0]: led_duty_cycle_slope_reg
0x391B	PWM_CTRL_1B	0x74	RW	Bit[7:0]: led_pwm_ctrl1
0x391C	PWM_CTRL_1C	0x00	RW	Bit[7:0]: led_pwm_ctrl0
0x391D	PWM_CTRL_1D	0x10	RW	Bit[7:3]: Reserved Bit[2]: strobe_frame_vs_sel Bit[1]: Reserved Bit[0]: pwm_polarity
0x3920	PWM_CTRL_20	0xA5	RW	Bit[7:0]: strobe_pattern[7:0]
0x3921	PWM_CTRL_21	0x00	RW	Bit[7]: strobe_frame_sign_bit 0: Positive delay 1: Negative delay Bit[6:0]: strobe_frame_shift[30:24]
0x3922	PWM_CTRL_22	0x00	RW	Bit[7:0]: strobe_frame_shift[23:16]
0x3923	PWM_CTRL_23	0x00	RW	Bit[7:0]: strobe_frame_shift[15:8]
0x3924	PWM_CTRL_24	0x05	RW	Bit[7:0]: strobe_frame_shift[7:0]
0x3925	PWM_CTRL_25	0x00	RW	Bit[7:0]: div_value[31:24]
0x3926	PWM_CTRL_26	0x00	RW	Bit[7:0]: div_value[23:16]
0x3927	PWM_CTRL_27	0x00	RW	Bit[7:0]: div_value[15:8]
0x3928	PWM_CTRL_28	0x1A	RW	Bit[7:0]: div_value[7:0]
0x3929	PWM_CTRL_29	0x01	RW	Bit[7:0]: r_strobe_row_st[15:8]

table 7-9 PWM and strobe control registers (sheet 3 of 3)

address	register name	default value	R/W	description
0x392A	PWM_CTRL_2A	0xB4	RW	Bit[7:0]: r_strobe_row_st[7:0]
0x392B	PWM_CTRL_2B	0x00	RW	Bit[7:0]: r_strobe_cs_st[15:8]
0x392C	PWM_CTRL_2C	0x10	RW	Bit[7:0]: r_strobe_cs_st[7:0]
0x392D	PWM_CTRL_2D	0x05	RW	Bit[7:0]: step_onerow_man[15:8]
0x392E	PWM_CTRL_2E	0xF2	RW	Bit[7:0]: step_onerow_man[7:0]
0x392F	PWM_CTRL_2F	0x40	RW	Bit[7]: r_strobe_frm_pwen Bit[6]: r_strobe_frm_pwst Bit[5]: r_strobe_pol Bit[4]: r_strobe_step_pix Bit[3]: r_step_onerow_precision_man Bit[2:0]: r_strobe_st_opt
0x3930	PWM_CTRL_30	–	R	Bit[7:0]: led_duty_cycle_low[15:8]
0x3931	PWM_CTRL_31	–	R	Bit[7:0]: led_duty_cycle_low[7:0]
0x3932	PWM_CTRL_32	–	R	Bit[7:0]: div_value[15:8]
0x3933	PWM_CTRL_33	–	R	Bit[7:0]: div_value[7:0]

7.10 low power mode control [0x4F00 - 0x4F0D, 0x4F10 - 0x4F14]

table 7-10 low power mode control registers (sheet 1 of 2)

address	register name	default value	R/W	description
0x4F00	PSV_CTRL	0x00	RW	Bit[7:4]: Reserved Bit[3]: psv_auto_on_dis 0: PSV mode auto enable if VTS > threshold 1: Disable PSV auto on mode, depending on r_psv_mode_en Bit[2]: r_psv_mode_en Bit[1]: Reserved Bit[0]: psv_mode 0: Keep sclk on, frame timing based on sclk 1: Shut off sclk at blanking, frame timing switches to pad_clk domain

table 7-10 low power mode control registers (sheet 2 of 2)

address	register name	default value	R/W	description
0x4F01	AUTO_SLEEP_CTRL	0x00	RW	Bit[7:4]: Reserved Bit[3]: tc_sof_sync_en Bit[2]: vblkp_sync_dis Bit[1:0]: blank_retime_opt
0x4F02	HTS_PAD_CLK	0x00	RW	Bit[7:0]: hts_pad_clk[15:8]
0x4F03	HTS_PAD_CLK	0xB1	RW	Bit[7:0]: hts_pad_clk[7:0]
0x4F04	CS_CNT_INTIAL	0x00	RW	Bit[7:0]: cs_cnt_intial[15:8]
0x4F05	CS_CNT_INTIAL	0x0F	RW	Bit[7:0]: cs_cnt_intial[7:0]
0x4F06	STREAM_ST_OFFS	0x08	RW	Bit[7:0]: r_stream_st_offs[7:0]
0x4F07	PCHG_ST_OFFS	0x08	RW	Bit[7:0]: r_pchg_st_offs[7:0]
0x4F08	CLK_WINP_OFF	0x01	RW	Bit[3:0]: r_clk_winp_off[3:0]
0x4F09	STRM_REA_OFF	0x02	RW	Bit[3:0]: r_strm_rear_offs[3:0]
0x4F0A	PCHG_REA_OFFS	0x02	RW	Bit[3:0]: r_pchg_rear_offs[3:0]
0x4F0B	RSVD	–	–	Reserved
0x4F0C	PSV_AUTO_ON_THRESH	0x10	RW	Bit[7:0]: psv_auto_on_thresh[15:8]
0x4F0D	PSV_AUTO_ON_THRESH	0x00	RW	Bit[7:0]: psv_auto_on_thresh[7:0]
0x4F10	ANA_PSV_PCH	0x00	RW	Bit[7:0]: ana_psv_pch[15:8]
0x4F11	ANA_PSV_PCH	0x18	RW	Bit[7:0]: ana_psv_pch[7:0]
0x4F12	ANA_PSV_STRM	0x0F	RW	Bit[7:0]: ana_psv_strm[15:8]
0x4F13	ANA_PSV_STRM	0x04	RW	Bit[7:0]: ana_psv_strm[7:0]
0x4F14	ANA_PSV_INV	0x00	RW	Bit[7:1]: Reserved Bit[0]: ana_psv_inv

7.11 BIST [0x3E00 - 0x3E12]

table 7-11 BIST control registers (sheet 1 of 2)

address	register name	default value	R/W	description
0x3E00	START_ADDRESS	0x00	RW	Bit[7:0]: start_address[15:8]
0x3E01	START_ADDRESS	0x00	RW	Bit[7:0]: start_address[7:0]
0x3E02	END_ADDRESS	0x0F	RW	Bit[7:0]: end_address[15:8]

table 7-11 BIST control registers (sheet 2 of 2)

address	register name	default value	R/W	description
0x3E03	END_ADDRESS	0xDB	RW	Bit[7:0]: end_address[7:0]
0x3E04	BIST_OP_CNT	0x14	RW	Bit[4:0]: bist_op_cnt
0x3E05	IP_BIST_SPECIAL_DATA	0x00	RW	Bit[7:0]: ip_bist_special_data
0x3E06	SRAM_SELECT	0x03	RW	Bit[5:0]: sram_select
0x3E07	BIST_CONTROL	0x20	RW	Bit[7:0]: bist_control
0x3E08	IP_BIST_ERR_ADDR	–	R	Bit[7:0]: ip_bist_err_addr[15:8]
0x3E09	IP_BIST_ERR_ADDR	–	R	Bit[7:0]: ip_bist_err_addr[7:0]
0x3E0A	IP_BIST_ERR_DATA	–	R	Bit[7:0]: ip_bist_err_data
0x3E0B	IP_BIST_REF_DATA	–	R	Bit[7:0]: ip_bist_ref_data
0x3E0C	BIST_INFO	–	R	Bit[4:0]: bist_info
0x3E0D	BIST_RESULT	–	R	Bit[7:0]: bist_result[23:16]
0x3E0E	BIST_RESULT	–	R	Bit[7:0]: bist_result[15:8]
0x3E0F	BIST_RESULT	–	R	Bit[7:0]: bist_result[7:0]
0x3E10	BIST_TEST_MODE	–	R	Bit[7:0]: bist_test_mode
0x3E11	BIST_DONE	–	R	Bit[0]: bist_done
0x3E12	SRAM DATA DONE	0x00	RW	Bit[7:0]: SRAM data in read only mode

7.12 OTP control [0x3D80 - 0x3D87]

table 7-12 OTP control registers

address	register name	default value	R/W	description
0x3D80	OTP PROGRAM CTRL	0x00	RW	Bit[7]: otp_pgenb_o 0: Not used 1: Program on going Bit[6:1]: Debug control Bit[0]: otp_pgm To start program Write bit 0 to 1
0x3D81	OTP LOAD CTRL	–	R	Bit[7]: pt_load_o 0: Not used 1: Load on going Bit[6:1]: Debug control Bit[0]: otp_rd Writing to this register will start loading data
0x3D82	OTP PROGRAM PULSE	0x40	RW	Bit[7:0]: Control program strobe pulse, by $8 \times T_{sclk}$
0x3D83	OTP LOAD PULSE	0x03	RW	Bit[7:4]: Not used Bit[3:0]: Control load strobe pulse, by T_{sclk}
0x3D84	OPT MODE CTRL	0x01	RW	Bit[7]: program_dis 0: Enable 1: Disable Bit[6]: mode_select 0: Auto mode 1: Manual mode Bit[5:0]: Memory select
0x3D85	OTP START ADDR	0x00	RW	Bit[7:4]: Not used Bit[3:0]: Start address for manual mode
0x3D86	OTP END ADDR	0x1F	RW	Bit[7:4]: Not used Bit[3:0]: End address for manual mode
0x3D87	OTP PS2CS	0x03	RW	Bit[7:4]: Not used Bit[3:0]: PS to CSB time control by sclk

7.13 BLC control [0x4000 - 0x4017, 0x4020 - 0x403F, 0x4042 - 0x4049]

table 7-13 BLC control registers (sheet 1 of 4)

address	register name	default value	R/W	description
0x4000	BLC_CTRL_00	0xCF	RW	Bit[7:4]: r_off_avg_weight_o Bit[3]: r_target_adj_dis_o Bit[2]: r_off_cmp_en_o Bit[1]: r_dither_en_o Bit[0]: r_mf_en_o
0x4001	BLC_CTRL_01	0x20	RW	Bit[7:6]: r_hdr_option_o Bit[5]: r_kcoef_man_en_o Bit[4]: r_off_man_en_o Bit[3]: r_zero_in_out_en_o Bit[2]: r_blk_in_out_en_o Bit[1:0]: r_byp_mode_o
0x4002	BLC_CTRL_02	0x00	RW	Bit[7:3]: Reserved Bit[2:0]: r_blk_lvl_target_o[10:8]
0x4003	BLC_CTRL_03	0x10	RW	Bit[7:0]: r_blk_lvl_target_o[7:0]
0x4004	BLC_CTRL_04	0x00	RW	Bit[7:4]: Not used Bit[3:0]: r_hwin_off_o[11:8]
0x4005	BLC_CTRL_05	0x02	RW	Bit[7:0]: r_hwin_off_o[7:0]
0x4006	BLC_CTRL_06	0x00	RW	Bit[7:4]: Not used Bit[3:0]: r_hwin_pad_o[11:8]
0x4007	BLC_CTRL_07	0x02	RW	Bit[7:0]: r_hwin_pad_o[7:0]
0x4008	BLC_CTRL_08	0x00	RW	Bit[7:4]: Reserved Bit[3:0]: r_up_bl_start_o[3:0]
0x4009	BLC_CTRL_09	0x07	RW	Bit[7:4]: Reserved Bit[3:0]: r_up_bl_end_o[3:0]
0x400A	BLC_CTRL_0A	0xFF	RW	Bit[7:3]: Reserved Bit[2:0]: r_off_lim_th_o[10:8]
0x400B	BLC_CTRL_0B	0xFF	RW	Bit[7:0]: r_off_lim_th_o[7:0]
0x400C	BLC_CTRL_0C	0x00	RW	Bit[7:4]: Reserved Bit[3:0]: r_dn_bl_start_o[3:0]
0x400D	BLC_CTRL_0D	0x07	RW	Bit[7:4]: Reserved Bit[3:0]: r_dn_bl_end_o[3:0]
0x400E	BLC_CTRL_0E	0x00	RW	Bit[7:3]: Reserved Bit[2:0]: r_kcoef_man_o[10:8]
0x400F	BLC_CTRL_0F	0x80	RW	Bit[7:0]: r_kcoef_man_o[7:0]

table 7-13 BLC control registers (sheet 2 of 4)

address	register name	default value	R/W	description
0x4010	BLC_CTRL_10	0x41	RW	Bit[7]: r_up_off_trig_en_o Bit[6]: r_gain_chg_trig_en_o Bit[5]: r_fmt_chg_trig_en_o Bit[4]: r_rst_trig_en_o Bit[3]: r_man_avg_en_o Bit[2]: r_man_trig_o Bit[1]: r_off_frz_en_o Bit[0]: r_off_always_up_o
0x4011	BLC_CTRL_11	0x7F	RW	Bit[7]: Reserved Bit[6]: r_off_chg_mf_en_o Bit[5]: r_fmt_chg_mf_en_o Bit[4]: r_gain_chg_mf_en_o Bit[3]: r_rst_mf_mode_o Bit[2]: r_off_chg_mf_mode_o Bit[1]: r_fmt_chg_mf_mode_o Bit[0]: r_gain_chg_mf_mode_o
0x4012	BLC_CTRL_12	0x00	RW	Bit[7:6]: Reserved Bit[5:0]: r_rst_trig_fn_o
0x4013	BLC_CTRL_13	0x02	RW	Bit[7:6]: Reserved Bit[5:0]: r_fmt_trig_fn_o
0x4014	BLC_CTRL_14	0x02	RW	Bit[7:6]: Reserved Bit[5:0]: r_gain_trig_fn_o
0x4015	BLC_CTRL_15	0x02	RW	Bit[7:6]: Reserved Bit[5:0]: r_off_trig_fn_o
0x4016	BLC_CTRL_16	0x00	RW	Bit[7:3]: Reserved Bit[2:0]: r_off_trig_th_o[10:8]
0x4017	BLC_CTRL_17	0x00	RW	Bit[7:0]: r_off_trig_th_o[7:0]
0x4020	BLC_CTRL_20	0x00	RW	Bit[7:0]: r_off_cmp_th000_o[7:0]
0x4021	BLC_CTRL_21	0x00	RW	Bit[7:0]: r_off_cmp_k000_o[7:0]
0x4022	BLC_CTRL_22	0x00	RW	Bit[7:0]: r_off_cmp_th001_o[7:0]
0x4023	BLC_CTRL_23	0x00	RW	Bit[7:0]: r_off_cmp_k001_o[7:0]
0x4024	BLC_CTRL_24	0x00	RW	Bit[7:0]: r_off_cmp_th010_o[7:0]
0x4025	BLC_CTRL_25	0x00	RW	Bit[7:0]: r_off_cmp_k010_o[7:0]
0x4026	BLC_CTRL_26	0x00	RW	Bit[7:0]: r_off_cmp_th011_o[7:0]
0x4027	BLC_CTRL_27	0x00	RW	Bit[7:0]: r_off_cmp_k011_o[7:0]
0x4028	BLC_CTRL_28	0x00	RW	Bit[7:0]: r_off_cmp_th100_o[7:0]
0x4029	BLC_CTRL_29	0x00	RW	Bit[7:0]: r_off_cmp_k100_o[7:0]
0x402A	BLC_CTRL_2A	0x00	RW	Bit[7:0]: r_off_cmp_th101_o[7:0]

table 7-13 BLC control registers (sheet 3 of 4)

address	register name	default value	R/W	description
0x402B	BLC_CTRL_2B	0x00	RW	Bit[7:0]: r_off_cmp_k101_o[7:0]
0x402C	BLC_CTRL_2C	0x00	RW	Bit[7:0]: r_off_cmp_th110_o[7:0]
0x402D	BLC_CTRL_2D	0x00	RW	Bit[7:0]: r_off_cmp_k110_o[7:0]
0x402E	BLC_CTRL_2E	0x00	RW	Bit[7:0]: r_off_cmp_th111_o[7:0]
0x402F	BLC_CTRL_2F	0x00	RW	Bit[7:0]: r_off_cmp_k111_o[7:0]
0x4030	BLC_CTRL_30	0x00	RW	Bit[7:3]: Reserved Bit[2:0]: r_off_man000_o[10:8]
0x4031	BLC_CTRL_31	0x00	R/W	Bit[7:0]: r_off_man000_o[7:0]
0x4032	BLC_CTRL_32	0x00	RW	Bit[7:3]: Reserved Bit[2:0]: r_off_man001_o[10:8]
0x4033	BLC_CTRL_33	0x00	RW	Bit[7:0]: r_off_man001_o[7:0]
0x4034	BLC_CTRL_34	0x00	RW	Bit[7:3]: Reserved Bit[2:0]: r_off_man010_o[10:8]
0x4035	BLC_CTRL_35	0x00	RW	Bit[7:0]: r_off_man010_o[7:0]
0x4036	BLC_CTRL_36	0x00	RW	Bit[7:3]: Reserved Bit[2:0]: r_off_man011_o[10:8]
0x4037	BLC_CTRL_37	0x00	RW	Bit[7:0]: r_off_man011_o[7:0]
0x4038	BLC_CTRL_38	0x00	RW	Bit[7:3]: Reserved Bit[2:0]: r_off_man100_o[10:8]
0x4039	BLC_CTRL_39	0x00	RW	Bit[7:0]: r_off_man100_o[7:0]
0x403A	BLC_CTRL_3A	0x00	RW	Bit[7:3]: Reserved Bit[2:0]: r_off_man101_o[10:8]
0x403B	BLC_CTRL_3B	0x00	RW	Bit[7:0]: r_off_man101_o[7:0]
0x403C	BLC_CTRL_3C	0x00	RW	Bit[7:3]: Reserved Bit[2:0]: r_off_man110_o[10:8]
0x403D	BLC_CTRL_3D	0x00	RW	Bit[7:0]: r_off_man110_o[7:0]
0x403E	BLC_CTRL_3E	0x00	RW	Bit[7:3]: Reserved Bit[2:0]: r_off_man111_o[10:8]
0x403F	BLC_CTRL_3F	0x00	RW	Bit[7:0]: r_off_man111_o[7:0]

table 7-13 BLC control registers (sheet 4 of 4)

address	register name	default value	R/W	description
0x4042	BLC_CTRL_42	0x11	RW	Bit[7]: r_format_trig_beh_o Bit[6]: r_gain_trig_beh_o Bit[5]: r_slope_man_en_o Bit[4]: r_slope_en_o Bit[3:2]: r_manu_cvdn_out_en_o Bit[1]: r_lim_off_en_o Bit[0]: r_mf_dn_en_o
0x4043	BLC_CTRL_43	0x40	RW	Bit[7]: r_2bits_precision_en_o Bit[6]: r_bot_blk_in_en_o Bit[5]: r_dn_off_trig_en_o Bit[4]: r_output_sel_o Bit[3]: r_cvdn_blc_en_man_o Bit[2]: r_cvdn_blc_en_o Bit[1]: r_dc_blc_en_man_o Bit[0]: r_dc_blc_en_o
0x4044	BLC_CTRL_44	0x00	RW	Bit[7:2]: Reserved Bit[1:0]: r_rnd_gain_th_o[9:8]
0x4045	BLC_CTRL_45	0x20	RW	Bit[7:0]: r_rnd_gain_th_o[7:0]
0x4046	BLC_CTRL_46	0x00	RW	Bit[7:0]: r_thre_o[7:0]
0x4047	BLC_CTRL_47	0x00	RW	Bit[7]: r_thre_en_o Bit[6:2]: Reserved Bit[1:0]: r_thre_o[9:8]
0x4048	BLC_CTRL_48	0x00	RW	Bit[7:2]: Reserved Bit[1:0]: r_thre_man_o[9:8]
0x4049	BLC_CTRL_49	0x00	RW	Bit[7:0]: r_thre_man_o[7:0]

7.14 frame control [0x4240 - 0x4244]

table 7-14 frame control registers (sheet 1 of 2)

address	register name	default value	R/W	description
0x4240	FC_CTRL0	0x00	RW	Bit[7:4]: Not used Bit[3]: sof_sel Bit[2]: fcnt_eof_sel Bit[1]: fcnt_mask_dis Bit[0]: fcnt_reset
0x4241	FRAME_ON_NUM	0x00	RW	Bit[7:4]: Not used Bit[3:0]: Frame on number

table 7-14 frame control registers (sheet 2 of 2)

address	register name	default value	R/W	description
0x4242	FRAME OFF NUM	0x00	RW	Bit[7:4]: Not used Bit[3:0]: Frame off number
0x4243	FC CTRL3	0x00	RW	Bit[7]: Not used Bit[6]: rblue_mask_dis Bit[5]: data_mask_dis Bit[4]: valid_mask_dis Bit[3]: href_mask_dis Bit[2]: eof_mask_dis Bit[1]: sof_mask_dis Bit[0]: all_mask_dis
0x4244	FRAME COUNTER	–	R	Bit[7:0]: Frame count

7.15 format control [0x4300 - 0x4307, 0x4311 - 0x4317, 0x4320, 0x4322 - 0x4329]

table 7-15 format control registers (sheet 1 of 2)

address	register name	default value	R/W	description
0x4300	DATA_MAX H	0xFF	RW	Bit[7:0]: Data max[9:2]
0x4301	DATA_MIN H	0x00	RW	Bit[7:0]: Data min[9:2]
0x4302	CLIP L	0x0C	RW	Bit[7:4]: Not used Bit[3:2]: Data max[1:0] Bit[1:0]: Data min[1:0]
0x4303	FORMAT CTRL3	0x00	RW	Bit[7]: r_inc_en Bit[6]: r_inc_pattern Bit[5]: r_pad_lsb Bit[4]: r_bar_mux Bit[3]: r_bar_en Bit[2]: r_bit_shift_tst_en Bit[1]: r_tst_bit8 Bit[0]: r_bit_shift_tst_md
0x4304	FORMAT CTRL4	0x08	RW	Bit[7]: Not used Bit[6:4]: data_bit_swap Bit[3]: tst_full_win Bit[2:0]: bar_pad
0x4305~ 0x4306	RSVD	–	–	Reserved

table 7-15 format control registers (sheet 2 of 2)

address	register name	default value	R/W	description
0x4307	EMBED_CTRL	0x30	RW	Bit[7:4]: embed_st Bit[3]: emb_st_man Bit[2]: Reserved Bit[1]: emb_byte_order Bit[0]: emb_en
0x4311	VSYNC_WIDTH_H	0x04	RW	Bit[7:0]: VSYNC width[15:8] (in terms of pixel numbers)
0x4312	VSYNC_WIDTH_L	0x00	RW	Bit[7:0]: VSYNC width[7:0] (in terms of pixel numbers)
0x4313	VSYNC_CTRL	0x00	RW	Bit[7:5]: Not used Bit[4]: VSYNC polarity Bit[3:2]: VSYNC output select Bit[1]: VSYNC mode 3 Bit[0]: VSYNC mode 2
0x4314	VSYNC_DELAY1	0x00	RW	Bit[7:0]: VSYNC trigger to VSYNC delay[23:16]
0x4315	VSYNC_DELAY2	0x01	RW	Bit[7:0]: VSYNC trigger to VSYNC delay[15:8]
0x4316	VSYNC_DELAY3	0x00	RW	Bit[7:0]: VSYNC trigger to VSYNC delay[7:0]
0x4317	MIPI/DVP MODE OPTION	0x00	RW	Bit[7:1]: Reserved Bit[0]: DVP enable
0x4320	TST PATTERN CTRL	0x80	RW	Bit[7:6]: Pixel order 00: P3P4/P1P2 01: P4P3/P2P1 10: P1P2/P3P4 11: P2P1/P4P3 Bit[5]: byte_swap Bit[4:2]: Debug control Bit[1]: Solid test pattern enable 0: Solid test pattern OFF 1: Solid test pattern enable Bit[0]: Debug control
0x4322	SOLID_P1_H	0x00	RW	P1 Value for Solid Test Pattern MSB
0x4323	SOLID_P1_L	0x00	RW	P1 Value for Solid Test Pattern LSB
0x4324	SOLID_P2_H	0x00	RW	P2 Value for Solid Test Pattern MSB
0x4325	SOLID_P2_L	0x00	RW	P2 Value for Solid Test Pattern LSB
0x4326	SOLID_P4_H	0x00	RW	P4 Value for Solid Test Pattern MSB
0x4327	SOLID_P4_L	0x00	RW	P4 Value for Solid Test Pattern LSB
0x4328	SOLID_P3_H	0x00	RW	P3 Value for Solid Test Pattern MSB
0x4329	SOLID_P3_L	0x00	RW	P3 Value for Solid Test Pattern LSB

7.16 VFIFO control [0x4600 ~ 0x4602]

table 7-16 VFIFO control registers

address	register name	default value	R/W	description
0x4600	READ START H	0x00	RW	VFIFO Read Start Point High Byte
0x4601	READ START L	0x04	RW	VFIFO Read Start Point Low Byte
0x4602	VFIFO CTRL2	0xF2	RW	Bit[7:4]: r_rm Bit[3]: r_test1 Bit[2]: Debug control Bit[1]: Frame reset enable Bit[0]: RAM bypass enable

7.17 DVP control [0x4701 ~ 0x4709, 0x470C, 0x470F]

table 7-17 DVP control registers (sheet 1 of 2)

address	register name	default value	R/W	description
0x4701	VSYNCOUT_SEL	0x00	RW	Bit[7:2]: Reserved Bit[1:0]: VSYNC output select 00: eof_o 01: Output gpo_vsync 10: Output hsync_o 11: eof_o
0x4702	VSYNC_RISE_LNT	0x00	RW	Bit[7:0]: vsync_rise_int[15:8] Line counter that controls rising position of VSYNC
0x4703	VSYNC_RISE_LNT	0x02	RW	Bit[7:0]: vsync_rise_int[7:0] Line counter that controls rising position of VSYNC
0x4704	VSYNC_FALL_LNT	0x00	RW	Bit[7:0]: vsync_fall_int[15:8] Line counter that controls falling position of VSYNC
0x4705	VSYNC_FALL_LNT	0x06	RW	Bit[7:0]: vsync_fall_int[7:0] Line counter that controls falling position of VSYNC
0x4706	VSYNC_CHG_PCNT	0x00	RW	Bit[7:0]: vsync_chg_pcmt[15:8] VSYNC change position indicated by pixel position

table 7-17 DVP control registers (sheet 2 of 2)

address	register name	default value	R/W	description
0x4707	VSYNC_CHG_PCNT	0x10	RW	Bit[7:0]: vsync_chg_pcmt[7:0] VSYNC change position indicated by pixel position
0x4708	POLARITY_CTRL	0x09	RW	Bit[7]: Clock DDR mode enable Bit[6]: hts_man_en Bit[5]: VSYNC gate enable Bit[4]: HREF gate enable Bit[3]: r_fo_nofrst Bit[2]: HREF polarity Bit[1]: VSYNC polarity Bit[0]: PCLK polarity
0x4709	BIT_TEST_ORDER	0x00	RW	Bit[7]: Reserved Bit[6:4]: Data bit swap Bit[3:0]: Reserved
0x470C	R_READ_CTRL	0x81	RW	Bit[7:2]: Reserved Bit[1]: first_lv_sel Bit[0]: r_lpcnt_free
0x470F	BYP_SEL	0x00	RW	Bit[7:5]: Reserved Bit[4]: href_sel Bit[3:0]: bypass_sel

7.18 MIPI top [0x4800 - 0x4808, 0x4810 - 0x483D, 0x484A- 0x484F]

table 7-18 MIPI top control registers (sheet 1 of 8)

address	register name	default value	R/W	description
0x4800	MIPI_CTRL00	0x04	RW	Bit[7:6]: Reserved Bit[5]: gate_sc_en 0: Clock lane is free running 1: Gate clock lane when there is no packet to transmit Bit[4]: line_sync_en 0: Do not send line short packet for each line 1: Send line short packet for each line Bit[2]: pclk_inv_o 0: Use falling edge of mipi_pclk_o to generate MIPI bus to PHY 1: Use rising edge of mipi_pclk_o to generate MIPI bus to PHY Bit[1]: firt_bit Change clk_lane first bit 0: Output 8'h55 1: Output 8'hAA Bit[0]: LPX_select for pclk domain 0: Auto calculate t_lpx_p, unit pclk2x cycle 1: Use lpx_p_min[7:0]
0x4801	RSVD	-	-	Reserved

table 7-18 MIPI top control registers (sheet 2 of 8)

address	register name	default value	R/W	description
0x4802	MIPI_CTRL02	0x00	RW	Bit[7]: hs_prepare_sel 0: Auto calculate T_hs_prepare, unit pclk2x 1: Use hs_prepare_min_o[7:0] Bit[6]: clk_prepare_sel 0: Auto calculate T_clk_prepare, unit pclk2x 1: Use clk_prepare_min_o[7:0] Bit[5]: clk_post_sel 0: Auto calculate T_clk_post, unit pclk2x 1: Use clk_post_min_o[7:0] Bit[4]: clk_trail_sel 0: Auto calculate T_clk_trail, unit pclk2x 1: Use clk_trail_min_o[7:0] Bit[3]: hs_exit_sel 0: Auto calculate T_hs_exit, unit pclk2x 1: Use hs_exit_min_o[7:0] Bit[2]: hs_zero_sel 0: Auto calculate T_hs_zero, unit pclk2x 1: Use hs_zero_min_o[7:0] Bit[1]: hs_trail_sel 0: Auto calculate T_hs_trail, unit pclk2x 1: Use hs_trail_min_o[7:0] Bit[0]: clk_zero_sel 0: Auto calculate T_clk_zero, unit pclk2x 1: Use clk_zero_min_o[7:0]
0x4803	MIPI_CTRL03	0x10	RW	Bit[7:5]: Reserved Bit[4]: pu_mark_en_o Bit[3]: manu_offset_o t_perio manual offset SMIA Bit[2]: r_manual_half2one t_period half to 1 SMIA Bit[1:0]: Reserved
0x4804	RSVD	–	–	Reserved
0x4805	MIPI_CTRL05	0x00	RW	Bit[7:4]: Reserved Bit[3]: lpda_retim_manu_o Bit[2]: lpda_retim_sel_o 1: Manual Bit[1]: lpck_retim_manu_o Bit[0]: lpck_retim_sel_o 1: Manual

table 7-18 MIPI top control registers (sheet 3 of 8)

address	register name	default value	R/W	description
0x4806	MIPI_CTRL06	0x00	RW	Bit[7:5]: Reserved Bit[4]: pu_mark_en_o Power up mark1 enable Bit[3]: mipi_remot_rst Bit[2]: mipi_susp Bit[1]: mipi_ul_auto_en Bit[0]: tx_lsb_first 0: High bit first 1: Low power transmit low bit first
0x4807	MIPI_CTRL07	0x03	RW	Bit[7:4]: Reserved Bit[3:0]: sw_t_lpx ul_tx T_lpx
0x4808	MIPI_CTRL08	0x18	RW	Bit[7:0]: wkup_dly Mark1 wakeup delay/2^10
0x4810	MIPI_FCNT_MAX	0xFF	RW	High Byte of Maximum Frame Counter of Frame Sync Short Packet
0x4811	MIPI_FCNT_MAX	0xFF	RW	Low Byte of Maximum Frame Counter of Frame Sync Short Packet
0x4812	RSVD	–	–	Reserved
0x4813	MIPI_CTRL13	0x00	RW	Bit[7:3]: Reserved Bit[2]: vc_sel Input VC or reg VC Bit[1:0]: VC Virtual channel of MIPI
0x4814	MIPI_CTRL14	0x2A	RW	Bit[7]: Reserved Bit[6]: lpkt_dt_sel 0: Use mipi_dt 1: Use dt_man_o as long packet data Bit[5:0]: dt_man Manual data type
0x4815~ 0x4817	RSVD	–	–	Reserved
0x4818	MIPI_HS_ZERO_MIN	0x00	RW	Bit[7:2]: Reserved Bit[1:0]: hs_zero_min[9:8] High byte of minimum value of hs_zero, unit ns
0x4819	MIPI_HS_ZERO_MIN	0x70	RW	Bit[7:0]: hs_zero_min[7:0] Low byte of minimum value of hs_zero, unit ns hs_zero_real = hs_zero_min_o + Tui*ui_hs_zero_min_o

table 7-18 MIPI top control registers (sheet 4 of 8)

address	register name	default value	R/W	description
0x481A	MIPI_HS_TRAIL_MIN	0x00	RW	Bit[7:2]: Reserved Bit[1:0]: hs_trail_min[9:8] High byte of minimum value of hs_trail, unit ns
0x481B	MIPI_HS_TRAIL_MIN	0x3C	RW	Bit[7:0]: hs_trail_min[7:0] Low byte of minimum value of hs_trail, unit ns hs_trail_real = hs_trail_min_o + Tui*ui_hs_trail_min_o
0x481C	MIPI_CLK_ZERO_MIN	0x01	RW	Bit[7:2]: Reserved Bit[1:0]: clk_zero_min[9:8] High byte of minimum value of clk_zero, unit ns
0x481D	MIPI_CLK_ZERO_MIN	0x2C	RW	Bit[7:0]: clk_zero_min[7:0] Low byte of minimum value of clk_zero, unit ns clk_zero_real = clk_zero_min_o + Tui*ui_clk_zero_min_o
0x481E	MIPI_CLK_PREPARE_MIN	0x5F	RW	Bit[7:0]: clk_prepare_max Maximum value of clk_prepare, unit ns
0x481F	MIPI_CLK_PREPARE_MIN	0x26	RW	Bit[7:0]: clk_prepare_min Minimum value of clk_prepare, unit ns
0x4820	MIPI_CLK_POST_MIN	0x00	RW	Bit[7:2]: Reserved Bit[1:0]: clk_post_min[9:8] High byte of minimum value of clk_post, unit ns
0x4821	MIPI_CLK_POST_MIN	0x3C	RW	Bit[7:0]: clk_post_min[7:0] Low byte of minimum value of clk_post, unit ns clk_post_real = clk_post_min_o + Tui*ui_clk_post_min_o
0x4822	MIPI_CLK_TRAIL_MIN	0x00	RW	Bit[7:2]: Reserved Bit[1:0]: clk_trail_min[9:8] High byte of minimum value of clk_trail, unit ns
0x4823	MIPI_CLK_TRAIL_MIN	0x3C	RW	Bit[7:0]: clk_trail_min[7:0] Low byte of minimum value of clk_trail, unit ns clk_trail_real = clk_trail_min_o + Tui*ui_clk_trail_min_o

table 7-18 MIPI top control registers (sheet 5 of 8)

address	register name	default value	R/W	description
0x4824	MIPI_LPX_P_MIN	0x00	RW	Bit[7:2]: Reserved Bit[1:0]: lpx_p_min[9:8] High byte of minimum value of lpx_p, unit ns
0x4825	MIPI_LPX_P_MIN	0x32	RW	Bit[7:0]: lpx_p_min[7:0] Low byte of minimum value of lpx_p, unit ns $lpx_p_real = lpx_p_min_o + Tui * ui_lpx_p_min_o$
0x4826	MIPI_HS_PREPARE_MIN	0x32	RW	Bit[7:0]: hs_prepare_min Minimum value of hs_prepare, unit ns
0x4827	MIPI_HS_PREPARE_MAX	0x55	RW	Bit[7:0]: hs_prepare_max Maximum value of hs_prepare, unit ns
0x4828	MIPI_HS_EXIT_MIN	0x00	RW	Bit[7:2]: Reserved Bit[1:0]: hs_exit_min[9:8] High byte of minimum value of hs_exit, unit ns
0x4829	MIPI_HS_EXIT_MIN	0x64	RW	Bit[7:0]: hs_exit_min[7:0] Low byte of minimum value of hs_exit, unit ns $hs_exit_real = hs_exit_min_o + Tui * ui_hs_exit_min_o$
0x482A	MIPI_UI_HS_ZERO_MIN	0x06	RW	Minimum UI Value of hs_zero, unit UI
0x482B	MIPI_UI_HS_TRAIL_MIN	0x04	RW	Minimum UI Value of hs_trail, unit UI
0x482C	MIPI_UI_CLK_ZERO_MIN	0x00	RW	Minimum UI Value of clk_zero, unit UI
0x482D	MIPI_UI_CLK_PREPARE_MIN	0x00	RW	Minimum UI Value of clk_prepare, unit UI
0x482E	MIPI_UI_CLK_POST_MIN	0x34	RW	Minimum UI Value of clk_post, unit UI
0x482F	MIPI_UI_CLK_TRAIL_MIN	0x00	RW	Minimum UI Value of clk_trail, unit UI
0x4830	MIPI_UI_LPX_P_MIN	0x00	RW	Minimum UI Value of lpx_p (pclk2x domain), unit UI
0x4831	MIPI_UI_HS_PREPARE	0x64	RW	Bit[7:4]: ui_hs_prepare_max Maximum UI value of hs_prepare, unit UI Bit[3:0]: ui_hs_prepare_min Minimum UI value of hs_prepare, unit UI
0x4832	MIPI_UI_HS_EXIT_MIN	0x00	RW	Minimum UI Value of hs_exit, unit UI

table 7-18 MIPI top control registers (sheet 6 of 8)

address	register name	default value	R/W	description
0x4833	MIPI_PKT_START_SIZE	0x06	RW	Bit[7:6]: Reserved Bit[5:0]: mipi_pkt_start_size[5:0]
0x4834~ 0x4836	RSVD	–	–	Reserved
0x4837	MIPI_PCLK_PERIOD	0x10	RW	Period of pclk2x, pclk_div=1, and 1 bit decimal
0x4838	MIPI_LP_GPIO0	0x00	RW	Bit[7]: lp_sel0 0: Auto gen mipi_lp_dir0_o 1: Use lp_dir_man0 to be mipi_lp_dir0_o Bit[6]: lp_dir_man0 0: Input 1: Output Bit[5]: lp_p0_o Bit[4]: lp_n0_o Bit[3]: lp_sel1 0: Auto gen mipi_lp_dir1_o 1: Use lp_dir_man1 to be mipi_lp_dir1_o Bit[2]: lp_dir_man1 0: Input 1: Output Bit[1]: lp_p1_o Bit[0]: lp_n1_o
0x4839	MIPI_LP_GPIO1	0x00	RW	Bit[7]: lp_sel2 0: Auto gen mipi_lp_dir2_o 1: Use lp_dir_man2 to be mipi_lp_dir2_o Bit[6]: lp_dir_man2 0: Input 1: Output Bit[5]: lp_p2_o Bit[4]: lp_n2_o Bit[3]: lp_sel3 0: Auto gen mipi_lp_dir3_o 1: Use lp_dir_man3 to be mipi_lp_dir3_o Bit[2]: lp_dir_man3 0: Input 1: Output Bit[1]: lp_p3_o Bit[0]: lp_n3_o
0x483A~ 0x483B	RSVD	–	–	Reserved
0x483C	MIPI_CTRL33	0x02	RW	Bit[7:4]: Reserved Bit[3:0]: t_clk_pre unit pclk2x cycle

table 7-18 MIPI top control registers (sheet 7 of 8)

address	register name	default value	R/W	description
0x483D	MIPI_LP_GPIO4	0x00	RW	Bit[7]: lp_ck_sel0 0: Auto gen mipi_ck_lp_dir0_o 1: Use lp_ck_dir_man0 to be mipi_ck_lp_dir0_o Bit[6]: lp_ck_dir_man0 0: Input 1: Output Bit[5]: lp_ck_p0_o Bit[4]: lp_ck_n0_o Bit[3]: lp_ck_sel1 0: Auto gen mipi_ck_lp_dir1_o 1: Use lp_ck_dir_man1 to be mipi_ck_lp_dir1_o Bit[2]: lp_ck_dir_man1 0: Input 1: Output Bit[1]: lp_ck_p1_o Bit[0]: lp_ck_n1_o
0x484A	MIPI_CTRL4A	0x3F	RW	Bit[7:6]: Reserved Bit[5]: slp_lp_pon_man_o Set for power up Bit[4]: slp_lp_pon_da Bit[3]: slp_lp_pon_ck Bit[2]: mipi_slp_man_st MIPI bus status manual control enable in sleep mode Bit[1]: clk_lane_state Bit[0]: data_lane_state
0x484B	MIPI_CTRL4B	0x07	RW	Bit[7:2]: Reserved Bit[1]: clk_start_sel_o 0: Clock starts after SOF 1: Clock starts after reset Bit[0]: sof_sel_o 0: Frame starts after HREF occurs 1: Frame starts after SOF
0x484C	MIPI_CTRL4C	0x00	RW	Bit[7:4]: Reserved Bit[3]: SMIA fcnt_i select Bit[2]: PRBS enable Bit[1]: hs_test_only MIPI high speed only test mode enable Bit[0]: Set frame count to inactive mode (keep 0)
0x484D	TEST_PATTEN_DATA	0xB6	RW	Data Lane Test Pattern Register
0x484E	FE_DLY	0x10	RW	Last Packet to Frame End Delay / 2

table 7-18 MIPI top control registers (sheet 8 of 8)

address	register name	default value	R/W	description
0x484F	TEST_PATTEN_CHK_DATA	0x55	RW	clk_test_patten_reg

7.19 ISP top [0x5000 - 0x5018, 0x5020 - 0x5024, 0x5030 - 0x5035, 0x5E00 - 0x5E2E]

table 7-19 ISP top registers (sheet 1 of 6)

address	register name	default value	R/W	description
0x5000	ISP CTRL 00	0x9F	RW	Bit[7:6]: isp_sof_sel Bit[5]: isp_eof_sel Bit[4]: bc_en Bit[3]: wc_en Bit[2]: dpc_buf_en Bit[1]: awbg_en Bit[0]: blc_en
0x5001	ISP CTRL 01	0x00	RW	Bit[7]: dgc_en Bit[6:5]: Reserved Bit[4]: latch_en Bit[3]: r_size_man Bit[2]: r_pre_isp_raw_en Bit[1]: bypass_isp1 Bit[0]: bypass_isp0
0x5002	ISP CTRL 02	0x00	RW	Bit[7:3]: Reserved Bit[2:0]: manual_x_addr_st[10:8]
0x5003	ISP CTRL 03	0x00	RW	Bit[7:0]: manual_x_addr_st[7:0]
0x5004	ISP CTRL 04	0x00	RW	Bit[7:1]: Reserved Bit[1:0]: manual_y_addr_st[9:8]
0x5005	ISP CTRL 05	0x00	RW	Bit[7:0]: manual_y_addr_st[7:0]
0x5006	ISP CTRL 06	0x05	RW	Bit[7:3]: Reserved Bit[2:0]: manual_x_addr_end[10:8]
0x5007	ISP CTRL 07	0x0F	RW	Bit[7:0]: manual_x_addr_end[7:0]
0x5008	ISP CTRL 08	0x03	R/W	Bit[7:1]: Reserved Bit[1:0]: manual_y_addr_end[9:8]
0x5009	ISP CTRL 09	0x2F	R/W	Bit[7:0]: manual_y_addr_end[7:0]
0x500A~ 0x500F	RSVD	–	–	Reserved

table 7-19 ISP top registers (sheet 2 of 6)

address	register name	default value	R/W	description
0x5010	LINEAR_GAIN	–	R	Bit[1:0]: AEC linear gain debug[9:8]
0x5011	LINEAR_GAIN	–	R	Bit[7:0]: AEC linear gain debug[7:0]
0x5012	AWB_GAIN_R	–	R	Bit[3:0]: AWB gain R channel[11:8]
0x5013	AWB_GAIN_R	–	R	Bit[7:0]: AWB gain R channel[7:0]
0x5014	AWB_GAIN_G	–	R	Bit[3:0]: AWB gain G channel[11:8]
0x5015	AWB_GAIN_G	–	R	Bit[7:0]: AWB gain G channel[7:0]
0x5016	AWB_GAIN_B	–	R	Bit[3:0]: AWB gain B channel[11:8]
0x5017	AWB_GAIN_B	–	R	Bit[7:0]: AWB gain B channel[7:0]
0x5018	SENSOR_BIAS	–	R	Sensor Bias Debug
0x5020	ISP_CTRL_20	0x00	RW	Bit[7]: Reserved Bit[6]: blc_px_man_en Bit[5:4]: blc_px_man Bit[3]: blc_vsync_sel Bit[2]: dig_gain_blc_man Bit[1:0]: dig_gain_blc
0x5021	ISP_CTRL_21	0x00	RW	Bit[7:4]: Reserved Bit[3]: r_blc_rblue_man_en Bit[2]: r_blc_rblue_man Bit[1]: r_blc_target_sel 0: blc_target[7:0] 1: blc_target[9:2] Bit[0]: r_bias_man_en
0x5022	ISP_CTRL_22	0x00	RW	Bit[7:0]: r_bias_man_value
0x5023	ISP_CTRL_23	0x02	RW	Bit[7:6]: Reserved Bit[5]: r_dig_4x Bit[4]: r_dig_2x Bit[3:2]: Reserved Bit[1:0]: r_dig_comp[9:8]
0x5024	ISP_CTRL_24	0x00	RW	Bit[7:0]: r_dig_comp[7:0]
0x5030	ISP_CTRL_30	0x00	RW	Bit[7]: Reserved Bit[6]: dpc_px_man_en Bit[5:4]: dpc_px_man Bit[3]: r_cen Bit[2]: r_cen_sel Bit[1]: dpc_size_man Bit[0]: dpc_data_switch
0x5031	ISP_CTRL_31	0x00	RW	Bit[7:0]: dpc_hsize_in[7:0]
0x5032	ISP_CTRL_32	0x00	RW	Bit[7:3]: Reserved Bit[2:0]: dpc_hsize_in[10:8]

table 7-19 ISP top registers (sheet 3 of 6)

address	register name	default value	R/W	description
0x5033	ISP_CTRL_33	0x00	RW	Bit[7:0]: dpc_vsize_in[7:0]
0x5034	ISP_CTRL_34	0x00	RW	Bit[7:2]: Reserved Bit[1:0]: dpc_vsize_in[9:8]
0x5035	ISP_CTRL_35	0x0F	RW	Bit[7:6]: Reserved Bit[5]: r_dpc_sram_rme1 Bit[4]: r_dpc_sram_test1 Bit[3:0]: r_dpc_sram_rm1
0x5E00	PRE_CTRL00	0x00	RW	Bit[7]: Test pattern enable Bit[6]: Rolling bar function enable Bit[5]: Transparent enable Bit[4]: Square mode 0: Gray scale squares 1: Black-white squares Bit[3:2]: Test pattern bar style 00: Standard test pattern bar 01: Top-bottom darker test pattern bar 10: Right-left darker test pattern bar 11: Bottom-top darker test pattern bar Bit[1:0]: Test pattern mode 00: Test pattern bar 01: Random data 10: Square 11: Black image
0x5E01	PRE_CTRL01	0x41	RW	Bit[7]: Reserved Bit[6]: Window cut enable Bit[5]: two_lsb_0_en Set lowest two bits to 0 Bit[4]: Same seed enable Reset seed to 0x5E01[3:0] each frame Bit[3:0]: Random seed Seed used in generating random data
0x5E02	PRE_CTRL02	0x00	RW	Bit[7:4]: Reserved Bit[3:0]: Line number interrupt[11:8]
0x5E03	PRE_CTRL03	0x01	RW	Bit[7:0]: Line number interrupt[7:0]
0x5E04	PRE_CTRL04	0x00	RW	Bit[7:0]: Scale x input manual size[15:8]
0x5E05	PRE_CTRL05	0x00	RW	Bit[7:0]: Scale x input manual size[7:0]
0x5E06	PRE_CTRL06	0x01	RW	Bit[7:0]: Scale y input manual size[15:8]
0x5E07	PRE_CTRL07	0x00	RW	Bit[7:0]: Scale y input manual size[7:0]

table 7-19 ISP top registers (sheet 4 of 6)

address	register name	default value	R/W	description
0x5E08	PRE_CTRL08	0x00	RW	Bit[7:4]: Reserved Bit[3:0]: Horizontal manual offset[11:8]
0x5E09	PRE_CTRL09	0x00	RW	Bit[7:0]: Horizontal manual offset[7:0]
0x5E0A	PRE_CTRL0A	0x00	RW	Bit[7:4]: Reserved Bit[3:0]: Vertical manual offset[11:8]
0x5E0B	PRE_CTRL0B	0x00	RW	Bit[7:0]: Vertical manual offset[7:0]
0x5E0C	PRE_RO0C	–	R	Bit[7:4]: Reserved Bit[3:0]: Input image pixel number[11:8]
0x5E0D	PRE_RO0D	–	R	Bit[7:0]: Input image pixel number[7:0]
0x5E0E	PRE_RO0E	–	R	Bit[7:4]: Reserved Bit[3:0]: Input image line number[11:8]
0x5E0F	PRE_RO0F	–	R	Bit[7:0]: Input image line number[7:0]
0x5E10	PRE_CTRL10	0x3C	R/W	Bit[7]: Window X offset option Bit[6]: Window Y offset option Bit[5]: Take first pixel in the same position with no mirror image enable Bit[4]: Take first pixel in same position with no flip image enable Bit[3]: Mirror option from window 0: First pixel is P2 or P4 with window output 1: First pixel is P1 or P3 with window output Bit[2]: Flip option from window 0: First line is P3P4 with window output 1: First line is P1P2 with window output Bit[1]: Offset manual enable Bit[0]: Scale size manual enable
0x5E11	PRE_CTRL11	0x00	R/W	Bit[7]: Manual clock/valid ratio enable Bit[6:4]: Manual dummy line number Bit[3]: Reduce HREF low length by half Bit[2:0]: Manual clock/valid ratio for dummy line
0x5E12	PRE_RO12	–	R	Bit[7:0]: HREF blank length for dummy line[15:8]
0x5E13	PRE_RO13	–	R	Bit[7:0]: HREF blank length for dummy line[7:0]
0x5E14	PRE_RO14	–	R	Bit[7:0]: HREF length for dummy line[15:8]

table 7-19 ISP top registers (sheet 5 of 6)

address	register name	default value	R/W	description
0x5E15	PRE RO15	–	R	Bit[7:0]: HREF length for dummy line[7:0]
0x5E16	PRE RO16	–	R	Bit[7:5]: Reserved Bit[4]: Dummy error indicating signal Bit[3]: Reserved Bit[2:0]: Dummy line clock ratio output
0x5E17	PRE RO17	–	R	Bit[7:4]: Horizontal odd increase step Bit[3:0]: Vertical odd increase step
0x5E18	PRE RO18	–	R	Bit[7:4]: Reserved Bit[3:0]: Horizontal sensor offset[11:8]
0x5E19	PRE RO19	–	R	Bit[7:0]: Horizontal sensor offset[7:0]
0x5E1A	PRE RO1A	–	R	Bit[7:4]: Reserved Bit[3:0]: Vertical sensor offset[11:8]
0x5E1B	PRE RO1B	–	R	Bit[7:0]: Vertical sensor offset[7:0]
0x5E1C	PRE RO1C	–	R	Bit[7:4]: Reserved Bit[3:0]: Horizontal window offset[11:8]
0x5E1D	PRE RO1D	–	R	Bit[7:0]: Horizontal window offset[7:0]
0x5E1E	PRE RO1E	–	R	Bit[7:4]: Reserved Bit[3:0]: Vertical window offset[11:8]
0x5E1F	PRE RO1F	–	R	Bit[7:0]: Vertical window offset[7:0]
0x5E20	PRE RO20	–	R	Bit[7:5]: Reserved Bit[4:0]: Horizontal window output size[12:8]
0x5E21	PRE RO21	–	R	Bit[7:0]: Horizontal window output size[7:0]
0x5E22	PRE RO22	–	R	Bit[7:4]: Reserved Bit[3:0]: Vertical window output size[11:8]
0x5E23	PRE RO23	–	R	Bit[7:0]: Vertical window output size[7:0]
0x5E24	PRE RO24	–	R	Bit[7:6]: Reserved Bit[5:4]: Horizontal skip Bit[3:2]: Reserved Bit[1:0]: Vertical skip
0x5E25	PRE RO25	–	R	Bit[7:4]: Horizontal even increase step Bit[3:0]: Vertical even increase step
0x5E26	RSVD	–	–	Reserved
0x5E27	PRE RO27	–	R	Bit[7:4]: Reserved Bit[3:0]: Cut top offset for bi-linear BLC[11:8]
0x5E28	PRE RO28	–	R	Bit[7:0]: Cut top offset for bi-linear BLC[7:0]

table 7-19 ISP top registers (sheet 6 of 6)

address	register name	default value	R/W	description
0x5E29	PRE RO29	–	R	Bit[7:4]: Reserved Bit[3:0]: Cut bottom offset for bi-linear BLC[11:8]
0x5E2A	PRE RO2A	–	R	Bit[7:0]: Cut bottom offset for bi-linear BLC[7:0]
0x5E2B	PRE CTRL2B	0x09	RW	Bit[7:4]: Reserved Bit[3:0]: Array height for bi-linear BLC[11:8]
0x5E2C	PRE CTRL2C	0xB0	RW	Bit[7:0]: Array height for bi-linear BLC[7:0]
0x5E2D	PRE CTRL2D	0x00	RW	Bit[7:6]: Reserved Bit[5]: Manual horizontal skip enable Bit[4:0]: Reserved
0x5E2E	PRE CTRL2E	0x00	RW	Bit[7:6]: Reserved Bit[5]: Manual vertical skip enable Bit[4:0]: Reserved

7.20 window control [0x5A00 - 0x5A09, 0x5A10 - 0x5A2F]

table 7-20 window control registers (sheet 1 of 5)

address	register name	default value	R/W	description
0x5A00	XSTART MAN	0x00	RW	Bit[7:5]: Reserved Bit[2:0]: x_start[10:8] High byte of manual horizontal start for manual output window
0x5A01	XSTART MAN	0x00	RW	Bit[7:0]: x_start[7:0] Low byte of manual horizontal start for manual output window
0x5A02	YSTART MAN	0x00	RW	Bit[7:4]: Reserved Bit[1:0]: y_start[9:8] High byte of manual vertical start for manual output window
0x5A03	YSTART MAN	0x00	R/W	Bit[7:0]: y_start[7:0] Low byte of manual vertical start for manual output window
0x5A04	XWIN MAN	0x05	R/W	Bit[7:5]: Reserved Bit[2:0]: x_window[10:8] High byte of manual horizontal window for manual output window

table 7-20 window control registers (sheet 2 of 5)

address	register name	default value	R/W	description
0x5A05	XWIN MAN	0x00	R/W	Bit[7:0]: x_window[7:0] Low byte of manual horizontal window for manual output window
0x5A06	YWIN MAN	0x03	R/W	Bit[7:4]: Reserved Bit[1:0]: y_window[9:8] High byte of manual vertical window for manual output window
0x5A07	YWIN MAN	0x20	R/W	Bit[7:0]: y_window[7:0] Low byte of manual vertical window for manual output window
0x5A08	WINC CTRL	0x86	R/W	Bit[7]: r_out_size_sel 0: Initial XY size out 1: ROI XY size out Bit[6]: r_one_zone_en 0: 16 zones display 1: Single zone display enable Bit[5]: Reserved Bit[4]: win16_en 0: It is not divided into 16 zones 1: 16 zones crop enable Bit[3]: win_valid_opt Bit[2]: emb_flag_sel Bit[1]: win_en_opt Bit[0]: win_man_en Manual window enable signal 0: Output window uses system parameters 1: Output window uses manual parameters which are set in register 0x5A00~0x5A07
0x5A09	WINC_SEL	0x00	R/W	Bit[7:3]: Reserved Bit[2:1]: roi_sel_man 00: Zone00 [00 01 02 03] 01: Zone05 [04 05 06 07] 10: Zone10 [08 09 10 11] 11: Zone15 [12 13 14 15] Bit[0]: roi_sel_man_en Manual signal zone select 0: Output zone is selected by GPIO pad 1: Output zone is selected by 0x5A09[2:1]
0x5A10	WIN16 XSTART0	0x00	R/W	Bit[7:3]: Reserved Bit[2:0]: win16_xstart0[10:8] High byte of first horizontal start for 16-window function

table 7-20 window control registers (sheet 3 of 5)

address	register name	default value	R/W	description
0x5A11	WIN16 XSTART0	0x00	R/W	Bit[7:0]: win16_xstart0[7:0] Low byte of first horizontal start for 16-window function
0x5A12	WIN16 XSTART1	0x00	R/W	Bit[7:3]: Reserved Bit[2:0]: win16_xstart1[10:8] High byte of first horizontal start for 16-window function
0x5A13	WIN16 XSTART1	0x00	R/W	Bit[7:0]: win16_xstart1[7:0] Low byte of first horizontal start for 16-window function
0x5A14	WIN16 XSTART2	0x02	R/W	Bit[7:3]: Reserved Bit[2:0]: win16_xstart2[10:8] High byte of first horizontal start for 16-window function
0x5A15	WIN16 XSTART2	0x80	R/W	Bit[7:0]: win16_xstart2[7:0] Low byte of first horizontal start for 16-window function
0x5A16	WIN16 XSTART3	0x03	R/W	Bit[7:3]: Reserved Bit[2:0]: win16_xstart3[10:8] High byte of first horizontal start for 16-window function
0x5A17	WIN16 XSTART3	0xC0	R/W	Bit[7:0]: win16_xstart3[7:0] Low byte of first horizontal start for 16-window function
0x5A18	WIN16 YSTART0	0x00	R/W	Bit[7:3]: Reserved Bit[1:0]: win16_ystart0[9:8] High byte of first horizontal start for 16-window function
0x5A19	WIN16 YSTART0	0x00	R/W	Bit[7:0]: win16_ystart0[7:0] Low byte of first horizontal start for 16-window function
0x5A1A	WIN16 YSTART1	0x00	R/W	Bit[7:3]: Reserved Bit[1:0]: win16_ystart1[9:8] High byte of first horizontal start for 16-window function
0x5A1B	WIN16 YSTART1	0x28	R/W	Bit[7:0]: win16_ystart1[7:0] Low byte of first horizontal start for 16-window function
0x5A1C	WIN16 YSTART2	0x01	R/W	Bit[7:3]: Reserved Bit[1:0]: win16_ystart2[9:8] High byte of first horizontal start for 16-window function

table 7-20 window control registers (sheet 4 of 5)

address	register name	default value	R/W	description
0x5A1D	WIN16 YSTART2	0x90	R/W	Bit[7:0]: win16_ystart2[7:0] Low byte of first horizontal start for 16-window function
0x5A1E	WIN16 YSTART3	0x01	R/W	Bit[7:3]: Reserved Bit[1:0]: win16_ystart3[9:8] High byte of first horizontal start for 16-window function
0x5A1F	WIN16 YSTART3	0x90	R/W	Bit[7:0]: win16_ystart3[7:0] Low byte of first horizontal start for 16-window function
0x5A20	WIN16 XWIN0	0x05	R/W	Bit[7:3]: Reserved Bit[2:0]: win16_xwindow0[10:8] High byte of first horizontal window for 16-window function
0x5A21	WIN16 XWIN0	0x00	R/W	Bit[7:0]: win16_xwindow0[7:0] Low byte of first horizontal window for 16-window function
0x5A22	WIN16 XWIN1	0x05	R/W	Bit[7:3]: Reserved Bit[2:0]: win16_xwindow1[10:8] High byte of first horizontal window for 16-window function
0x5A23	WIN16 XWIN1	0x00	R/W	Bit[7:0]: win16_xwindow1[7:0] Low byte of first horizontal window for 16-window function
0x5A24	WIN16 XWIN2	0x02	R/W	Bit[7:3]: Reserved Bit[2:0]: win16_xwindow2[10:8] High byte of first horizontal window for 16-window function
0x5A25	WIN16 XWIN2	0x80	R/W	Bit[7:0]: win16_xwindow2[7:0] Low byte of first horizontal window for 16-window function
0x5A26	WIN16 XWIN3	0x01	RW	Bit[7:3]: Reserved Bit[2:0]: win16_xwindow3[10:8] High byte of first horizontal window for 16-window function
0x5A27	WIN16 XWIN3	0x40	RW	Bit[7:0]: win16_xwindow3[7:0] Low byte of first horizontal window for 16-window function
0x5A28	WIN16 YWIN0	0x03	RW	Bit[7:3]: Reserved Bit[1:0]: win16_ywindow0[9:8] High byte of first horizontal window for 16-window function

table 7-20 window control registers (sheet 5 of 5)

address	register name	default value	R/W	description
0x5A29	WIN16 YWIN0	0x20	RW	Bit[7:0]: win16_ywindow0[7:0] Low byte of first horizontal window for 16-window function
0x5A2A	WIN16 YWIN1	0x02	RW	Bit[7:3]: Reserved Bit[1:0]: win16_ywindow1[9:8] High byte of first horizontal window for 16-window function
0x5A2B	WIN16 YWIN1	0xD0	RW	Bit[7:0]: win16_ywindow1[7:0] Low byte of first horizontal window for 16-window function
0x5A2C	WIN16 YWIN2	0x01	RW	Bit[7:3]: Reserved Bit[1:0]: win16_ywindow2[9:8] High byte of first horizontal window for 16-window function
0x5A2D	WIN16 YWIN2	0x68	RW	Bit[7:0]: win16_ywindow2[7:0] Low byte of first horizontal window for 16-window function
0x5A2E	WIN16 YWIN3	0x00	RW	Bit[7:3]: Reserved Bit[1:0]: win16_ywindow3[9:8] High byte of first horizontal window for 16-window function
0x5A2F	WIN16 YWIN3	0xB4	RW	Bit[7:0]: win16_ywindow3[7:0] Low byte of first horizontal window for 16-window function

OV9281

b&w CMOS 1 megapixel (1280 x 800) image sensor with OmniPixel3-GS™ technology

Confidential for
honeywell-suzhou

8 operating specifications

8.1 absolute maximum ratings

table 8-1 absolute maximum ratings

parameter	absolute maximum rating ^a
ambient storage temperature	-40°C to +125°C
supply voltage (with respect to ground)	V_{DD-A} 4.5V
	V_{DD-D} 3V
	V_{DD-IO} 4.5V
electro-static discharge (ESD)	human body model 2000V
	machine model 200V
all input/output voltages (with respect to ground)	-0.3V to $V_{DD-IO} + 1V$
I/O current on any input or output pin	± 200 mA
peak solder temperature (10 second dwell time)	245°C

- a. exceeding the absolute maximum ratings shown above invalidates all AC and DC electrical specifications and may result in permanent damage to the device. Exposure to absolute maximum rated conditions for extended periods may affect device reliability.

8.2 functional temperature

table 8-2 functional temperature

parameter	range
operating temperature ^a	-30°C to +85°C junction temperature
stable image temperature ^b	0°C to 50°C junction temperature

- a. sensor functions but image quality may be noticeably different at temperatures outside of stable image range
 b. image quality remains stable throughout this temperature range

8.3 DC characteristics

table 8-3 DC characteristics ($T_A = 23^\circ\text{C} \pm 2^\circ\text{C}$)

symbol	parameter	min	typ	max	unit
supply					
V_{DD-A}	supply voltage (analog)	2.6	2.8	3.0	V
V_{DD-IO}	supply voltage (digital I/O)	1.7	1.8	3.0	V
V_{DD-D}	supply voltage (digital core)	1.14	1.2	1.26	V
I_{DD-A}	active (operating) current ^a	TBD	TBD	TBD	mA
I_{DD-IO}		TBD	TBD	TBD	mA
$I_{DDS-SCCB}^b$	standby current	TBD	TBD	TBD	mA
$I_{DDS-SCCB}$		TBD	TBD	TBD	μA
$I_{DDS-XSHUTDOWN}$		TBD	TBD	TBD	μA
digital inputs (typical conditions: AVDD = 2.8V, DVDD = 1.5V, DOVDD = 1.8V)					
V_{IL}	input voltage LOW			0.54	V
V_{IH}	input voltage HIGH	1.26			V
C_{IN}	input capacitor			10	pF
digital outputs (standard loading 25 pF)					
V_{OH}	output voltage HIGH	1.62			V
V_{OL}	output voltage LOW			0.18	V
serial interface inputs					
V_{IL}^c	SIOC and SIOD	-0.5	0	0.54	V
V_{IH}	SIOC and SIOD	1.28	1.8	3.0	V

a. 1280x800 @ 120fps

b. with XVCLK

c. based on DOVDD = 1.8V

8.4 timing characteristics

table 8-4 timing characteristics

symbol	parameter	min	typ	max	unit
oscillator and clock input					
f_{osc}	frequency (XVCLK)	6	24	27	MHz
t_r, t_f	clock input rise/fall time			5 (10 ^a)	ns

a. if using internal PLL

OV9281

b&w CMOS 1 megapixel (1280 x 800) image sensor with OmniPixel3-GS™ technology

Confidential for
honeywell-suzhou

9 mechanical specifications

9.1 physical specifications

figure 9-1 package specifications

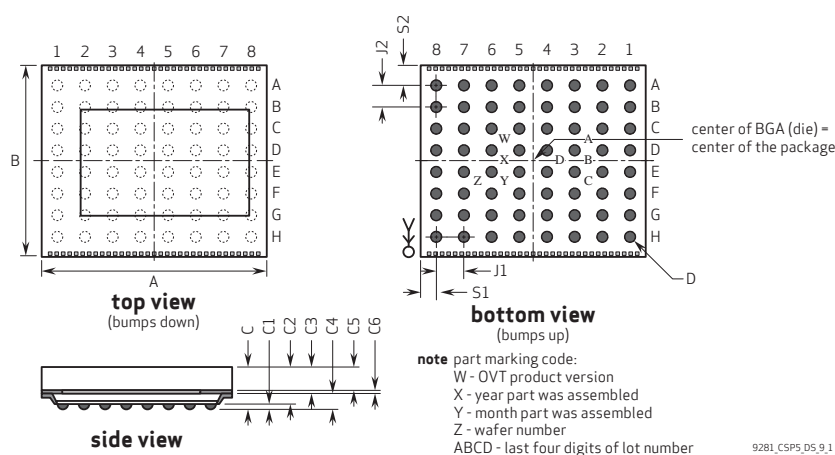

table 9-1 package dimensions

parameter	symbol	min	typ	max	unit
package body dimension x	A	5207	5232	5257	μm
package body dimension y	B	4433	4458	4483	μm
package height	C	680	740	800	μm
ball height	C1	100	130	160	μm
package body thickness	C2	575	610	645	μm
thickness from top glass surface to wafer	C3	425	445	465	μm
image plane height	C4	250	295	340	μm
glass thickness	C5	385	400	415	μm
air gap between sensor and glass	C6	41	45	49	μm
ball diameter	D	220	250	280	μm
total ball count	N		64 (4 NC)		
pins pitch x-axis	J1		640		μm
pins pitch y-axis	J2		500		μm
edge-to-pin center distance along x	S1	346	376	406	μm
edge-to-pin center distance along y	S2	449	479	509	μm

9.2 IR reflow specifications

figure 9-2 IR reflow ramp rate requirements

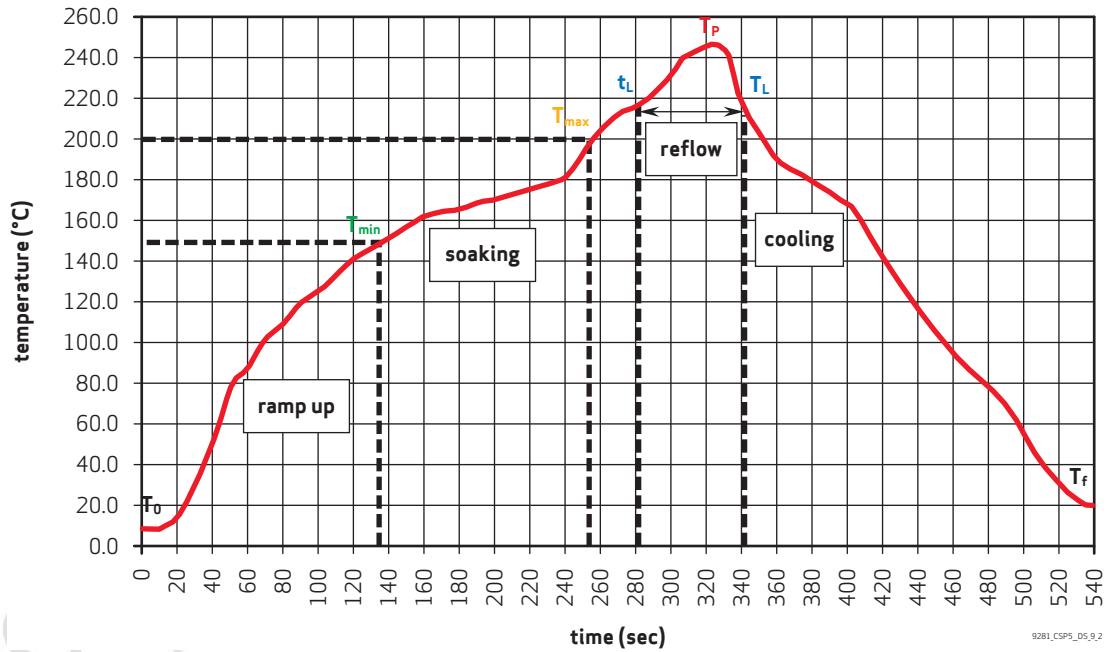

table 9-2 reflow conditions^{ab}

zone	description	exposure
ramp up A (T_0 to T_{min})	heating from room temperature to 150°C	temperature slope $\leq 3^\circ\text{C}$ per second
soaking	heating from 150°C to 200°C	90 ~ 150 seconds
ramp up B (t_L to T_p)	heating from 217°C to 245°C	temperature slope $\leq 3^\circ\text{C}$ per second
peak temperature	maximum temperature in SMT	245°C +0/-5°C (duration max 30 sec)
reflow (t_L to T_L)	temperature higher than 217°C	30 ~ 120 seconds
ramp down A (T_p to T_L)	cooling from 245°C to 217°C	temperature slope $\leq 3^\circ\text{C}$ per second
ramp down B (T_L to T_f)	cooling from 217°C to room temperature	temperature slope $\leq 2^\circ\text{C}$ per second
T_0 to T_p	room temperature to peak temperature	≤ 8 minutes

- a. maximum number of reflow cycles = 3
- b. N2 gas reflow or control O2 gas PPM<500 as recommended



note

The OV9281 uses a lead free package.



OmniVision recommends aCSP packages use underfill as a part of camera assembly process

10 optical specifications

10.1 sensor array center

figure 10-1 sensor array center

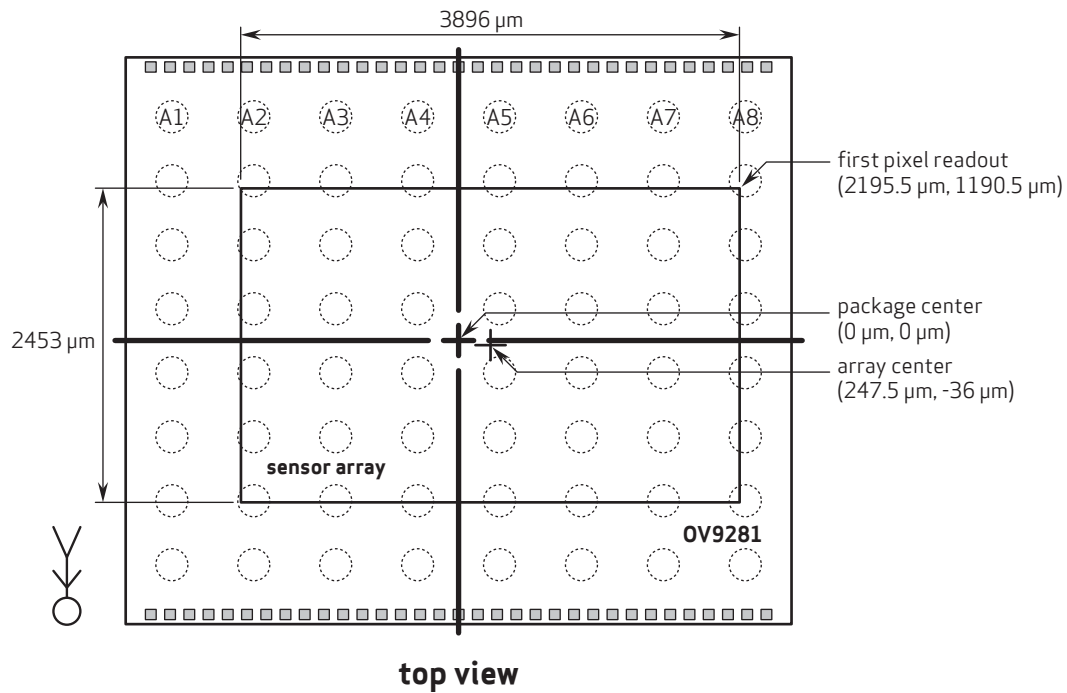

note 1 this drawing is not to scale and is for reference only.

note 2 as most optical assemblies invert and mirror the image, the chip is typically mounted with pins A1 to A8 oriented down on the PCB.

9281_CSP5_DS_10.1

10.2 lens chief ray angle (CRA)

figure 10-2 chief ray angle (CRA)

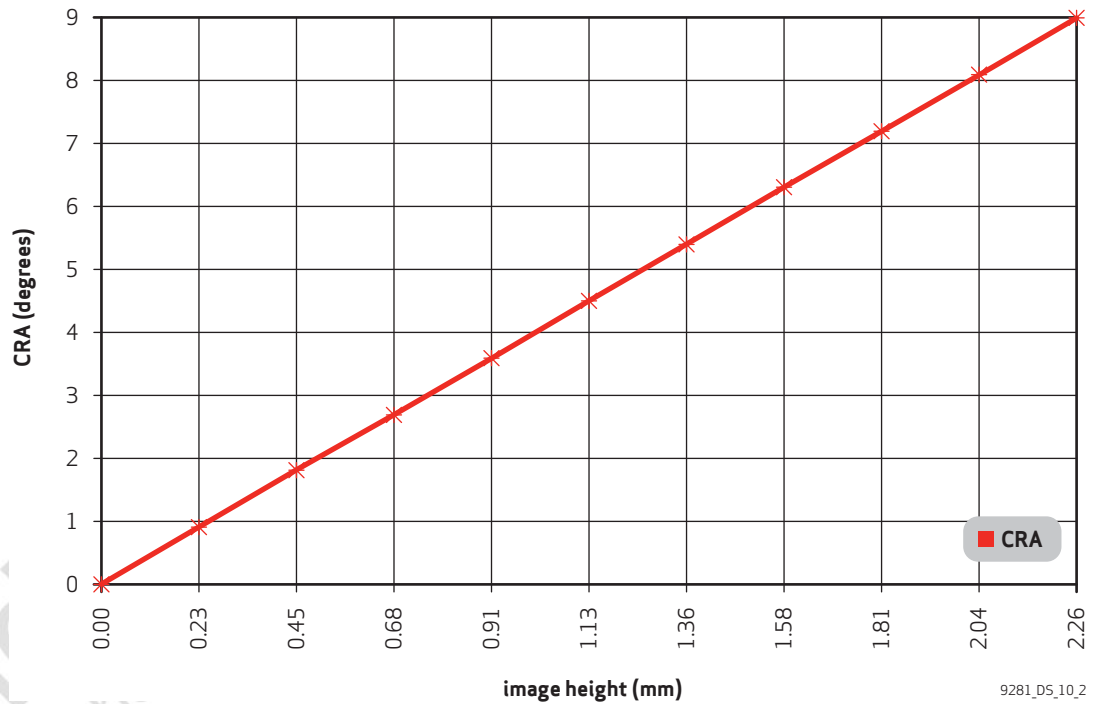

table 10-1 CRA versus image height plot

field (%)	image height (mm)	CRA (degrees)
0.00	0.00	0.00
0.10	0.23	0.90
0.20	0.45	1.80
0.30	0.68	2.70
0.40	0.91	3.60
0.50	1.13	4.50
0.60	1.36	5.40
0.70	1.58	6.30
0.80	1.81	7.20
0.90	2.04	8.10
1.00	2.26	9.00

10.3 IR cut off wavelength

Wavelength above 975nm must be cut off for both monochrome and color sensors to avoid package structure ghosting.
For color sensors, it is recommended to cut wavelength at 650nm or shorter for good color reproduction.

Confidential for
honeywell-suzhou

OV9281

b&w CMOS 1 megapixel (1280 x 800) image sensor with OmniPixel3-GS™ technology

Confidential for
honeywell-suzhou

revision history

version 1.0 07.21.2015

- initial release

version 1.01 09.18.2015

- in chapter 2, updated figure 2-2

Confidential for
honeywell-suzhou

Confidential for
honeywell-suzhou

defining the future of digital imaging™

OmniVision Technologies, Inc.

UNITED STATES

4275 Burton Drive
Santa Clara, CA 95054

tel: +1 408 567 3000
fax: +1 408 567 3001
email: sales@ovt.com

UNITED KINGDOM

Hook, Hampshire +44 1256 744 610

GERMANY

Munich +49 89 63 81 99 88

INDIA

Bangalore +91 80 4112 8966

CHINA

Beijing + 86 10 6580 1690
Shanghai + 86 21 6175 9888
+86 21 5774 9288
Shenzhen + 86 755 8384 9733

JAPAN

Yokohama +81 45 478 7977
Osaka +81 6 4964 2606

KOREA

Seoul + 82 2 3472 3769

SINGAPORE +65 6933 1933

TAIWAN

Taipei +886 2 2657 9800
Hsin-chu +886 3 5656688