

**datasheet**

PRELIMINARY SPECIFICATION

1/2.7" 1080p/720p HD color CMOS image sensor  
with OmniPixel3-HS™ technology

OV2710



## Copyright © 2009 OmniVision Technologies, Inc. All rights reserved.

This document is provided "as is" with no warranties whatsoever, including any warranty of merchantability, non-infringement, fitness for any particular purpose, or any warranty otherwise arising out of any proposal, specification, or sample.

OmniVision Technologies, Inc. and all its affiliates disclaim all liability, including liability for infringement of any proprietary rights, relating to the use of information in this document. No license, expressed or implied, by estoppel or otherwise, to any intellectual property rights is granted herein.

The information contained in this document is considered proprietary to OmniVision Technologies, Inc. and all its affiliates. This information may be distributed to individuals or organizations authorized by OmniVision Technologies, Inc. to receive said information. Individuals and/or organizations are not allowed to re-distribute said information.

### Trademark Information

OmniVision and the OmniVision logo are registered trademarks of OmniVision Technologies, Inc. OmniPixel3-HS is a trademark of OmniVision Technologies, Inc.

All other trademarks used herein are the property of their respective owners.

### **1080p/720p HD color CMOS image sensor with OmniPixel3-HS™ technology**

datasheet (CSP3)  
PRELIMINARY SPECIFICATION

version 1.1  
november 2009

To learn more about OmniVision Technologies, visit [www.ovt.com](http://www.ovt.com).  
OmniVision Technologies is publicly traded on NASDAQ under the symbol OVTI.

OV2710

1080p/720p HD color CMOS image sensor with OmniPixel3-HS™ technology

Confidential for Zoran Digital Technologies (Shenzhen) Limited Only

## applications

- notebook computers
- high-end video conferencing
- security

## ordering information

- **OV02710-A68A** (color, lead-free)  
68-pin CSP3

## features

- programmable controls: gain, exposure, frame rate, image size, horizontal mirror, vertical flip, cropping, windowing, and panning
- automatic image control functions: automatic exposure (AEC), automatic gain control (AGC), automatic white balance (AWB) and automatic black level calibration (ABLC)
- serial camera control bus (SCCB)
- lens correction (LENC)
- defective pixel correction (DPC)
- digital video port (DVP) parallel output interface
- integrated auto focus filter
- support for digital video port (DVP)
- support for one lane MIPI interface (up to 800 Mbps)
- support for output formats: 8-/10-bit RAW RGB
- support for image sizes: 1080p @ 30 fps, cropped 720p @ 60 fps, and VGA @ 60 fps
- support for black sun cancellation
- embedded one-time programmable (OTP) memory
- on-chip phase lock loop (PLL)
- built-in 1.5V regulator for core

## key specifications

- **active array size:** 1920x1080
- **power supply:**  
analog: 3.0~3.6V (3.3V typical)  
core: 1.425~1.575V (1.5V typical)  
I/O: 1.7~3.6V (1.8V typical)
- **power requirements:** TBD  
active: 350 mW  
power down: 70  $\mu$ A
- **temperature range:**  
operating: -30°C to 70°C (see [table 8-2](#))  
stable image: 0°C to 50°C (see [table 8-2](#))
- **output interfaces:** 10-bit parallel / one-lane MIPI
- **output formats:** RAW RGB (10-bit)
- **lens size:** 1/2.7"
- **lens chief ray angle:** 23.6° (see [figure 10-2](#))
- **input clock frequency:** 6 ~ 27 MHz
- **scan mode:** progressive
- **maximum image transfer rate:**  
1080p: 30 fps  
cropped 720p: 60 fps  
VGA: 120 fps  
QVGA: 240 fps
- **sensitivity:** 3300 mV/(Lux-sec)
- **shutter:** rolling
- **S/N ratio:** 39 dB
- **dynamic range:** 69 dB
- **maximum exposure interval:** 1096 tline
- **pixel size:** 3  $\mu$ m x 3  $\mu$ m
- **dark current:** 10 mV/sec @ 60°C
- **well capacity:** 13 Ke<sup>-</sup>
- **fixed pattern noise (FPN):** 1% of V<sub>PEAK-TO-PEAK</sub>
- **image area:** 5856  $\mu$ m x 3276  $\mu$ m
- **package dimensions:** 7465  $\mu$ m x 5865  $\mu$ m

Confidential for Zoran Digital Technologies (Shenzhen) Limited Only

## table of contents

<b>1 signal descriptions</b>	<b>1-1</b>
<b>2 system level description</b>	<b>2-1</b>
2.1 overview	2-1
2.2 architecture	2-1
2.3 format and frame rate	2-6
2.4 I/O control	2-6
2.5 SCCB interface	2-8
2.6 MIPI interface	2-9
2.7 external components	2-9
2.8 power up sequence	2-10
2.8.1 power up with internal DVDD	2-10
2.8.2 power up with external DVDD source	2-11
2.9 power management	2-12
2.10 power ON reset generation	2-12
2.11 system clock control	2-12
<b>3 block level description</b>	<b>3-1</b>
3.1 pixel array structure	3-1
3.2 binning	3-2
<b>4 image sensor core digital functions</b>	<b>4-1</b>
4.1 mirror and flip	4-1
4.2 image windowing	4-2
4.3 test pattern	4-3
4.4 AEC/AGC algorithm	4-3
4.4.1 overview	4-3
4.4.2 AEC algorithm	4-4
4.5 AEC/AGC steps	4-6
4.5.1 auto exposure control (AEC)	4-6
4.5.2 manual exposure control	4-7
4.5.3 auto gain control (AGC)	4-7
4.5.4 manual gain control	4-7
4.6 black level calibration (BLC)	4-8
<b>5 image sensor processor digital functions</b>	<b>5-1</b>
5.1 system control	5-1

<b>6 image sensor output interface digital functions</b>	<b>6-1</b>
6.1 digital video port (DVP)	6-1
6.1.1 overview	6-1
6.2 mobile industry processor interface (MIPI)	6-1
<b>7 register tables</b>	<b>7-1</b>
<b>8 operating specifications</b>	<b>8-1</b>
8.1 absolute maximum ratings	8-1
8.2 functional temperature	8-1
8.3 DC characteristics	8-2
8.4 AC characteristics	8-3
<b>9 mechanical specifications</b>	<b>9-1</b>
9.1 physical specifications	9-1
9.2 IR reflow specifications	9-2
<b>10 optical specifications</b>	<b>10-1</b>
10.1 sensor array center	10-1
10.2 lens chief ray angle (CRA)	10-2



## list of figures

figure 1-1	pin diagram	1-3
figure 2-1	OV2710 block diagram	2-2
figure 2-2	reference design schematic	2-3
figure 2-3	CSP3 flex module schematic	2-4
figure 2-4	CSP3 flex with MIPI schematic	2-5
figure 2-5	power up timing with internal DVDD	2-10
figure 2-6	power up timing with external DVDD source	2-11
figure 3-1	sensor array region color filter layout	3-1
figure 3-2	example of 2x2 binning	3-2
figure 4-1	mirror and flip samples	4-1
figure 4-2	image windowing	4-2
figure 4-3	test pattern	4-3
figure 4-4	desired convergence	4-5
figure 9-1	package specifications	9-1
figure 9-2	IR reflow ramp rate requirements	9-2
figure 10-1	sensor array center	10-1
figure 10-2	chief ray angle (CRA)	10-2

OV2710

1080p/720p HD color CMOS image sensor with OmniPixel3-HS™ technology

Confidential for Zoran Digital Technologies (Shenzhen) Limited Only

## list of tables

table 1-1	signal descriptions	1-1
table 2-1	formats and frame rates	2-6
table 2-2	driving capability and direction control for I/O pads	2-6
table 2-3	group sharing registers	2-8
table 2-4	group write register	2-8
table 3-1	binning-related registers	3-2
table 4-1	mirror and flip registers	4-1
table 4-2	image cropping control functions	4-2
table 4-3	test pattern selection control	4-3
table 4-4	AEC/AGC control functions	4-4
table 4-5	AEC control functions	4-5
table 4-6	BLC control functions	4-8
table 5-1	system control registers	5-1
table 6-1	DVP control registers	6-1
table 7-1	SC control registers	7-1
table 7-2	SCCB control registers	7-4
table 7-3	group sharing registers	7-4
table 7-4	analog registers	7-5
table 7-5	timing control registers	7-5
table 7-6	AEC/AGC registers	7-6
table 7-7	OTP registers	7-9
table 7-8	BLC registers	7-11
table 7-9	FC control registers	7-12
table 7-10	DVP registers	7-12
table 7-11	MIPI registers	7-13
table 7-12	ISP control registers	7-17
table 7-13	AWB control registers	7-19
table 7-14	AVG registers	7-21
table 7-15	DPC registers	7-22
table 7-16	LENC registers	7-24
table 7-17	AFC registers	7-27
table 8-1	absolute maximum ratings	8-1

table 8-2	functional temperature	8-1
table 8-3	DC characteristics (-30°C < TA < 70°C)	8-2
table 8-4	AC characteristics (TA = 25°C, VDD-A = 2.8V)	8-3
table 8-5	timing characteristics	8-3
table 9-1	package dimensions	9-1
table 9-2	reflow conditions	9-2
table 10-1	CRA versus image height plot	10-2

Confidential for Zoran Digital Technologies (Shenzhen) Limited Only

# 1 signal descriptions

**table 1-1** lists the signal descriptions and their corresponding pin numbers for the OV2710 image sensor. The package information is shown in **section 9**.

**table 1-1** signal descriptions (sheet 1 of 3)

pin number	signal name	pin type	description
A1	NC	–	no connect
A2	NC	–	no connect
A3	NC	–	no connect
A4	NC	–	no connect
A5	SVDD	power	power for sensor circuit
A6	SGND	ground	ground for sensor circuit
A7	SVDD	power	power for sensor circuit
A8	RESETB	input	reset (active low with internal pull up resistor)
A9	DOGND	ground	ground for I/O circuit
A10	VHT	reference	internal analog reference
A11	VN	reference	internal analog reference
B1	AVDD	power	power for analog circuit
B2	NC	–	no connect
B3	NC	–	no connect
B4	NC	–	no connect
B5	NC	–	no connect
B6	SGND	ground	ground for sensor circuit
B7	TM <sup>a</sup>	input	test mode (active high with internal pull down resistor)
B8	PWDN	input	power down (active high with internal pull down resistor)
B9	DOVDD	power	power for I/O circuit
B10	VH	reference	internal analog reference
B11	AVDD	power	power for analog circuit
C1	AGND	ground	ground for analog circuit
C2	NC	–	no connect
C10	NC	–	no connect
C11	AGND	ground	ground for analog circuit

table 1-1 signal descriptions (sheet 2 of 3)

pin number	signal name	pin type	description
D1	AVDD	power	power for analog circuit
D2	NC	–	no connect
D10	NC	–	no connect
D11	AGND	ground	ground for analog circuit
E1	NC	–	no connect
E2	NC	–	no connect
E10	NC	–	no connect
E11	AVDD	power	power for analog circuit
F1	NC	–	no connect
F2	NC	–	no connect
F10	NC	–	no connect
F11	NC	–	no connect
G1	DGND	ground	ground for digital circuit
G2	XVCLK	input	system input clock
G3	NC	–	no connect
G4	EVDD	power	power for MIPI
G5	D3	I/O	DVP data output 3
G6	DOVDD	power	power for I/O circuit
G7	NC	–	no connect
G8	NC	–	no connect
G9	SIOC	input	SCCB input clock
G10	DGND	ground	ground for digital circuit
G11	NC	–	no connect
H1	PVDD	power	power for PLL circuit
H2	VSYNC	I/O	DVP VSYNC output/ MIPI TX clock lane positive output
H3	HREF	I/O	DVP HREF output/ MIPI TX clock lane negative output
H4	D9	I/O	DVP data output 9 (MSB)/MIPI TX data lane positive output
H5	D7	I/O	DVP data output 7/MIPI TX data lane negative output
H6	DOVDD	power	power for I/O circuit
H7	DOGND	ground	ground for I/O circuit

table 1-1 signal descriptions (sheet 3 of 3)

pin number	signal name	pin type	description
H8	D2	I/O	DVP data output 2 (LSB for 8-bit mode)
H9	D6	I/O	DVP data output 6
H10	SIOD	I/O	SCCB data
H11	DVDD	power	power for digital circuit
I1	PVDD	power	power for PLL circuit
I3	EGND	ground	ground for MIPI
I5	D5	I/O	DVP data output 5
I6	D1	I/O	DVP data output 1
I7	PCLK	I/O	DVP PCLK output
I8	D0	I/O	DVP data output 0 (LSB for 10-bit mode)
I9	D4	I/O	DVP data output 4
I10	D8	I/O	DVP data output 8

a. should be connected to DOGND

figure 1-1 pin diagram

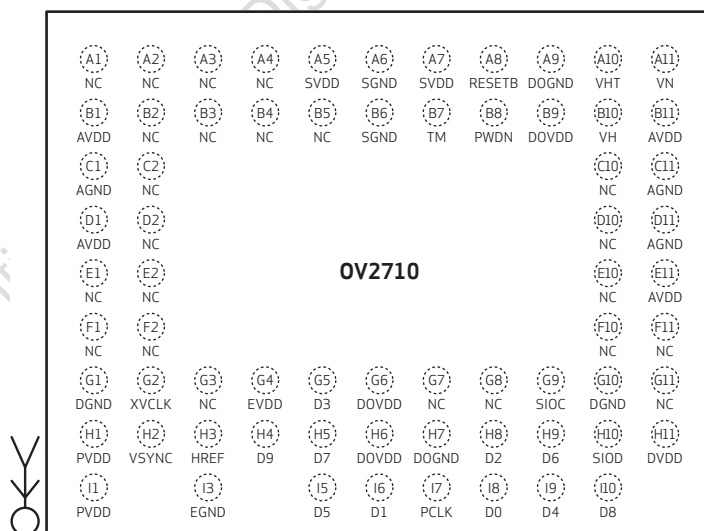

2710\_CSP\_D5\_1.1

OV2710

1080p/720p HD color CMOS image sensor with OmniPixel3-HS™ technology

Confidential for Zoran Digital Technologies (Shenzhen) Limited Only



## 2 system level description

### 2.1 overview

The OV2710 (color) image sensor is a low voltage, high performance 1/2.7-inch full size HD CMOS image sensor that provides the full functionality of a single 1080p (1920x1080) camera using OmniPixel3-HS™ technology in a small footprint package. It provides full-frame, sub-sampled and windowed 10-bit images in various formats via the control of the Serial Camera Control Bus (SCCB) interface or MIPI interface.

The OV2710 has an image array capable of operating at up to 30 frames per second (fps) in 1080P resolution with complete user control over image quality, formatting and output data transfer. All required image processing functions, including exposure control, white balance, defective pixel canceling, lens shading correction etc., are programmable through the SCCB interface. In addition, Omnivision image sensors use proprietary sensor technology to improve image quality by reducing or eliminating common lighting/electrical sources of image contamination, such as fixed pattern noise, smearing, etc., to produce a clean, fully stable, color image.

For customized information purposes, the OV2710 includes a one-time programmable (OTP) memory.

The OV2710 has a one lane MIPI interface and a traditional parallel digital video port (DVP).

### 2.2 architecture

The OV2710 sensor core generates stream pixel data at a constant frame rate, indicated by HREF, VSYNC, and PCLK. **figure 2-1** shows the functional block diagram of the OV2710 image sensor.

The timing generator outputs signals to access the rows of the image array, precharging and sampling the rows of array in series. In the time between pre-charging and sampling a row, the charge in the pixels decreases with the time exposed to the incident light. This is known as exposure time.

The exposure time is controlled by adjusting the time interval between precharging and sampling. After the data of the pixels in the row has been sampled, it is processed through analog circuitry to correct the offset and multiply the data with corresponding gain. Following analog processing is the ADC which outputs 10-bit data for each pixel in the array.

figure 2-1 OV2710 block diagram

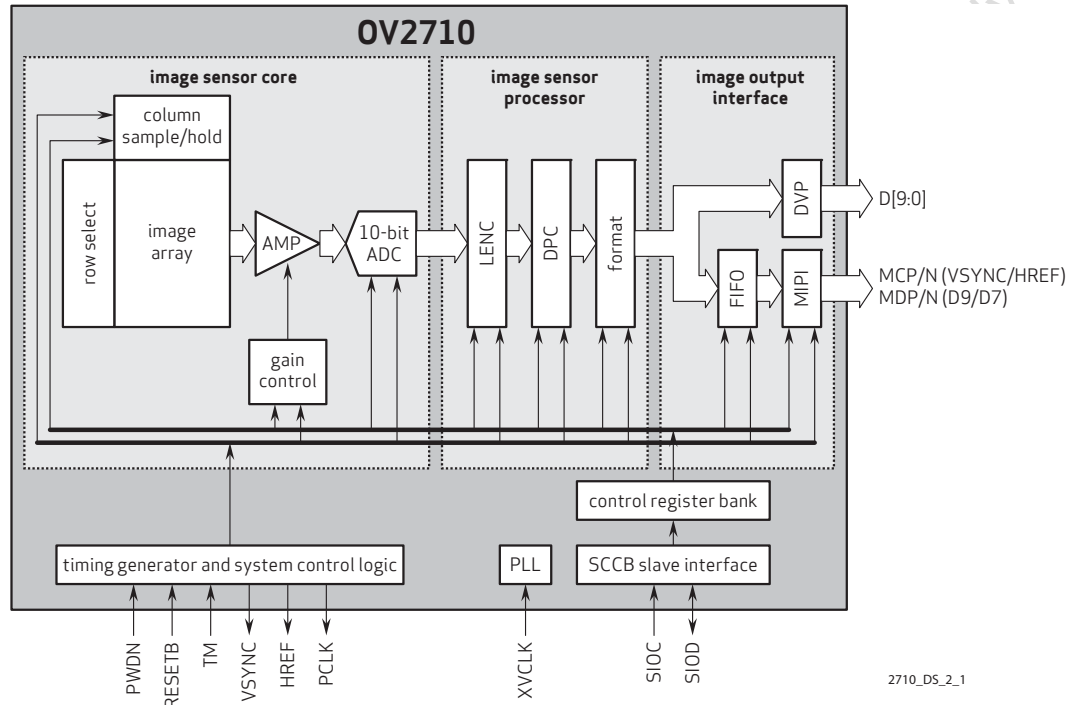

2710\_DS\_2\_1

Confidential for Zoran Digital

figure 2-2 reference design schematic

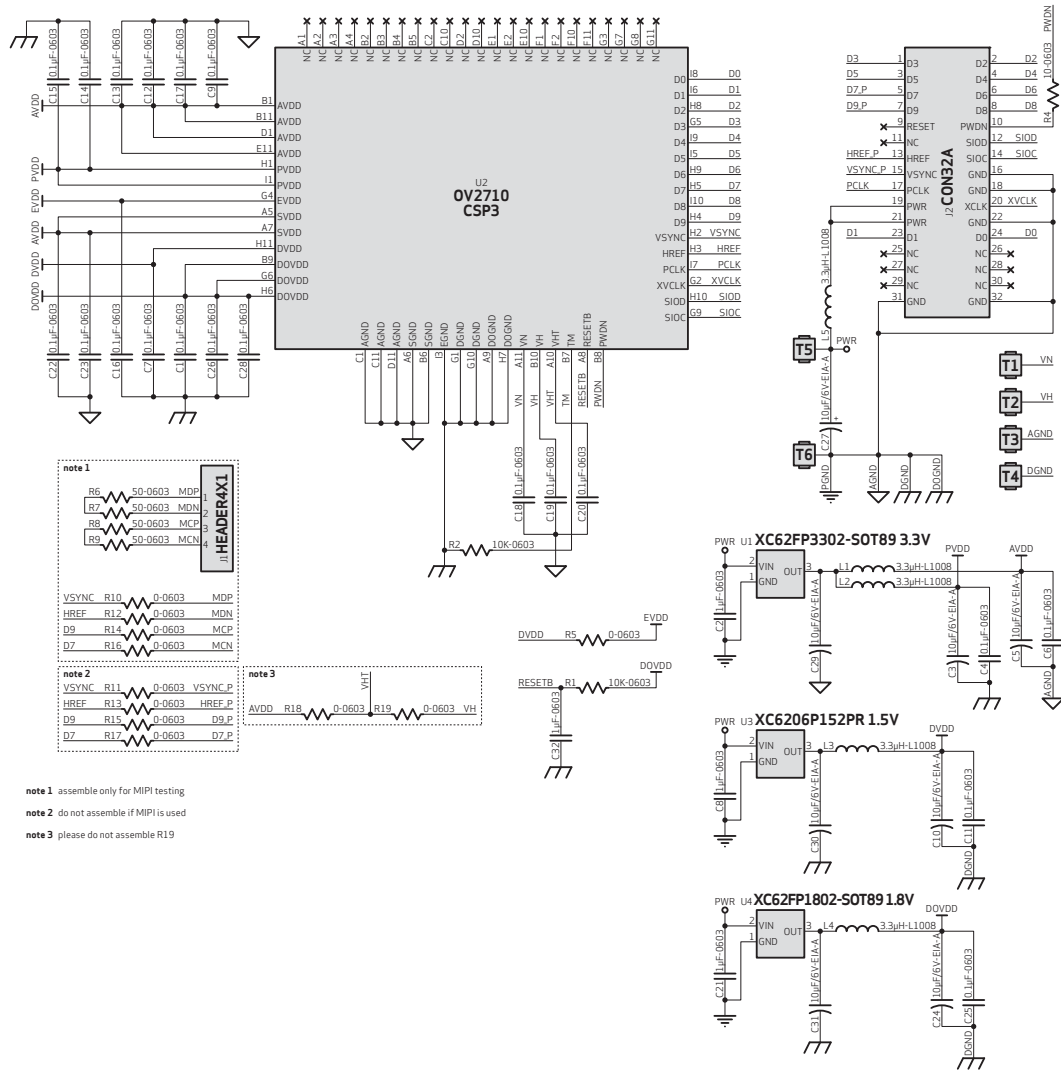

**note 1**

R6	50-0603	MDP
R7	50-0603	MDN
R8	50-0603	MCP
R9	50-0603	MCN

**note 2**

VSYNC	R10	0-0603	MDP
HREF	R12	0-0603	MDN
D9	R14	0-0603	MCP
D7	R16	0-0603	MCN

**note 3**

VHT	R19	0-0603	VH
-----	-----	--------	----

**note 1** assemble only for MIPI testing  
**note 2** do not assemble if MIPI is used  
**note 3** please do not assemble R19

2710\_S\_DS\_2.2

figure 2-3 CSP3 flex module schematic

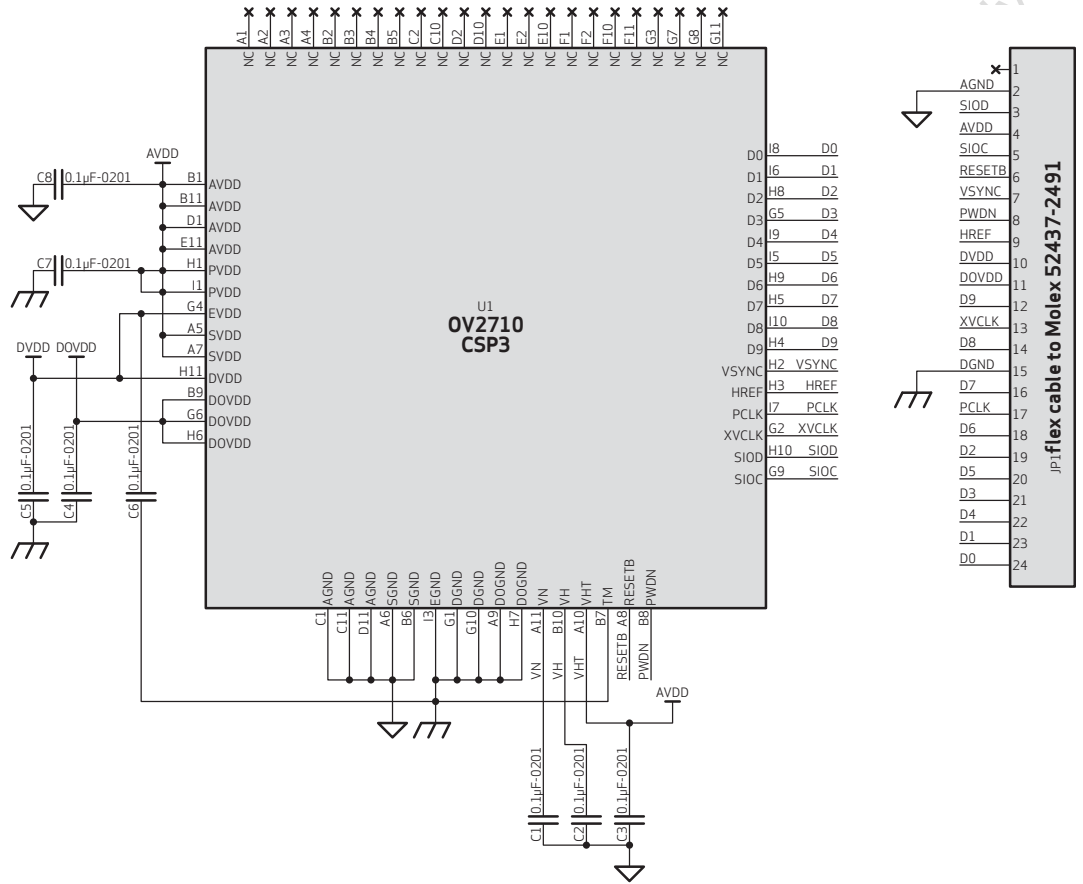

- note 1** PWDN should be connected to ground outside of module if unused.
- note 2** RESETB should be connected to DOVDD outside of module if unused.
- note 3** AVDD is 3.0-3.6V of sensor analog power (clean). 3.3V is typical.
- note 4** DOVDD is 1.7-3.6V of sensor digital IO power (clean). 1.8V is typical.
- note 5** DVDD is 1.5V of sensor core power (clean). Internal regulator (no external 1.5V DVDD is needed) is recommended for 1.8V DOVDD. External 1.5V DVDD is recommended for 2.8V DOVDD.
- note 6** sensor AGND and DGND should be separated and connected to a single point outside PCB (do not connect inside module).
- note 7** DGND and EGND should be two separated nets, and only connected at a single point close to pin 39 or 40 of JP1.
- note 8** capacitors should be close to the related sensor pins.
- note 9** if more space available, use cap of 1µF-0402 for C5 between DVDD and DGND.
- note 10** D[9:0] (D9:MSB, D0:LSB) is sensor RGB RAW 10-bit output. D[9:2] (D9:MSB, D2:LSB) is RGB RAW 8-bit output.

2710\_CSP\_DS\_2\_3

figure 2-4 CSP3 flex with MIPI schematic

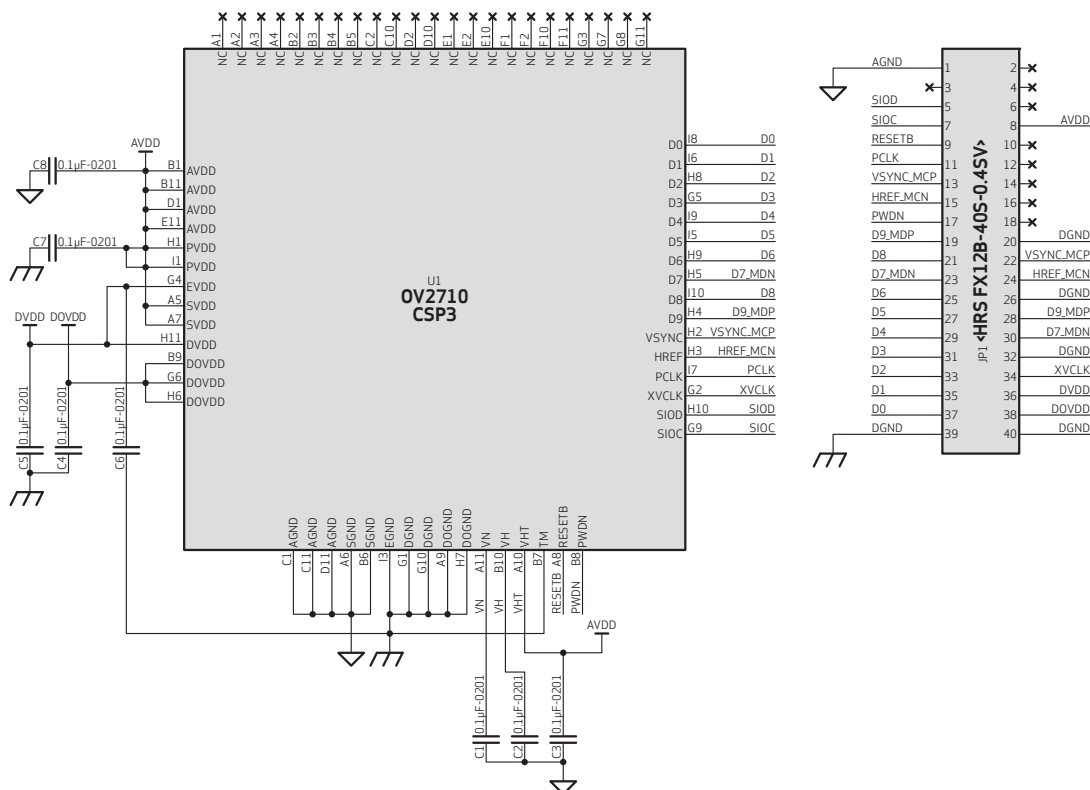

- note 1** PWDN should be connected to ground outside of module if unused.
- note 2** RESETB should be connected to DOVDD outside of module if unused.
- note 3** AVDD is 3.0-3.6V of sensor analog power (clean). 3.3V is typical.
- note 4** DOVDD is 1.7-3.6V of sensor digital IO power (clean). 1.8V is typical.
- note 5** DVDD is 1.5V of sensor core power (clean). Internal regulator (no external 1.5V DVDD is needed) is recommended for 1.8V DOVDD. External 1.5V DVDD is recommended for 2.8V DOVDD.
- note 6** sensor AGND and DGND should be separated and connected to a single point outside PCB (do not connect inside module).
- note 7** DGND and EGND should be two separated nets, and only connected at a single point close to pin 39 or 40 of JP1.
- note 8** capacitors should be close to the related sensor pins.
- note 9** if more space available, use cap of 1µF-0402 for C5 between DVDD and DGND.
- note 10** D[9:0] (D9:MSB, D0:LSB) is sensor RGB RAW 10-bit output. D[9:2] (D9:MSB, D2:LSB) is RGB RAW high 8-bit output.
- note 11** EVDD/EGND are power/ground for MIPI core. In MIPI mode, D9\_MDP and D7\_MDN are MIPI data lane positive and negative output. VSYNC\_MCP and HREF\_MCN are MIPI clock lane positive and negative output.
- note 12** traces of D9\_MDP, D7\_MDN, VSYNC\_MCP and HREF\_MCN should have the same or similar length. impedance transmission lines should be controlled at 100 Ohm.

2710\_CSP\_DS\_2\_4

## 2.3 format and frame rate

The OV2710 supports RAW RGB output with 10-bit DVP and 1-lane MIPI interface.

**table 2-1** formats and frame rates

format	resolution	frame rate	scaling method	pixel clock (RAW)
1080p	1920 x 1080	30 fps	full	80 MHz
720p	1280 x 720	60 fps	cropping	80 MHz
VGA	640 x 480	120 fps	subsampling and cropping	80 MHz
VGA	640 x 480	60 fps	subsampling, binning and cropping	80 MHz
QVGA	320 x 240	240 fps	subsampling and cropping	80 MHz
QVGA	320 x 240	60 fps	subsampling, binning and cropping	80 MHz

## 2.4 I/O control

The OV2710 I/O pad direction and driving capability can be easily adjusted. **table 2-2** lists the driving capability and direction control registers of the I/O pads.

**table 2-2** driving capability and direction control for I/O pads (sheet 1 of 2)

function	register	R/W	description
output drive capability control	0x302C	RW	Bit[7:6]: Output drive capability 00: 1x 01: 2x 10: 3x 11: 4x
D[9:0] I/O control	0x73017[3:0], 0x3018[7:2]	RW	input/output selection for the D[9:0] pins 0: input 1: output
D[9:0] output select	0x301D[3:0], 0x301E[7:2]	RW	output selection for the D[9:0] pins 0: normal data path 1: register-controlled value
D[9:0] output value	0x301A[3:0], 0x301B[7:2]	RW	D[9:0] output value
D[9:0] input value	0x3041[3:0], 0x3042[7:2]	R	D[9:0] input value
VSYNC I/O control	0x3017	RW	Bit[6]: input/output selection for the VSYNC pin 0: input 1: output

**table 2-2** driving capability and direction control for I/O pads (sheet 2 of 2)

function	register	R/W	description
VSYNC output select	0x301D	RW	Bit[6]: output selection for the VSYNC pin 0: normal data path 1: register-controlled value
VSYNC output value	0x301A	RW	Bit[6]: VSYNC output value
VSYNC input value	0x3041	R	Bit[6]: VSYNC input value
HREF I/O control	0x3017	RW	Bit[6]: input/output selection for the HREF pin 0: input 1: output
HREF output select	0x301D	RW	Bit[5]: output selection for the HREF pin 0: normal data path 1: register-controlled value
HREF output value	0x301A	RW	Bit[5]: HREF output value
HREF input value	0x3041	R	Bit[5]: HREF input value
PCLK I/O control	0x3017	RW	Bit[4]: input/output selection for the PCLK pin 0: input 1: output
PCLK output select	0x301D	RW	Bit[4]: output selection for the PCLK pin 0: normal data path 1: register-controlled value
PCLK output value	0x301A	RW	Bit[4]: PCLK output value
PCLK input value	0x3041	R	Bit[4]: PCLK input value
STROBE I/O control	0x3016	RW	Bit[1]: input/output selection for the STROBE pin 0: input 1: output
STROBE output select	0x301C	RW	Bit[1]: Output selection for the STROBE pin 0: normal data path 1: register-controlled value
STROBE output value	0x3019	RW	Bit[1]: STROBE output value
STROBE input value	0x3040	R	Bit[1]: STROBE input value

## 2.5 SCCB interface

The Serial Camera Control Bus (SCCB) interface controls the image sensor operation. Refer to the OmniVision Technologies Serial Camera Control Bus (SCCB) Specification for detailed usage of the serial control port.

Group write is supported in order to update a group of registers in the same frame. These registers are guaranteed to be written prior to the internal latch at the frame boundary.

The OV2710 supports up to four groups. These groups share 1 KB RAM and the size of each group is programmable by adjusting the start address.

**table 2-3** group sharing registers

address	register name	default value	R/W	description
0x3200	GROUP_ADDR0	0x40	RW	Start Address for Group0 {group_addr0[7:0], 4'h0}
0x3201	GROUP_ADDR1	0x4A	RW	Start Address for Group1 {group_addr1[7:0], 4'h0}
0x3202	GROUP_ADDR2	0x54	RW	Start Address for Group2 {group_addr2[7:0], 4'h0}
0x3203	GROUP_ADDR3	0x5E	RW	Start Address for Group3 {group_addr3[7:0], 4'h0}

The group write function is controlled by register **0x3212**.

**table 2-4** group write register

address	register name	default value	R/W	description
0x3212	GROUP_ACCESS	0x00	RW	Bit[7]: group_launch_en Bit[6]: Debug mode (must be 0) Bit[5]: group_launch Bit[4]: group_hold_end Bit[3:0]: group_id 00-11: ID of the group to hold register

The SCCB will enter group write mode after writing to register **0x3212** with a valid group ID. The subsequent registers will be held to the buffer specified by the group\_id instead of writing to the registers. Make sure the number of registers does not exceed the capacity of the group. Setting group\_hold\_end to 1 will exit the group write mode. After that, both group\_launch and group\_launch\_en should be set to 1 in order to write the buffered values to the real registers. Multiple



groups of registers can be prepared before writing to the real registers but be sure the correct group\_id is specified when the group write is launched.

The following is an example demonstrating the group write operation:

```

78 3212 00  Enable group0
78 3600 00  Write registers to be held in group0
78 3601 01
78 3212 10  End group0
78 3212 01  Enable group1
78 3602 02  Write registers to be held in group1
78 3603 03
78 3212 11  End group1

..... Other direct register access

78 3212 02  Enable group2
78 3604 04  Write registers to be held in group2
78 3605 05
78 3212 12  End group2

78 3212 A0  Launch group0

..... Other direct register access

78 3212 03  Enable group3
78 3606 06  Write registers to be held in group3
78 3607 07
78 3212 13  End group3

78 3212 A1  Launch group1
78 3212 A2  Launch group2
78 3212 A3  Launch group3

```

## 2.6 MIPI interface

The OV2710 supports 1-lane MIPI transmitter interface with maximum 800Mbps per lane MIPI interface.

## 2.7 external components

Image sensor analog power is provided from a 3.3V (typical) power circuit coming from the system. An internal regulator provides 1.5V for core logic with I/O power (DOVDD). I/O PAD power supports 1.7 to 3.60V.

## 2.8 power up sequence

Based on the system power configuration, the power up sequence will differ.

### 2.8.1 power up with internal DVDD

When powering up with the internal DVDD and SCCB access during the power ON period, the following conditions must occur:

1. if  $V_{DD-IO}$  and  $V_{DD-A}$  are turned ON at the same time, make sure  $V_{DD-IO}$  becomes stable before  $V_{DD-A}$  becomes stable
2. PWDN is active high with an asynchronized design (does not need clock)
3. PWDN must go high during the power up period
4. for PWDN to go low, power must first become stable ( $AVDD$  to PWDN  $\geq 5$  ms)
5. RESETB is active low with an asynchronized design
6. state of RESETB does not matter during power up period once DOVDD is up
7. master clock XVCLK should provide at least 1 ms before host accesses sensor's I2C
8. host can access I2C bus (if shared) during entire period. 20 ms after PWDN goes low or 20 ms after RESETB goes high if reset is inserted after PWDN goes low, host can access sensor's SCCB to initialize sensor

figure 2-5 power up timing with internal DVDD

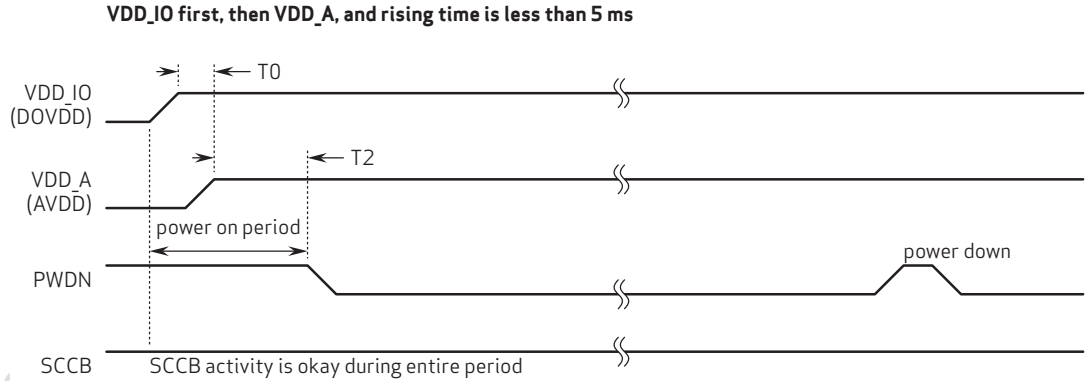

**note**  $T_0 \geq 0$  ms: delay from VDD\_IO stable to VDD\_A stable  
 $T_2 \geq 5$  ms: delay from VDD\_A stable to sensor power up stable

2710\_DS\_2.3

## 2.8.2 power up with external DVDD source

When powering up with an external DVDD source and I2C access during the power ON period, the following conditions must occur:

1. if  $V_{DD-IO}$  and  $V_{DD-A}$  are turned ON at the same time, make sure  $V_{DD-IO}$  becomes stable before  $V_{DD-A}$  becomes stable
2. if  $V_{DD-A}$  and  $V_{DD-D}$  are turned ON at the same time, make sure  $V_{DD-A}$  becomes stable before  $V_{DD-D}$  becomes stable
3. PWDN is active high with an asynchronized design (does not need clock)
4. for PWDN to go low, power must first become stable ( $DVDD$  to PWDN  $\geq 5$  ms)
5. all powers are cut off when the camera is not in use (power down mode is not recommended)
6. RESETB is active low with an asynchronized design
7. state of RESETB does not matter during power up period once DOVDD is up
8. master clock XVCLK should provide at least 1 ms before host accesses sensor's I2C
9. host can access I2C bus (if shared) during entire period. 20 ms after PWDN goes low or 20 ms after RESETB goes high if reset is inserted after PWDN goes high, host can access sensor's I2C to initialize sensor

figure 2-6 power up timing with external DVDD source

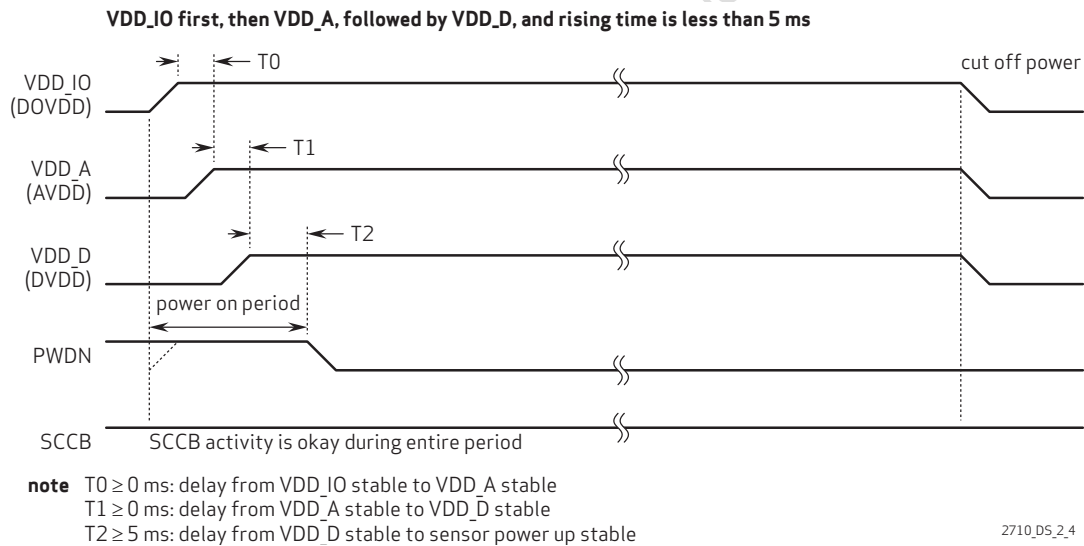

## 2.9 power management

Only system related functions are always powered ON. Sensor and ISP functions are cut off during power down mode. Also, during the power on stage of the whole chip, these functions will power up after system functions power up.

During power down, all registers keep their values. So, during the resume state, all the registers are restored to their original values.

In power down mode, the clock input from the system must be turned off even when the external clock source is still clocking.

## 2.10 power ON reset generation

The power on reset can be controlled by an external pin. However, inside this device, there is a power ON reset generation function to auto detect core power at a stable state.

## 2.11 system clock control

The OV2710 has an on-chip PLL which generates the system clock with a 6~27 MHz input clock. A programmable clock divider is needed to generate different frequencies for the system.

Confidential for Zoran Digital Technologies (Shenzhen) Limited Only

## 3 block level description

### 3.1 pixel array structure

The OV2710 sensor has an image array of 1952 columns by 1092 rows (2,131,584 pixels). **figure 3-1** shows a cross-section of the image sensor array.

The color filters are arranged in a Bayer pattern. The primary color BG/GR array is arranged in line-alternating fashion. Of the 2,131,584 pixels, 2,073,600 (1920x1080) are active pixels and can be output. The other pixels are used for black level calibration and interpolation.

The sensor array design is based on a field integration read-out system with line-by-line transfer and an electronic shutter with a synchronous pixel read-out scheme.

**figure 3-1** sensor array region color filter layout

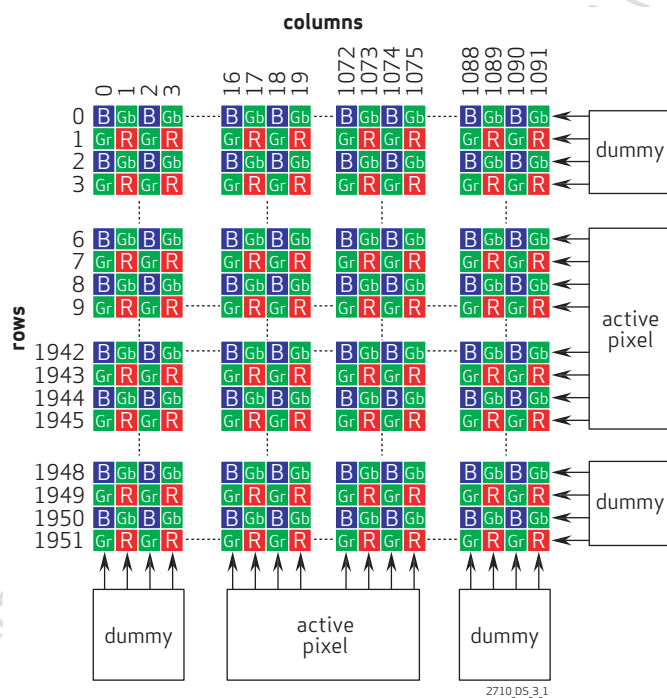

### 3.2 binning

Binning mode is usually used for subsampling. During subsampling, information is periodically dropped when data is output. When the binning function is ON, voltage levels of adjacent pixels are averaged before being sent to the ADC. If the binning function is OFF, the pixels, which are not output, are merely skipped. The OV2710 supports 2x2, and 2x1 binning. **figure 3-2** illustrates 2x2 binning, where the voltage levels of four (2x2) adjacent same-color pixels are averaged before entering the ADC.

**figure 3-2** example of 2x2 binning

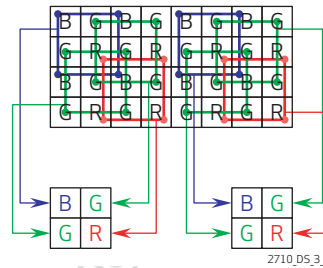

**table 3-1** binning-related registers

address	register name	default value	R/W	description
0x370D	SENSOR REG0D	0x0C	RW	Bit[6]: Vertical binning
0x3621	ANA ARRAY 01	0x10	RW	Array Control Bit[7]: Horizontal binning Bit[6]: Horizontal skip

## 4 image sensor core digital functions

### 4.1 mirror and flip

The OV2710 provides Mirror and Flip readout modes, which respectively reverse the sensor data readout order horizontally and vertically (see [figure 4-1](#)). In flip, the OV2710 does not need additional settings because the ISP block will auto-detect whether the pixel is in the red line or blue line and make the necessary adjustments.

**figure 4-1** mirror and flip samples

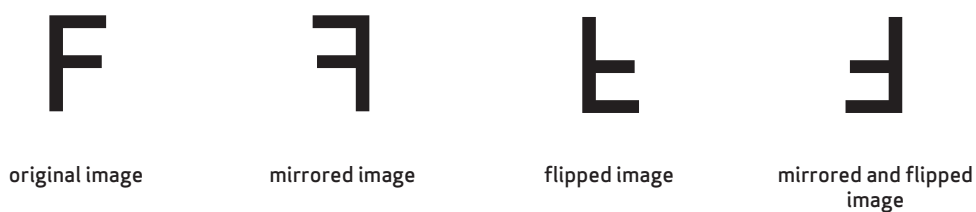

2710 D5 4 1

**table 4-1** mirror and flip registers

address	register name	default value	R/W	description
0x3818	TIMING CONTROL 18	0x80	RW	Bit[6]: Horizontal mirror Bit[5]: Vertical flip

## 4.2 image windowing

An image windowing area is defined by four parameters, horizontal start (HS), horizontal width (HW), vertical start (VS), and vertical height (VH). By properly setting the parameters, any portion within the sense array size can be cropped as a visible area. This cropping is achieved by simply masking the pixels outside the cropping window; thus, it will not affect original timings. It will also not conflict with the flip and mirror functions.

figure 4-2 image windowing

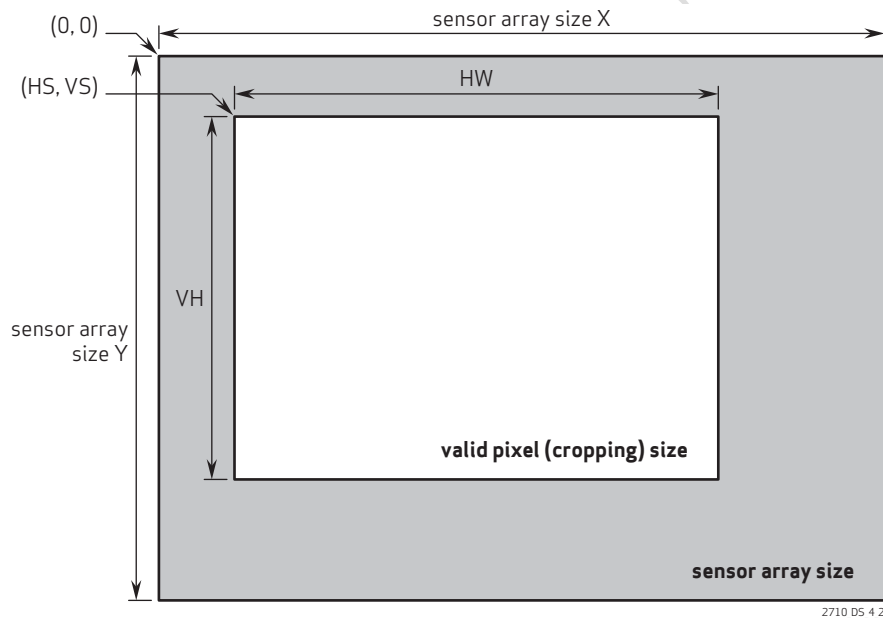

table 4-2 image cropping control functions

function	register	description
horizontal start	{0x3800, 0x3801}	HS[11:8] = 0x3800 HS[7:0] = 0x3801
vertical start <sup>a</sup>	{0x3802, 0x3803}	VS[11:8] = 0x3802 VS[7:0] = 0x3803
horizontal width	{0x3804, 0x3805}	HW[11:8] = 0x3804 HW[7:0] = 0x3805
vertical height	{0x3806, 0x3807}	VH[11:8] = 0x3806 VH[7:0] = 0x3807

a. VS can only be an even number



## 4.3 test pattern

For testing purposes, the OV2710 offers one type of test pattern, color bar.

**figure 4-3** test pattern

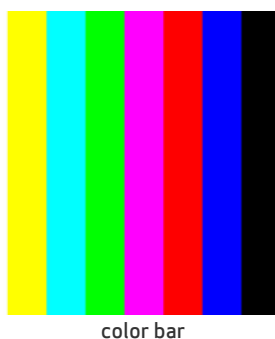

**table 4-3** test pattern selection control

function	register	description
color bar	0x503D	Bit[7]: Color bar enable 0: Color bar OFF 1: Color bar enable
	0x503D	Bit[5:4]: Color bar pattern select 10: Color bar pattern

## 4.4 AEC/AGC algorithm

### 4.4.1 overview

The Auto Exposure Control (AEC) and Auto Gain Control (AGC) allows the image sensor to adjust the image brightness to a desired range by setting the proper exposure time and gain applied to the image. Besides automatic control, exposure time and gain can be set manually from external control. The related registers are listed in **table 4-4**

table 4-4 AEC/AGC control functions

address	register name	default value	R/W	description
0x3500	AEC EXPO	0x00	RW	AEC Exposure Bit[7:4]: Not used Bit[3:0]: Exposure[19:16]
0x3501	AEC EXPO	0x00	RW	AEC Exposure Bit[7:0]: Exposure[15:8]
0x3502	AEC EXPO	0x00	RW	AEC Exposure Bit[7:0]: Exposure[7:0]
0x3503	AEC MANUAL	0x00	RW	AEC Manual Mode Control Bit[7:2]: Not used Bit[1]: AGC manual enable 0: Auto enable 1: Manual enable Bit[0]: AEC manual enable 0: Auto enable 1: Manual enable
0x350A	AEC AGC ADJ	0x00	RW	Gain Output to Sensor Bit[0]: Gain high bit  Gain = (0x350A[0]+1) × (0x350B[7]+1) × (0x350B[6]+1) × (0x350B[5]+1) × (0x350B[4]+1) × (0x350B[3:0]/16+1)
0x350B	AEC AGC ADJ	0x00	RW	Gain Output to Sensor Bit[7:0]: Gain low bits  Gain = (0x350A[0]+1) × (0x350B[7]+1) × (0x350B[6]+1) × (0x350B[5]+1) × (0x350B[4]+1) × (0x350B[3:0]/16+1)

#### 4.4.2 AEC algorithm

The AEC controls image luminance using registers **AEC CONTROL 0F** (0x3A0F), **AEC CONTROL 10** (0x3A10), **AEC CONTROL 1B** (0x3A1B), and **AEC CONTROL 1E** (0x3A1E). The value of register **AEC CONTROL 0F** (0x3A0F) indicates the high threshold value, and the value of register **AEC CONTROL 10** (0x3A10) indicates the low threshold value. The value of register **AEC CONTROL 1B** (0x3A1B) indicates the high threshold value for image change from stable state to unstable state and the value of register **AEC CONTROL 1E** (0x3A1E) indicates the low threshold value for image change from stable state to unstable state. When the target image luminance average value AVERAGE CTRL10 (0x568A) is within the range specified by registers **AEC CONTROL 1B** (0x3A1B) and **AEC CONTROL 1E** (0x3A1E), the AEC keeps the image exposure and gain. When register **AEC CONTROL 10** (0x568A) is greater than the value in register **AEC CONTROL 1B** (0x3A1B), the AEC will decrease the image exposure and gain until it falls into the range of {**0x3A10**, **0x3A0F**}. When register **AEC CONTROL 10** (0x568A) is less than the value in register **AEC CONTROL 1E** (0x3A1E), the AEC will increase the image exposure and gain until it falls into the range of {**0x3A10**, **0x3A1F**}. Accordingly, the value in register **AEC CONTROL 0F** (0x3A0F) should be greater than the value in register

**AEC CONTROL 10** (0x3A10). The gap between the values of registers **AEC CONTROL 1B** (0x3A1B) and **AEC CONTROL 1E** (0x3A1E) controls the image stability.

As shown in **figure 4-4**, the AEC/AGC convergence uses two regions, the inner stable operating region and the outer control zone, which defines the convergence step size of fast and slow conditions.

**figure 4-4** desired convergence

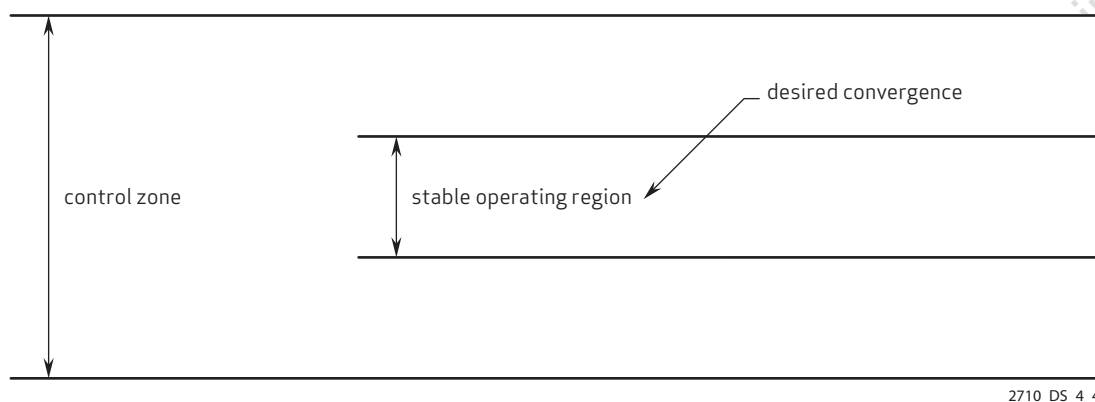

2710\_DS\_4\_4

As for auto mode, the AEC will automatically calculate the steps needed based on the difference between target and current values. So, the outer control zone is meaningless for this mode.

**table 4-5** AEC control functions

address	register name	default value	R/W	description
0x3A0F	AEC CONTROL 0F	0x78	RW	Stable Range High Limit (enter) Bit[7:0]: Upper limit of unstable to stable range
0x3A10	AEC CONTROL 10	0x68	RW	Stable Range Low Limit (enter) Bit[7:0]: Lower limit of unstable to stable range
0x3A1B	AEC CONTROL 1B	0x78	RW	Stable Range High Limit (go out) Bit[7:0]: Upper limit of stable to unstable range
0x3A1E	AEC CONTROL 1E	0x68	RW	Stable Range Low Limit (go out) Bit[7:0]: Lower limit of stable to unstable range
0x3A11	AEC CONTROL 11	0xD0	RW	Step Manual Mode - fast zone high limit Bit[7:0]: Upper limit of fast AEC/AGC control zone
0x3A1F	AEC CONTROL 1F	0x40	RW	Step Manual Mode - fast zone low limit Bit[7:0]: Lower limit of fast AEC/AGC control zone

## 4.5 AEC/AGC steps

The AEC and AGC work together to obtain adequate exposure/gain based on the current environmental illumination. In order to achieve the best SNR, extending the exposure time is always preferred rather than raising the gain when the current illumination is getting brighter. Vice versa, under dark conditions, the action to decrease the gain is always taken prior to shortening the exposure time.

### 4.5.1 auto exposure control (AEC)

The function of the AEC is to calculate the integration time of the next frame and send the information to the timing control block. Based on the statistics of previous frames, the AEC is able to determine whether the integration time should increase, decrease, fast increase, fast decrease, or remain the same.

In extremely bright situations, the LAEC activates, allowing integration time to be less than one row. In extremely dark situations, the night mode activates, allowing integration time to be larger than one frame.

To avoid image flickering under a periodic light source, the integration time can be adjusted in steps of integer multiples of the period of the light source. This AEC step system is called the banding filter, suggesting that the exposure time is not continuous but falls in some steps.

#### 4.5.1.1 LAEC

If the integration time is only one row period but the image is too bright, AEC will enter LAEC mode. Within LAEC, the integration time can be further decreased to the minimal of 1/16 row. LAEC ON/OFF can be set in register bit **0x3A00[6]**.

#### 4.5.1.2 banding mode ON with AEC

In Banding ON mode, the exposure time will fall in steps of integer multiples of the period of light intensity. This design is to reject image flickering when the light source is not steady but periodical.

For a given light flickering frequency, the band step can be expressed in units of row period.

Band Step = 'period of light intensity' × 'frame rate' × 'rows per frame'.

The band steps for 50Hz and 60Hz light sources can be set in registers (**0x3A08[1:0]**, **0x3A09[7:0]**) and (**0x3A0A[1:0]**, **0x3A0B[7:0]**), respectively.

#### 4.5.1.3 banding mode OFF with AEC

When banding mode is OFF, integration time increases/decreases as normal. It is not necessarily multiples of band steps.

#### 4.5.1.4 night mode

The OV2710 supports long integration time such as 1 frame, 2 frames, 3 frames, 4 frames, 5 frames, 6 frames, 7 frames, and 8 frames in dark conditions. This is achieved by slowing down the original frame rate and waiting for exposure. Night mode ceiling can be set in register bits {**0x3A02[3:0]**, **0x3A03[7:0]**, **0x3A04[7:0]**} and {**0x3A14[3:0]**, **0x3A15[7:0]**, **0x3A16[7:0]**} for 60Hz and 50Hz, respectively. When banding is OFF, the ceiling is still set by these registers depending on register bits **0x3C01[7]** and **0x3C00[2]**. Night mode can be disabled by setting register bit **0x3A00[2]** to 0. Also, when in night mode, the increase and decrease step can be based on band or frames, depending on register **0x3A05[6]**. The minimal increase/decrease step can be one band. The step can be based both on bands and frames.

## 4.5.2 manual exposure control

To manually change exposure value, you must first set both 0x3503[0] and 0x3503[2], where 0x3503[0] enables manual exposure control and 0x3503[2] enables manual frame length - the number of lines in each frame or maximum exposure time, which is defined by registers 0x350C and 0x350D. In auto exposure mode, the maximum exposure values in registers 0x350C/0x350D automatically change. In manual exposure mode, these registers will not automatically change. The manually set exposure in registers 0x3500~0x3502 must be less than the maximum exposure value in 0x350C/0x350D. The exposure value in registers 0x3500~0x3502 is in units of line period/16, the low 4 bits (0x3502[3:0]) is the fraction of line in 1/16 steps, and the maximum value in 0x350C/0x350D is in units of lines. If the manually set exposure value is less than one pre-defined frame period (e.g., 1/15 second in 15fps), there is no need to change 0x350C/0x350D. If the exposure value needs to be set beyond the pre-defined frame period; in another words, if the frame period needs to be extended to extend exposure time, then the maximum frame value in 0x350C/0x350D needs to be set first, then the exposure can be set in registers 0x3500~0x3502 accordingly.

## 4.5.3 auto gain control (AGC)

Unlike prolonging integration time, increasing gain will amplify both signal and noise. Thus, AGC usually starts after AEC is full. However, in cases where adjacent AEC step changes are too large ( $>1/16$ ), AGC steps should be inserted in between; otherwise, the integration time will keep switching between two adjacent steps and the image flickers.

### 4.5.3.1 integration time between 1~16 rows

When integration time is less than 16 rows, the changes between adjacent AEC steps are larger than 1/16, which may possibly make the image oscillate between two AEC levels; thus, some AGC steps are added in between.

### 4.5.3.2 gain insertion between AEC banding steps

When banding mode is ON, the integration time changes in step of the period of light intensity. For the first 16 band steps, since the exposure time change between adjacent steps is larger than 1/16, AGC steps are inserted to ensure image stability.

### 4.5.3.3 gain insertion between night mode steps

Between night mode steps (e.g., integration time = 1 frame and 2 frames), AGC steps are inserted to ensure no adjacent step change is larger than 1/16.

### 4.5.3.4 when AEC reaches maximum

When AEC reaches its maximum step while the image is still too dark, the gain starts to increase until the new frame average falls into the stable range or AGC reaches its maximum step. The AGC ceiling can be set in {0x3A18[9:8], 0x3A19[7:0]}.

## 4.5.4 manual gain control

To manually change gain, first set register bit 0x3503[1] to enable manual control, then change the values in 0x350A/0x350B for the manual gain. The OV2710 has a maximum of 16x analog gain and 4x digital gain.

## 4.6 black level calibration (BLC)

The pixel array contains several optically shielded (black) lines. These lines are used as reference for black level calibration. There are two main functions of the BLC:

- adjusting all normal pixel values based on the values of the black levels
- applying multiplication to all pixel values based on digital gain

Black level adjustments can be made with registers 0x4000 through 0x401D shown in [table 4-6](#).

**table 4-6** BLC control functions

address	register name	default value	R/W	description
0x4000	BLC CTRL00	0x05	RW	Bit[7:1]: Not used Bit[0]: BLC enable 0: Disable 1: Enable
0x4006	BLACK LEVEL TARGET	0x00	RW	Black Level Target Bit[1:0]: l_blacklevel_target[9:8] Black level target
0x4007	BLACK LEVEL TARGET	0x20	RW	Black Level Target Bit[7:0]: l_blacklevel_target[7:0] Black level target
0x401D	BLC FRAME CONTROL	0x22	RW	Bit[1]: Format change enable 0: BLC does not change when format changes 1: Do n frames of BLC when image format changes Bit[0]: Not used

## 5 image sensor processor digital functions

### 5.1 system control

table 5-1 system control registers

address	register name	default value	R/W	description
0x3008	SYSTEM CONTROL00	0x02	RW	System Control Bit[7]: System software reset 0: Normal work mode 1: Software reset mode Bit[6]: System sleep mode 0: Normal work mode 1: Software sleep power down mode Bit[5:1]: Debug only Changing these values are not allowed Bit[0]: Not used
0x300F	PLL1 CTRL00	0x8A	RW	Bit[7:6]: Not used Bit[5:3]: Charge pump control Bit[2]: Not used Bit[1:0]: PLL SELD5 divider 0x: Bypass 10: Divided by 4 when in 8-bit mode 11: Divided by 5 when in 10-bit mode
0x3010	PLL1 CTRL01	0x00	RW	Bit[7:4]: PLL DIVS divider System divider ratio Bit[3:0]: PLL DIVM divider MIPI divider ratio
0x3011	PLL1 CTRL02	0x0A	RW	Bit[7]: PLL bypass Bit[5:0]: PLL DIVP
0x3012	PLL PREDIVIDER	0x00	RW	Bit[2:0]: PLL pre-divider ratio 000: 1 001: 1.5 010: 2 011: 2.5 100: 3 101: 4 110: 6 111: 8

OV2710

1080p/720p HD color CMOS image sensor with OmniPixel3-HS™ technology

Confidential for Zoran Digital Technologies (Shenzhen) Limited Only



## 6 image sensor output interface digital functions

### 6.1 digital video port (DVP)

#### 6.1.1 overview

The Digital Video Port (DVP) provides 10-bit parallel data output in all formats supported and extended features including compression mode, CCIR656 format, HSYNC mode and test pattern output.

**table 6-1** DVP control registers

address	register name	default value	R/W	description
0x4732	CCIR656 FS	0x01	RW	CCIR656 SYNC Code Frame start
0x4733	CCIR656 FE	0x0F	RW	CCIR656 SYNC Code Frame end
0x4734	CCIR656 LS	0x00	RW	CCIR656 SYNC Code Line start
0x4735	CCIR656 LE	0x00	RW	CCIR656 SYNC Code Line end
0x4740	POLARITY CTRL00	0x20	RW	DVP output polarity control Bit[5]: PCLK polarity 0: Active low 1: Active high Bit[4]: Reserved Bit[3]: Gate PCLK under VSYNC Bit[2]: Gate PCLK under HREF Bit[1]: HREF polarity 0: Active low 1: Active high Bit[0]: VSYNC polarity 0: Active low 1: Active high

### 6.2 mobile industry processor interface (MIPI)

MIPI provides a single uni-directional clock lane and two bi-directional data lane solution for communication links between components inside a mobile device. The two data lanes have full support for HS (uni-direction) and LP (bi-direction) data transfer mode. Contact your local OmniVision FAE for more details.

OV2710

1080p/720p HD color CMOS image sensor with OmniPixel3-HS™ technology

Confidential for Zoran Digital Technologies (Shenzhen) Limited Only

## 7 register tables

The following tables provide descriptions of the device control registers contained in the OV2710. For all registers enable/disable bits, ENABLE = 1 and DISABLE = 0. The device slave addresses are 0x6C for write and 0x6D for read.

**table 7-1** SC control registers (sheet 1 of 4)

address	register name	default value	R/W	description
0x3008	SYSTEM CONTROL00	0x02	RW	System Control Bit[7]: System software reset 0: Normal work mode 1: Software reset mode Bit[6]: System sleep mode 0: Normal work mode 1: Software sleep power down mode Bit[5:1]: Debug only Changing these values are not allowed Bit[0]: Not used
0x3009	NOT USED	–	–	Not Used
0x300A	PIDH	0x27	R	Product ID High Byte MSBs
0x300B	PIDL	0x10	R	Product ID Low Byte LSBs
0x300C~ 0x300D	NOT USED	–	–	Not Used
0x300E	MIPI CTRL00	0x00	RW	Bit[7:5]: Not used Bit[4]: MIPI high speed power down control 0: Enable MIPI PHY HS TX module 1: Power down MIPI PHY HS TX module Bit[3]: MIPI low power, power-down control 0: Enable MIPI PHY HS RX module 1: Power down MIPI PHY LP RX module Bit[2]: MIPI enable 0: DVP enable 1: MIPI enable Bit[1]: MIPI system suspend control 0: MIPI power ON 1: MIPI suspend Bit[0]: Not used

table 7-1 SC control registers (sheet 2 of 4)

address	register name	default value	R/W	description
0x300F	PLL CTRL00	0x8A	RW	Bit[7:6]: Not used Bit[5:3]: Charge pump control Bit[2]: Not used Bit[1:0]: PLL SELD5 divider 0x: Bypass 10: Divided by 4 when in 8-bit mode 11: Divided by 5 when in 10-bit mode
0x3010	PLL CTRL01	0x00	RW	Bit[7:4]: PLL DIVS divider System divider ratio Bit[3:0]: PLL DIVM divider MIPI divider ratio
0x3011	PLL CTRL02	0x0A	RW	Bit[7]: PLL bypass Bit[5:0]: PLL DIVP
0x3012	PLL PREDIVIDER	0x00	RW	Bit[7:3]: Not used Bit[2:0]: PLL1 pre-divider ratio 000: 1 001: 1.5 010: 2 011: 2.5 100: 3 101: 4 110: 6 111: 8
0x3013~ 0x3015	NOT USED	–	–	Not Used
0x3016	PAD OUTPUT ENABLE00	0x00	RW	Input/Output Control (0: input; 1: output) Bit[7:2]: Not used Bit[1]: Strobe OEN Bit[0]: SDA OEN
0x3017	PAD OUTPUT ENABLE01	0x00	RW	Input/Output Control (0: input; 1: output) Bit[7]: Not used Bit[6]: VSYNC OEN Bit[5]: HREF OEN Bit[4]: PCLK OEN Bit[3:0]: D[9:6] OEN
0x3018	PAD OUTPUT ENABLE02	0x00	RW	Input/Output Control (0: input; 1: output) Bit[7:2]: D[5:0] OEN Bit[1:0]: Not used
0x3019	PAD OUTPUT VALUE00	0x00	RW	GPIO Output Value Bit[7:2]: Not used Bit[1]: Strobe Bit[0]: SDA

table 7-1 SC control registers (sheet 3 of 4)

address	register name	default value	R/W	description
0x301A	PAD OUTPUT VALUE01	0x00	RW	GPIO Output Value Bit[7]: Not used Bit[6]: VSYNC Bit[5]: HREF Bit[4]: PCLK Bit[3:0]: D[9:6] output
0x301B	PAD OUTPUT VALUE02	0x00	RW	GPIO Output Value Bit[7:2]: D[5:0] output Bit[1:0]: Not used
0x301C	PAD OUTPUT SELECT00	0x00	RW	Output Selection for GPIO (0: normal data path; 1: register controlled GPIO) Bit[7:2]: Not used Bit[1]: Strobe select Bit[0]: SDA select
0x301D	PAD OUTPUT SELECT01	0x00	RW	Output Selection for GPIO (0: normal data path; 1: register controlled GPIO) Bit[7]: Not used Bit[6]: VSYNC select Bit[5]: HREF select Bit[4]: PCLK select Bit[3:0]: D[9:6] select
0x301E	PAD OUTPUT SELECT02	0x00	RW	Output Selection for GPIO (0: normal data path; 1: register controlled GPIO) Bit[7:2]: D[5:0] select Bit[1:0]: Not used
0x3025	CHIP REVISION	0x01	R	Chip Revision ID (for Rev 1C only)
0x302C	PAD OUTPUT DRIVE CAPABILITY	0x02	RW	Bit[7:6]: Output drive capability 00: 1x 01: 2x 10: 3x 11: 4x Bit[5:0]: Not used
0x3040	PAD INPUT VALUE00	–	R	Pad Input Status Bit[7:6]: Not used Bit[5]: TM Bit[4]: Not used Bit[3]: PWDN Bit[2]: PWUP Bit[1]: SCL Bit[0]: SDA

table 7-1 SC control registers (sheet 4 of 4)

address	register name	default value	R/W	description
0x3041	PAD INPUT VALUE01	–	R	Pad Input Status Bit[7]: OTP Bit[6]: VSYNC Bit[5]: HREF Bit[4]: PCLK Bit[3:0]: D[9:6] input
0x3042	PAD INPUT VALUE02	–	R	Pad Input Status Bit[7:2]: D[5:0] input Bit[1:0]: Not used

table 7-2 SCCB control registers

address	register name	default value	R/W	description
0x3100	SCCB ID	0x6C	RW	SCCB Slave ID
0x3103	PLL CLOCK SELECT	0x01	RW	PLL Clock Select Bit[7:2]: Not used Bit[1]: Select PLL input clock 0: From pad clock 1: From pre divider (clock modulator)
0x3104	SCCB PAD CLOCK DIVIDER	0x01	RW	Pad Clock Divider for SCCB Clock

table 7-3 group sharing registers (sheet 1 of 2)

address	register name	default value	R/W	description
0x3200	GROUP ADDR0	0x40	RW	Start Address for Group0 {group_addr0[7:0], 4'h0}
0x3201	GROUP ADDR1	0x4A	RW	Start Address for Group1 {group_addr1[7:0], 4'h0}
0x3202	GROUP ADDR2	0x54	RW	Start Address for Group2 {group_addr2[7:0], 4'h0}
0x3203	GROUP ADDR3	0x5E	RW	Start Address for Group3 {group_addr3[7:0], 4'h0}

table 7-3 group sharing registers (sheet 2 of 2)

address	register name	default value	R/W	description
0x3212	GROUP ACCESS	0x00	RW	Bit[7]: group_launch_en Bit[6]: Debug mode (must be 0) Bit[5]: group_launch Bit[4]: group_hold_end Bit[3:0]: group_id 00~11: ID of the group to hold register

table 7-4 analog registers

address	register name	default value	R/W	description
0x3621	ANA ARRAY 01	0x10	RW	Array Control Bit[7]: Horizontal binning Bit[6]: Horizontal skip
0x370D	SENSOR REG0D	0x0C	RW	Bit[7]: Debug mode Bit[6]: Vertical binning Bit[5:0]: Debug mode

table 7-5 timing control registers (sheet 1 of 2)

address	register name	default value	R/W	description
0x3800	TIMING CONTROL HS HIGHBYTE	0x01	RW	Bit[7:4]: Not used Bit[3:0]: HREF horizontal start point[11:8]
0x3801	TIMING CONTROL VH LOWBYTE	0x08	RW	Bit[7:0]: HREF horizontal start point[7:0]
0x3802	TIMING CONTROL VH HIGHBYTE	0x00	RW	Bit[7:4]: Not used Bit[3:0]: HREF vertical start point[11:8]
0x3803	TIMING CONTROL VH LOW BYTE	0x0A	RW	Bit[7:0]: HREF vertical start point[7:0]
0x3804	TIMING CONTROL HW HIGHBYTE	0x08	RW	Bit[7:4]: Not used Bit[3:0]: HREF horizontal width[11:8]
0x3805	TIMING CONTROL HW LOWBYTE	0x00	RW	Bit[7:0]: HREF horizontal width[7:0]
0x3806	TIMING CONTROL VH HIGHBYTE	0x06	RW	Bit[7:4]: Not used Bit[3:0]: HREF vertical height[11:8]
0x3807	TIMING CONTROL VH LOW BYTE	0x00	RW	Bit[7:0]: HREF vertical height[7:0]

table 7-5 timing control registers (sheet 2 of 2)

address	register name	default value	R/W	description
0x3808	TIMING CONTROL DVP HSIZE	0x08	RW	Bit[7:4]: Not used Bit[3:0]: DVP output horizontal width[11:8]
0x3809	TIMING CONTROL DVP HSIZE LOW	0x00	RW	Bit[7:0]: DVP output horizontal width[7:0]
0x380A	TIMING CONTROL DVP VSIZE HIGH	0x06	RW	Bit[7:4]: Not used Bit[3:0]: DVP output vertical height[11:8]
0x380B	TIMING CONTROL DVP VSIZE LOW	0x00	RW	Bit[7:0]: DVP output vertical height[7:0]
0x380C	TIMING CONTROL HTS HIGHBYTE	0x09	RW	Bit[7:4]: Not used Bit[3:0]: Total horizontal size[11:8]
0x380D	TIMING CONTROL HTS LOWBYTE	0x48	RW	Bit[7:0]: Total horizontal size[7:0]
0x380E	TIMING CONTROL VTS HIGHBYTE	0x06	RW	Bit[7:4]: Not used Bit[3:0]: Total vertical size[11:8]
0x380F	TIMING CONTROL VTS LOWBYTE	0x18	RW	Bit[7:0]: Total vertical size[7:0]
0x3810	TIMING CONTROL HV OFFSET	0xC2	RW	Bit[7:4]: Horizontal offset Bit[3:0]: Vertical offset
0x3814~ 0x3815	NOT USED	–	–	Not Used
0x3818	TIMING CONTROL18	0x80	RW	Bit[7]: Not used Bit[6]: Horizontal mirror Bit[5]: Vertical flip Bit[4:2]: Not used Bit[1]: Vertical subsample /4 Bit[0]: Vertical subsample /2

table 7-6 AEC/AGC registers (sheet 1 of 4)

address	register name	default value	R/W	description
0x3500	AEC PK EXPO	0x00	RW	Bit[7:4]: Not used Bit[3:0]: AEC exposure[19:16]
0x3501	AEC PK EXPO	0x00	RW	Bit[7:0]: AEC exposure[15:8]
0x3502	AEC PK EXPO	0x20	RW	Bit[7:0]: AEC exposure[7:0]



table 7-6 AEC/AGC registers (sheet 2 of 4)

address	register name	default value	R/W	description
0x3503	AEC PK MANUAL	0x00	RW	Bit[7:4]: Not used Bit[2]: VTS manual enable Bit[1]: AGC manual enable Bit[0]: AEC manual enable
0x3505~ 0x3509	NOT USED	–	–	Not Used
0x350A	AEC AGC ADJ	0x00	RW	Gain Output to Sensor Bit[7:1]: Not used Bit[0]: Gain high bit  Gain = (0x350A[0]+1) × (0x350B[7]+1) × (0x350B[6]+1) × (0x350B[5]+1) × (0x350B[4]+1) × (0x350B[3:0]/16+1)
0x350B	AEC AGC ADJ	0x00	RW	Gain Output to Sensor Bit[7:0]: Gain low bits  Gain = (0x350A[0]+1) × (0x350B[7]+1) × (0x350B[6]+1) × (0x350B[5]+1) × (0x350B[4]+1) × (0x350B[3:0]/16+1)
0x350C	AEC PK VTS	0x00	RW	Bit[7:0]: AEC VTS[15:8]
0x350D	AEC PK VTS	0x00	RW	Bit[7:0]: AEC VTS[7:0]
0x3A00	AEC CONTROL0	0x7C	RW	Bit[7]: Not used Bit[6]: Less 1 line enable 0: Less 1 line function disable 1: Less 1 line function enable Bit[5]: Band enable 0: Band function disable 1: Band function enable Bit[4]: Auto band enable 0: Exposure can not be less than 1 band 1: Exposure can be less than 1 band Bit[3]: Line complete 0: Fractional line enable 1: Fractional line disable Bit[2]: Night mode 0: Night mode disable 1: Night mode enable Bit[1]: Not used Bit[0]: Freeze 0: Freeze disable 1: Freeze enable

table 7-6 AEC/AGC registers (sheet 3 of 4)

address	register name	default value	R/W	description
0x3A01	AEC CONTROL1	0x04	RW	Bit[7:0]: Minimum exposure
0x3A02	AEC MAX EXPO 60	0x02	RW	Bit[7:4]: Not used Bit[3:0]: AEC maximum exposure for 60Hz[19:16]
0x3A03	AEC MAX EXPO 60	0x28	RW	Bit[7:0]: AEC maximum exposure for 60Hz[15:8]
0x3A04	AEC MAX EXPO 60	0x00	RW	Bit[7:0]: AEC maximum exposure for 60Hz[7:0]
0x3A05~ 0x3A07	NOT USED	–	–	Not Used
0x3A08	AEC B50 STEP	0x11	RW	Bit[7:6]: Not used Bit[5:0]: AEC band50 step[13:8]
0x3A09	AEC B50 STEP	0x40	RW	Bit[7:0]: AEC band50 step[7:0]
0x3A0A	AEC B60 STEP	0x11	RW	Bit[7:6]: Not used Bit[5:0]: AEC band60 step[13:8]
0x3A0B	AEC B60 STEP	0x40	RW	Bit[7:0]: AEC band60 step[7:0]
0x3A0C	NOT USED	–	–	Not Used
0x3A0D	AEC CONTROLD	0x04	RW	Bit[7:6]: Not used Bit[5:0]: Band60 max[5:0]
0x3A0E	AEC CONTROLE	0x03	RW	Bit[7:6]: Not used Bit[5:0]: Band50 max[5:0]
0x3A0F	AEC CONTROLF	0x78	RW	Bit[7:0]: Stable range high threshold 1
0x3A10	AEC CONTROL10	0x68	RW	Bit[7:0]: Stable range low threshold 1
0x3A11	AEC CONTROL11	0xD0	RW	Bit[7:0]: Fast zone high threshold
0x3A12	AEC CONTROL12	0x00	RW	Bit[7:0]: Manual average setting
0x3A13	AEC CONTROL13	0x50	RW	Bit[7:6]: Not used Bit[5]: Pre gain enable Bit[4:0]: Pre gain
0x3A14	AEC MAX EXPO50	0x02	RW	Bit[7:4]: Not used Bit[3:0]: AEC maximum exposure for 50Hz[19:16]
0x3A15	AEC MAX EXPO 50	0x28	RW	Bit[7:0]: AEC maximum exposure for 50Hz[15:8]
0x3A16	AEC MAX EXPO 50	0x00	RW	Bit[7:0]: AEC maximum exposure for 50Hz[7:0]

table 7-6 AEC/AGC registers (sheet 4 of 4)

address	register name	default value	R/W	description
0x3A17	AEC CONTROL17	0x89	RW	Bit[7:2]: Not used Bit[1:0]: Gain night threshold[1:0] 00: Night mode gain threshold as 1x 01: Night mode gain threshold as 2x 10: Night mode gain threshold as 4x 11: Not used
0x3A18	AEC G CEIL	0x03	RW	Bit[7:1]: Not used Bit[0]: AEC gain ceiling
0x3A19	AEC G CEIL	0xE0	RW	Bit[7:0]: AEC gain ceiling
0x3A1A	NOT USED	–	–	Not Used
0x3A1B	AEC CONTROL1B	0x78	RW	Bit[7:0]: Stable range high threshold 2
0x3A1C	AEC LED ADD ROW	0x06	RW	Bit[7:0]: Row adding number[15:8] in AEC LED mode
0x3A1D	AEC LED ADD ROW	0x18	RW	Bit[7:0]: Row adding number[7:0] in AEC LED mode
0x3A1E	AEC CONTROL1E	0x68	RW	Bit[7:0]: Stable range low threshold 2
0x3A1F	AEC CONTROL1F	0x40	RW	Bit[7:0]: Fast zone low threshold
0x3A20	AEC CONTROL20	0x20	RW	Bit[7:3]: Not used Bit[2]: Strobe option Bit[1]: Manual average enable 0: Average data manual set disable 1: Average data manual set enable Bit[0]: Not used
0x3A2E~ 0x3A30	NOT USED	–	–	Not Used

table 7-7 OTP registers (sheet 1 of 2)

address	register name	default value	R/W	description
0x3D00	OTP DATA 0	0x00	RW	OTP Dump/Load Data 0
0x3D01	OTP DATA 1	0x00	RW	OTP Dump/Load Data 1

table 7-7 OTP registers (sheet 2 of 2)

address	register name	default value	R/W	description
0x3D02	OTP DATA 2	0x00	RW	OTP Dump/Load Data 2
0x3D03	OTP DATA 3	0x00	RW	OTP Dump/Load Data 3
0x3D04	OTP DATA 4	0x00	RW	OTP Dump/Load Data 4
0x3D05	OTP DATA 5	0x00	RW	OTP Dump/Load Data 5
0x3D06	OTP DATA 6	0x00	RW	OTP Dump/Load Data 6
0x3D07	OTP DATA 7	0x00	RW	OTP Dump/Load Data 7
0x3D08	OTP DATA 8	0x00	RW	OTP Dump/Load Data 8
0x3D09	OTP DATA 9	0x00	RW	OTP Dump/Load Data 9
0x3D0A	OTP DATA A	0x00	RW	OTP Dump/Load Data A
0x3d0b	OTP DATA B	0x00	RW	OTP Dump/Load Data B
0x3d0c	OTP DATA C	0x00	RW	OTP Dump/Load Data C
0x3D0D	OTP DATA D	0x00	RW	OTP Dump/Load Data D
0x3D0E	OTP DATA E	0x00	RW	OTP Dump/Load Data E
0x3D0F	OTP DATA F	0x00	RW	OTP Dump/Load Data F
0x3D10	OTP CONTROL	0x00	RW	Bit[7:3]: Not used Bit[2]: OTP load option 0: Fast 1: Slow Bit[1:0]: OTP mode 00: OTP OFF 01: Load/dump OTP 10: Write/program OTP 11: OTP OFF

table 7-8 BLC registers

address	register name	default value	R/W	description
0x4000	BLC CONTROL 00	0x01	RW	Bit[7:4]: Not used Bit[3]: AVG frame enable 0: BLC is the calculating value 1: BLC will be the average of the calculating value and the original BLC Bit[2]: Not used Bit[1]: Freeze enable 0: BLC will be updated in some cases 1: BLC will be keep original value Bit[0]: BLC enable 0: Disable 1: Enable
0x4001	BLC CONTROL 01	0x00	RW	Bit[7:5]: Not used Bit[4:0]: Start line Start statistic black line Range from 0 to 31
0x4002	BLC CONTROL 02	0x00	RW	Bit[7]: Not used Bit[6]: Manual offset enable Bit[5:0]: Not used
0x4003~0x401C	NOT USED	—	—	Not Used
0x401D	BLC FRAME CONTROL	0x22	RW	Bit[7:6]: Not used Bit[5:4]: BLC enable mode 00: Always update 10: Update when gain changes x1: No update Bit[3:2]: Not used Bit[1]: Format change enable Bit[0]: Not used

table 7-9 FC control registers

address	register name	default value	R/W	description
0x4201	FRAME CTRL00	0x00	RW	Bit[7:4]: Not used Bit[3:0]: Frame ON number Control passed frame number When both ON and OFF numbers are set to 0x00, frame control is in bypass mode.
0x4202	FRAME CTRL01	0x00	RW	Bit[7:4]: Not used Bit[3:0]: Frame OFF number Control masked frame number When both ON and OFF numbers are set to 0x00, frame control is in bypass mode.

table 7-10 DVP registers (sheet 1 of 2)

address	register name	default value	R/W	description
0x4700	DVP CTRL00	0x04	RW	Bit[7:4]: Not used Bit[3]: CCIR656 v select Bit[2]: CCIR656 f value Bit[1]: CCIR656 mode enable Bit[0]: HSYNC mode enable
0x4701~ 0x4703	NOT USED	–	–	Not Used
0x4704	DVP CTRL01	0x00	RW	Bit[7:4]: Not used Bit[3:2]: Debug only Changing these values is not recommended Bit[1:0]: VSYNC mode enable 00: VSYNC1 mode enabled 01: VSYNC2 mode enabled 10: VSYNC3 mode enabled 11: Not used
0x4705~ 0x4707	NOT USED	–	–	Not Used
0x4708	DVP CTRL02	0x01	RW	Bit[7]: CLK DDR mode enable Bit[6]: Not used Bit[5]: VSYNC gate CLK enable Bit[4]: HREF gate CLK enable Bit[3]: Not used Bit[2]: HREF polarity Bit[1]: VSYNC polarity Bit[0]: PCLK gate low enable

table 7-10 DVP registers (sheet 2 of 2)

address	register name	default value	R/W	description
0x4709	DVP CTRL03	0x00	RW	Bit[7]: Video FIFO bypass mode Bit[6:4]: Data bit swap 000: Output data is the same order as input that is [9:0] 001: Output data is reversed, [0:9] 010: Output data is reordered as {[2:9], [1:0]} 011: Output data is reordered as {[7:0], [9:8]} 100: Output data is reordered as {[9:8], [0:7]} 101: Output data is reordered as {[9], [0:8]} 110: Output data is reordered as {[1:9], [0]} 111: Output data is reordered as {[8:0], [9]} Bit[3]: Test mode Bit[2]: Test mode 10-bit Bit[1]: Test mode 8-bit Bit[0]: Test mode enable

table 7-11 MIPI registers (sheet 1 of 5)

address	register name	default value	R/W	description
0x4800	MIPI CTRL 00	0x04	RW	Bit[7:6]: Not used Bit[5]: Clock lane gate enable 0: Enable 1: Disable Bit[4]: Line sync enable 0: Do not send line short packet for each line 1: Send line short packet for each line Bit[3]: Lane select 0: Use lane1 as default data lane 1: Use lane2 as default data lane Bit[2]: Idle status 0: MIPI bus will be LP00 when no packet is transmitted 1: MIPI bus will be LP11 when no packet is transmitted Bit[1:0]: Not used

table 7-11 MIPI registers (sheet 2 of 5)

address	register name	default value	R/W	description
				Bit[7]: Long packet data type manual enable 0: Use MIPI data type 1: Use manual data type Bit[6]: Short packet data type manual enable 0: Use auto value 1: Use manual value as short packet data Bit[5]: Short packet WORD COUNTER manual enable 0: Use frame counter or line counter 1: Select manual value Bit[4]: PH bit order for ECC 0: {DI[7:0],WC[7:0], WC[15:8]} 1: {DI[0:7],WC[0:7], WC[8:15]} Bit[3]: PH byte order for ECC 0: {DI,WC_l,WC_h} 1: {DI,WC_h,WC_l} Bit[2]: PH byte order2 for ECC 0: {DI,WC} 1: {WC,DI} Bit[1]: MARK1 enable for data lane1 0: Disable MARK1 1: When resume, lane1 should send MARK1 Bit[0]: MARK1 enable for data lane2 0: Disable MARK1 1: When resume, lane2 should send MARK1
0x4801	MIPI CTRL 01	0x04	RW	
0x4802	NOT USED	-	-	Not Used
				Bit[7:4]: Not used Bit[3]: Enable LP CD when HS TX for lane1 0: Disable 1: Enable Bit[2]: Enable LP CD when HS TX for lane2 0: Disable 1: Enable Bit[1]: Enable LP CD when LP TX for lane2 0: Disable 1: Enable Bit[0]: Enable LP CD when LP TX for lane1 0: Disable 1: Enable
0x4803	MIPI CTRL 03	0x5F	RW	



table 7-11 MIPI registers (sheet 3 of 5)

address	register name	default value	R/W	description
0x4804	MIPI CTRL 04	0x8C	RW	Bit[7:5]: Not used Bit[4]: Enable MIPI LP RX to read/write registers 0: Disable, RX LP data will write to VFIFO 1: Enable Bit[3]: Address read/write register will auto add 1 0: Disable 1: Enable Bit[2]: LP TX lane select 0: Select lane1 to transmit LP data 1: Select lane2 to transmit LP data Bit[1:0]: Not used
0x4805	MIPI CTRL 05	0x10	RW	Bit[7]: MIPI lane2 disable 0: Enable lane2 1: Disable MIPI data lane1, lane1 will be LP00 Bit[6]: MIPI lane1 disable 0: Enable lane1 1: Disable MIPI data lane1, lane1 will be LP00 Bit[5]: LPX Global timing select 0: Auto calculate T LPX in PCLK2X domain, unit CLK2X 1: Use lp_p_min[7:0] Bit[4:3]: Not used Bit[2]: MIPI read/write registers disable 0: Enable MIPI access SRB 1: Disable MIPI access SRB Bit[1:0]: Not used
0x4810	MAX FCNT H	0xFF	RW	High Byte of Max Frame Counter of Frame Sync Short Packet
0x4811	MAX FCNT L	0xFF	RW	Low Byte of Max Frame Counter of Frame Sync Short Packet
0x4812	MIN SPKT WC REG H	0x00	RW	High Byte of Manual Short Packet Word Counter
0x4813	MIN SPKT WC REG L	0x00	RW	Low Byte of Manual Short Packet Word Counter
0x4814	MIPI CTRL 14	0x2A	RW	Bit[7:6]: Virtual channel of MIPI packet Bit[5:0]: Data type manual
0x4815	MIPI SPKT DT	0x00	RW	Manual Data Type for Short Packet
0x4818	MIN HS ZERO H	0x00	RW	High Byte of Minimum Value of hs_zero, unit ns

table 7-11 MIPI registers (sheet 4 of 5)

address	register name	default value	R/W	description
0x4819	MIN HS ZERO L	0x96	RW	Low Byte of Minimum Value of hs_zero $hs\_zero\_real = hs\_zero\_min\_o + tui \times ui\_hs\_zero\_min\_o$
0x481A	MIN MIPI HS TRAIL H	0x00	RW	High Byte of Minimum Value of hs_trail, unit ns
0x481B	MIN MIPI HS TRAIL L	0x3C	RW	Low Byte of Minimum Value of hs_trail $hs\_trail\_real = hs\_trail\_min\_o + tui \times ui\_hs\_trail\_min\_o$
0x481C	MIN MIPI CLK ZERO H	0x01	RW	High Byte of Minimum Value of clk_zero, unit ns
0x481D	MIN MIPI CLK ZERO L	0x86	RW	Low Byte of Minimum Value of clk_zero $clk\_zero\_real = clk\_zero\_min\_o + tui \times ui\_clk\_zero\_min\_o$
0x481E	MIN MIPI CLK PREPARE H	0x00	RW	High Byte of Minimum Value of clk_prepare, unit ns
0x481F	MIN MIPI CLK PREPARE L	0x3C	RW	Low Byte of Minimum Value of clk_prepare $clk\_prepare\_real = clk\_prepare\_min\_o + tui \times ui\_clk\_prepare\_min\_o$
0x4820	MIN CLK POST H	0x00	RW	High Byte of Minimum Value of clk_post, unit ns
0x4821	MIN CLK POST L	0x56	RW	Low Byte of Minimum Value of clk_post $clk\_post\_real = clk\_post\_min\_o + tui \times ui\_clk\_post\_min\_o$
0x4822	MIN CLK TRAIL H	0x00	RW	High Byte of Minimum Value of clk_trail, unit ns
0x4823	MIN CLK TRAIL L	0x3C	RW	Low Byte of Minimum Value of clk_trail $clk\_trail\_real = clk\_trail\_min\_o + tui \times ui\_clk\_trail\_min\_o$
0x4824	MIN LPX PCLK H	0x00	RW	High Byte of Minimum Value of lpx_p, unit ns
0x4825	MIN LPX PCLK L	0x32	RW	Low Byte of Minimum Value of lpx_p $lpx\_p\_real = lpx\_p\_min\_o + tui \times ui\_lpx\_p\_min\_o$
0x4826	MIN HS PREPARE H	0x00	RW	High Byte of Minimum Value of hs_prepare, unit ns
0x4827	MIN HS PREPARE L	0x32	RW	Low Byte of Minimum Value of hs_prepare $hs\_prepare\_real = hs\_prepare\_min\_o + tui \times ui\_hs\_prepare\_min\_o$
0x4828	MIN HS EXIT H	0x00	RW	High Byte of Minimum Value of hs_exit, unit ns
0x4829	MIN HS EXIT L	0x64	RW	Low Byte of Minimum Value of hs_exit $hs\_exit\_real = hs\_exit\_min\_o + tui \times ui\_hs\_exit\_min\_o$
0x482A	MIN HS ZERO/UI	0x05	RW	Minimum UI Value of hs_zero, unit UI
0x482B	MIN HS TRAIL/UI	0x04	RW	Minimum UI Value of hs_trail, unit UI

table 7-11 MIPI registers (sheet 5 of 5)

address	register name	default value	R/W	description
0x482C	MIN CLK ZERO/UI	0x00	RW	Minimum UI Value of clk_zero, unit UI
0x482D	MIN CLK PREPARE/UI	0x00	RW	Minimum UI Value of clk_prepare, unit UI
0x482E	MIN CLK POST/UI	0x34	RW	Minimum UI Value of clk_post, unit UI
0x482F	MIN CLK TRAIL/UI	0x00	RW	Minimum UI Value of clk_trail, unit UI
0x4830	MIN LPX PCLK/UI	0x00	RW	Minimum UI Value of lpx_p (pclk2x domain), unit UI
0x4831	MIN HS PREPARE/UI	0x04	RW	Minimum UI Value of hs_prepare, unit UI
0x4832	MIN HS EXIT/UI	0x00	RW	Minimum UI Value of hs_exit, unit UI
0x4865	NOT USED	–	–	Not Used

table 7-12 ISP control registers (sheet 1 of 2)

address	register name	default value	R/W	description
0x5000	ISP CONTROL0	0xDF	RW	Bit[7]: LENC enable 0: Disable 1: Enable Bit[6:3]: Not used Bit[2]: Black pixel cancellation enable 0: Disable 1: Enable Bit[1]: White pixel cancellation enable 0: Disable 1: Enable Bit[0]: Not used
0x5001	ISP CONTROL1	0x4F	RW	Bit[7:1]: Not used Bit[0]: AWB enable 0: Disable 1: Enable
0x5002	ISP CONTROL2	0xE0	RW	Bit[73]: Not used Bit[2]: VAP enable 0: Disable 1: Enable Bit[1:0]: Not used
0x5003~ 0x5004	NOT USED	–	–	Not Used

table 7-12 ISP control registers (sheet 2 of 2)

address	register name	default value	R/W	description
0x5005	ISP CONTROL5	0xDC	RW	Bit[7:5]: Not used Bit[4]: AWB bias ON Bit[3:0]: Not used
0x5006~ 0x501E	NOT USED	–	–	Not Used
0x501F	ISP CONTROL31	0x03	RW	Bit[7:3]: Not used Bit[2:0]: Format select 000: Not used 001: Not used 010: Not used 011: ISP RAW 100: INT CIF RAW 101: Not used 111: Not used
0x5020~ 0x503C	NOT USED	–	–	Not Used
0x503D	ISP TEST	0x00	RW	Bit[7]: Color bar enable 0: Color bar OFF 1: Color bar enable Bit[6]: Not used Bit[5:4]: Color bar pattern select 10: Color bar pattern Bit[3]: Not used Bit[2]: Color bar rolling enable Bit[1:0]: Not used
0x503E	ISP SENSOR BIAS READOUT	–	R	ISP Sensor Bias Readout
0x503F	ISP SENSOR GAIN READOUT	–	R	ISP Sensor Gain Readout

table 7-13 AWB control registers (sheet 1 of 2)

address	register name	default value	R/W	description
0x3400	AWB GAIN PK RED GAIN	0x04	RW	Bit[7:4]: Not used Bit[3:0]: AWB R GAIN[11:8]
0x3401	AWB GAIN PK RED GAIN	0x00	RW	Bit[7:0]: AWB R GAIN[7:0]
0x3402	AWB GAIN PK GREEN GAIN	0x04	RW	Bit[7:4]: Not used Bit[3:0]: AWB G GAIN[11:8]
0x3403	AWB GAIN PK GREEN GAIN	0x00	RW	Bit[7:0]: AWB G GAIN[7:0]
0x3404	AWB GAIN PK BLUE GAIN	0x04	RW	Bit[7:4]: Not used Bit[3:0]: AWB B GAIN[11:8]
0x3405	AWB GAIN PK BLUE GAIN	0x00	RW	Bit[7:0]: AWB B GAIN[7:0]
0x3406	AWB GAIN PK AWB MAN CTRL	0x00	RW	Bit[7:1]: Not used Bit[0]: AWB manual control 0: AWB gain automatically updated 1: AWB gain manual enable
0x5180	AWB CONTROL 00	0x40	R/W	Bit[7]: Not used Bit[6]: fast_awb Bit[5]: freeze_gain_en Bit[4]: freeze_sum_en Bit[3]: Not used Bit[2]: start_sel Bit[1:0]: Not used
0x5181	AWB CONTROL 01	0x02	R/W	Bit[7:0]: Delta
0x5182	AWB CONTROL 02	0x04	RW	Bit[7:0]: Stable range
0x5183	STABLE RANGE WIDE	0x08	RW	Bit[7:0]: Stable range to determine whether it is in stable status when it is already in stable status
0x5184~0x518B	NOT USED	-	-	Not Used
0x518C	RED GAIN LIMIT	0xF0	RW	Bit[7:4]: Red gain up limit Maximum red gain is: red gain up limit *256 + 0xFF Bit[3:0]: Red gain down limit Minimum red gain is: red gain down limit *256 + 0

table 7-13 AWB control registers (sheet 2 of 2)

address	register name	default value	R/W	description
0x518D	GREEN GAIN LIMIT	0xF0	RW	Bit[7:4]: Green gain up limit Maximum green gain is: green gain up limit*256 + 0xFF Bit[3:0]: Green gain down limit Minimum green gain is: green gain down limit*256 + 0
0x518E	BLUE GAIN LIMIT	0xF0	RW	Bit[7:4]: Blue gain up limit Maximum blue gain is: blue gain up limit*256 + 0xFF Bit[3:0]: Blue gain down limit Minimum blue gain is: blue gain down limit*256 + 0
0x518F	AWB FRAME COUNTER	0x04	RW	Bit[7:4]: Not used Bit[3:0]: Number of frames to do AWB when AWB is in stable mode
0x5190~ 0x5195	NOT USED	–	–	Not Used
0x5196	RED BEFORE GAIN AVERAGE	–	R	Bit[7:0]: Before AWB gain's red data average
0x5197	GREEN BEFORE GAIN AVERAGE	–	R	Bit[7:0]: Before AWB gain's green data average
0x5198	BLUE BEFORE GAIN AVERAGE	–	R	Bit[7:0]: Before AWB gain's blue data average
0x5199	RED AFTER GAIN AVERAGE	–	R	Bit[7:0]: After AWB gain's red data average high byte
0x519A	RED AFTER GAIN AVERAGE	–	R	Bit[7:0]: After AWB gain's red data average low byte
0x519B	GREEN AFTER GAIN AVERAGE	–	R	Bit[7:0]: After AWB gain's green data average high byte
0x519C	GREEN AFTER GAIN AVERAGE	–	R	Bit[7:0]: After AWB gain's green data average low byte
0x519D	BLUE AFTER GAIN AVERAGE	–	R	Bit[7:0]: After AWB gain's blue data average high byte
0x519E	BLUE AFTER GAIN AVERAGE	–	R	Bit[7:0]: After AWB gain's blue average low byte
0x519F~ 0x51BD	NOT USED	–	–	Not Used

table 7-14 AVG registers

address	register name	default value	R/W	description
0x5680	AVG START POSITION AT HORIZONTAL	0x00	RW	Bit[7:4]: Not used Bit[3:0]: AVG start position[11:8] at horizontal
0x5681	AVG START POSITION AT HORIZONTAL	0x00	RW	Bit[7:0]: AVG start position[7:0] at horizontal
0x5682	AVG END POSITION AT HORIZONTAL	0x08	RW	Bit[7:4]: Not used Bit[3:0]: AVG end position[11:8] at horizontal
0x5683	AVG END POSITION AT HORIZONTAL	0x00	RW	Bit[7:0]: AVG end position[7:0] at horizontal
0x5684	AVG START POSITION AT VERTICAL	0x00	RW	Bit[7:3]: Not used Bit[2:0]: AVG start position[10:8] at vertical
0x5685	AVG START POSITION AT VERTICAL	0x80	RW	Bit[7:0]: AVG start position[7:0] at vertical
0x5686	AVG END POSITION AT VERTICAL	0x00	RW	Bit[7:3]: Not used Bit[2:0]: AVG end position[10:8] at vertical
0x5687	AVG END POSITION AT VERTICAL	0x38	RW	Bit[7:0]: AVG end position[7:0] at vertical
0x5688~ 0x568F	NOT USED	–	–	Not Used
0x5690	AVG R10	–	R	Bit[7:0]: Average of raw image[9:2]
0x5691	NOT USED	–	–	Not Used

table 7-15 DPC registers (sheet 1 of 2)

address	register name	default value	R/W	description
0x5780	DPC CTRL00	0x7F	RW	Bit[7]: Not used Bit[6]: Keep vertical channel 0: Do not keep vertical line 1: Keep vertical line Bit[5]: Enable same channel connected 0: Disable removing the same channel connected defected pixels 1: Enable removing the same channel connected defected pixels Bit[4]: Enable different channel connected 0: Disable removing the different channel connected defected pixels 1: Enable removing the different channel connected defected pixels Bit[3:2]: Matching index selection 00: No matching point check 01: Check the before and after pixels from the third to fourth pixels 10: Check the before and after pixels from the third to fifth pixels 11: Check the before and after pixels from the third to sixth pixels Bit[1:0]: Not used
0x5781	WHITE THRESHOLD LIST0	0x20	RW	Bit[7]: Not used Bit[6:0]: White pixel threshold list 0
0x5782	WHITE THRESHOLD LIST1	0x18	RW	Bit[7]: Not used Bit[6:0]: White pixel threshold list 1
0x5783	WHITE THRESHOLD LIST2	0x08	RW	Bit[7]: Not used Bit[6:0]: White pixel threshold list 2
0x5784	WHITE THRESHOLD LIST3	0x04	RW	Bit[7]: Not used Bit[6:0]: White pixel threshold list 3
0x5785	BLACK THRESHOLD LIST0	0x40	RW	Bit[7:0]: Black pixel threshold list 0
0x5786	BLACK THRESHOLD LIST1	0x18	RW	Bit[7:0]: Black pixel threshold list 1
0x5787	BLACK THRESHOLD LIST2	0x08	RW	Bit[7:0]: Black pixel threshold list 2



table 7-15 DPC registers (sheet 2 of 2)

address	register name	default value	R/W	description
0x5788	BLACK THRESHOLD LIST3	0x04	RW	Bit[7:0]: Black pixel threshold list 3
0x5789	GAIN LIST1	0x08	RW	Bit[7]: Not used Bit[6:0]: Gain list 1
0x578A	GAIN LIST2	0x20	RW	Bit[7]: Not used Bit[6:0]: Gain list 2
0x578B	DPC CTRL01	0x07	RW	Bit[7:4]: Not used Bit[3]: Mode 1 enable 0: Disable 1: Enable only remove cluster Bit[2]: Mode 2 enable 0: Disable 1: Enable Bit[1]: Not used Bit[0]: Enable mode 3 0: Disable 1: Enable
0x578C	DPC SATURATE	0x00	RW	Saturate Value Set for Cross Cluster
0x5790	PATTERN THRESHOLD LIST0	0x00	RW	Bit[7:2]: Not used Bit[1:0]: Pattern threshold list 0[9:8]
0x5791	PATTERN THRESHOLD LIST0	0x08	RW	Bit[7:0]: Pattern threshold list 0[7:0]
0x5792	PATTERN THRESHOLD LIST1	0x00	RW	Bit[7:2]: Not used Bit[1:0]: Pattern threshold list 1[9:8]
0x5793	PATTERN THRESHOLD LIST1	0x18	RW	Bit[7:0]: Pattern threshold list 1[7:0]
0x5794	PATTERN THRESHOLD LIST2	0x00	RW	Bit[7:2]: Not used Bit[1:0]: Pattern threshold list 2[9:8]
0x5795	PATTERN THRESHOLD LIST2	0x80	RW	Bit[7:0]: Pattern threshold list 2[7:0]
0x5796	PATTERN THRESHOLD LIST3	0x01	RW	Bit[7:2]: Not used Bit[1:0]: Pattern threshold list 3[9:8]
0x5797	PATTERN THRESHOLD LIST3	0x00	RW	Bit[7:0]: Pattern threshold list 3[7:0]

table 7-16 LENC registers (sheet 1 of 3)

address	register name	default value	R/W	description
0x5800	LENC RED X0	0x00	RW	Bit[7:0]: Red center horizontal position (x0) high bits
0x5801	LENC RED X0	0x0C	RW	Bit[7:0]: Red center horizontal position (x0) low eight bits
0x5802	LENC RED Y0	0x00	RW	Bit[7:0]: Red center vertical position (y0) high bits
0x5803	LENC RED Y0	0x06	RW	Bit[7:0]: Red center vertical position (y0) low eight bits
0x5804	LENC RED A1	0x22	RW	Bit[7:0]: Red parameter a1 a1 and a2 are used to generate the a parameter
0x5805	LENC RED A2	0x07	RW	Bit[7:0]: Red parameter a2 a1 and a2 are used to generate the parameter a
0x5806	LENC RED B1	0xC2	RW	Bit[7]: Sign bit 0: b1 is positive 1: b1 is negative Bit[6:0]: Red parameter b1 b1 and b2 are used to generate the parameter b
0x5807	LENC RED B2	0x08	RW	Bit[3:0]: Red parameter b2 b1 and b2 are used to generate the parameter b
0x5808	LENC GRN X0	0x00	RW	Bit[7:0]: Green center horizontal position (x0) high bits
0x5809	LENC GRN X0	0x0C	RW	Bit[7:0]: Green center horizontal position (x0) low eight bits
0x580A	LENC GRN Y0	0x00	RW	Bit[7:0]: Green center vertical position (y0) high bits
0x580B	LENC GRN Y0	0x06	RW	Bit[7:0]: Green center vertical position (y0) low eight bits
0x580C	LENC GRN A1	0x22	RW	Bit[7:0]: Green parameter a1 a1 and a2 are used to generate the parameter a
0x580D	LENC GRN A2	0x07	RW	Bit[7:0]: Green parameter a2 a1 and a2 are used to generate the parameter a

table 7-16 LENC registers (sheet 2 of 3)

address	register name	default value	R/W	description
0x580E	LENC GRN B1	0xC2	RW	Bit[7]: Sign bit 0: b1 is positive 1: b1 is negative Bit[6:0]: Green parameter b1 b1 and b2 are used to generate the parameter b
0x580F	LENC GRN B2	0x08	RW	Bit[3:0]: Green parameter b2 b1 and b2 are used to generate the parameter b
0x5810	LENC BLU X0	0x00	RW	Bit[7:0]: Blue center horizontal position (x0) high bits
0x5811	LENC BLU X0	0x0C	RW	Bit[7:0]: Blue center horizontal position (x0) low eight bits
0x5812	LENC BLU Y0	0x00	RW	Bit[7:0]: Blue center vertical position (y0) high bits
0x5813	LENC BLU Y0	0x06	RW	Bit[7:0]: Blue center vertical position (y0) low eight bits
0x5814	LENC BLU A1	0x22	RW	Bit[7:0]: Blue parameter a1 a1 and a2 are used to generate the parameter a
0x5815	LENC BLU A2	0x07	RW	Bit[7:0]: Blue parameter a2 a1 and a2 are used to generate the parameter a
0x5816	LENC BLU B1	0xC2	RW	Bit[7:0]: Sign bit 0: b1 is positive 1: b1 is negative Bit[6:0]: blue parameter b1 b1 and b2 are used to generate the parameter b
0x5817	LENC BLU B2	0x08	RW	Bit[7:4]: Not used Bit[3:0]: Blue parameter b2 b1 and b2 are used to generate the parameter b

table 7-16 LENC registers (sheet 3 of 3)

address	register name	default value	R/W	description
0x5818	LENC CTRL00	0x04	RW	Bit[7:3]: Not used Bit[2]: Round enable 0: Round disable, do not use random round bit 1: Round enable, generate random round bit Bit[1]: Coefficient manual enable 0: Disable coefficient manual mode 1: Enable coefficient manual mode, use auto mode to calculate the coefficient Bit[0]: gain coefficient enable 0: Use the gain = 128 to calculate the coefficient 1: Use the sensor gain to calculate the coefficient
0x5819	LENC COEF TH	0x80	RW	Bit[7:0]: LENC coefficient threshold
0x581A	LENC GAIN THRE1	0x00	RW	Bit[7:0]: LENC gain low threshold (t1)
0x581B	LENC GAIN THRE2	0x00	RW	Bit[7:0]: LENC gain high threshold (t2)
0x581C	LENC COEF MAN	0x80	RW	Bit[7:0]: Coefficient manual input

table 7-17 AFC registers

address	register name	default value	R/W	description
0x6000	AFC CTRL00	0x1F	RW	Bit[7:5]: Not used Bit[4]: Edge filter enable 0: afc_edge module will not update 1: afc_edge module will update Bit[3]: Edge filter b select 0: DGE selects b2 1: Edge selects b1 Bit[2:0]: Edge filter a select 000: Edge selects a1 001: Edge selects a2 010: Edge selects a3 100: Edge selects a4 101: Edge selects a5
0x6001	AFC CTRL01	0x01	RW	Bit[7:0]: Edge window0 left coordinate
0x6002	AFC CTRL02	0x00	RW	Bit[7:0]: Edge window0 top coordinate
0x6003	AFC CTRL03	0x76	RW	Bit[7:0]: Edge window0 right coordinate
0x6004	AFC CTRL04	0x42	RW	Bit[7:0]: Edge window0 bottom coordinate This bottom must be larger than any other
0x6005	AFC CTRL05	0x01	RW	Bit[7:0]: Edge window1 left coordinate
0x6006	AFC CTRL06	0x00	RW	Bit[7:0]: Edge window1 top coordinate
0x6007	AFC CTRL07	0x76	RW	Bit[7:0]: Edge window1 right coordinate
0x6008	AFC CTRL08	0x42	RW	Bit[7:0]: Edge window1 bottom coordinate
0x6009	AFC CTRL09	0x01	RW	Bit[7:0]: Edge window2 left coordinate
0x600A	AFC CTRL10	0x00	RW	Bit[7:0]: Edge window2 top coordinate
0x600B	AFC CTRL11	0x76	RW	Bit[7:0]: Edge window2 right coordinate
0x600C	AFC CTRL12	0x42	RW	Bit[7:0]: Edge window2 bottom coordinate
0x600D	AFC CTRL13	0x01	RW	Bit[7:0]: Edge window3 left coordinate
0x600E	AFC CTRL14	0x00	RW	Bit[7:0]: Edge window3 top coordinate
0x600F	AFC CTRL15	0x76	RW	Bit[7:0]: Edge window3 right coordinate
0x6010	AFC CTRL16	0x42	RW	Bit[7:0]: Edge window3 bottom coordinate
0x6011	AFC CTRL17	0x01	RW	Bit[7:0]: Edge window4 left coordinate
0x6012	AFC CTRL18	0x00	RW	Bit[7:0]: Edge window4 top coordinate
0x6013	AFC CTRL19	0x76	RW	Bit[7:0]: Edge window4 right coordinate
0x6014	AFC CTRL20	0x42	RW	Bit[7:0]: Edge window4 bottom coordinate
0x6015~ 0x603C	NOT USED	–	–	Not Used

OV2710

1080p/720p HD color CMOS image sensor with OmniPixel3-HS™ technology

Confidential for Zoran Digital Technologies (Shenzhen) Limited Only

## 8 operating specifications

### 8.1 absolute maximum ratings

**table 8-1** absolute maximum ratings

parameter		absolute maximum rating <sup>a</sup>
ambient storage temperature		-40°C to +125°C
supply voltage (with respect to ground)	V <sub>DD-A</sub>	4.5V
	V <sub>DD-D</sub>	3V
	V <sub>DD-IO</sub>	4.5V
electro-static discharge (ESD)	human body model	2000V
	machine model	200V
all input/output voltages (with respect to ground)		-0.3V to V <sub>DD-IO</sub> + 1V
I/O current on any input or output pin		±200 mA
peak solder temperature (10 second dwell time)		260°C

- a. exceeding the absolute maximum ratings shown above invalidates all AC and DC electrical specifications and may result in permanent damage to the device. Exposure to absolute maximum rated conditions for extended periods may affect device reliability.

### 8.2 functional temperature

**table 8-2** functional temperature

parameter	range
operating temperature range <sup>a</sup>	-30°C to +70°C
stable image temperature range <sup>b</sup>	0°C to +50°C

- a. sensor functions but image quality may be noticeably different at temperatures outside of stable image range  
 b. image quality remains stable throughout this temperature range

### 8.3 DC characteristics

**table 8-3** DC characteristics ( $-30^{\circ}\text{C} < T_A < 70^{\circ}\text{C}$ )

symbol	parameter	min	typ	max	unit
supply					
$V_{DD-A}$	supply voltage (analog)	3.0	3.3	3.6	V
$V_{DD-D}^a$	supply voltage (digital core)	1.425	1.5	1.575	V
$V_{DD-IO}$	supply voltage (digital I/O)	1.7	1.8	3.6	V
$I_{DD-A}$	active (operating) current		80	90	mA
$I_{DD-IO}^{b, c}$			48	60	mA
$I_{DDS-SCCB}$	standby current		0.6	1	mA
$I_{DDS-PWDN}$			70	120	$\mu\text{A}$
digital inputs (typical conditions: $AV_{DD} = 3.3\text{V}$ , $DV_{DD} = 1.5\text{V}$ , $DOV_{DD} = 1.8\text{V}$ )					
$V_{IL}$	input voltage LOW			0.54	V
$V_{IH}$	input voltage HIGH	1.26			V
$C_{IN}$	input capacitor			10	pF
digital outputs (standard loading 25 pF)					
$V_{OH}$	output voltage HIGH	1.62			V
$V_{OL}$	output voltage LOW			0.18	V
serial interface inputs <sup>d</sup>					
$V_{IL}$	SIOC and SIOD	-0.5	0	0.54	V
$V_{IH}$	SIOC and SIOD	1.26	1.8	2.3	V

a. using the internal DVDD regulator is strongly recommended for minimum power down current

b. active current is based on sensor resolution at full size and at full speed

c. with MIPI function, the active current needs an additional 20mA

d. based on  $DOV_{DD} = 1.8\text{V}$ .



## 8.4 AC characteristics

**table 8-4** AC characteristics ( $T_A = 25^\circ\text{C}$ ,  $V_{DD-A} = 2.8\text{V}$ )

symbol	parameter	min	typ	max	unit
ADC parameters					
B	analog bandwidth		40		MHz
DLE	DC differential linearity error		0.5		LSB
ILE	DC integral linearity error		1		LSB
	settling time for hardware reset			<1	ms
	settling time for software reset			<1	ms
	settling time for resolution mode change			<1	ms
	settling time for register setting			<300	ms

**table 8-5** timing characteristics

symbol	parameter	min	typ	max	unit
oscillator and clock input					
$f_{\text{osc}}$	frequency (XVCLK)	6	24	27	MHz
$t_r$ , $t_f$	clock input rise/fall time			5 (10 <sup>a</sup> )	ns

a. if using internal PLL

OV2710

1080p/720p HD color CMOS image sensor with OmniPixel3-HS™ technology

Confidential for Zoran Digital Technologies (Shenzhen) Limited Only

## 9 mechanical specifications

### 9.1 physical specifications

figure 9-1 package specifications

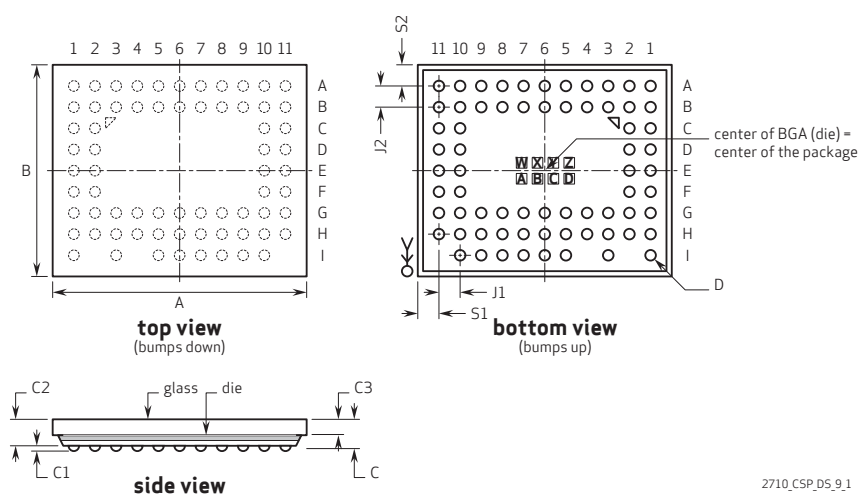
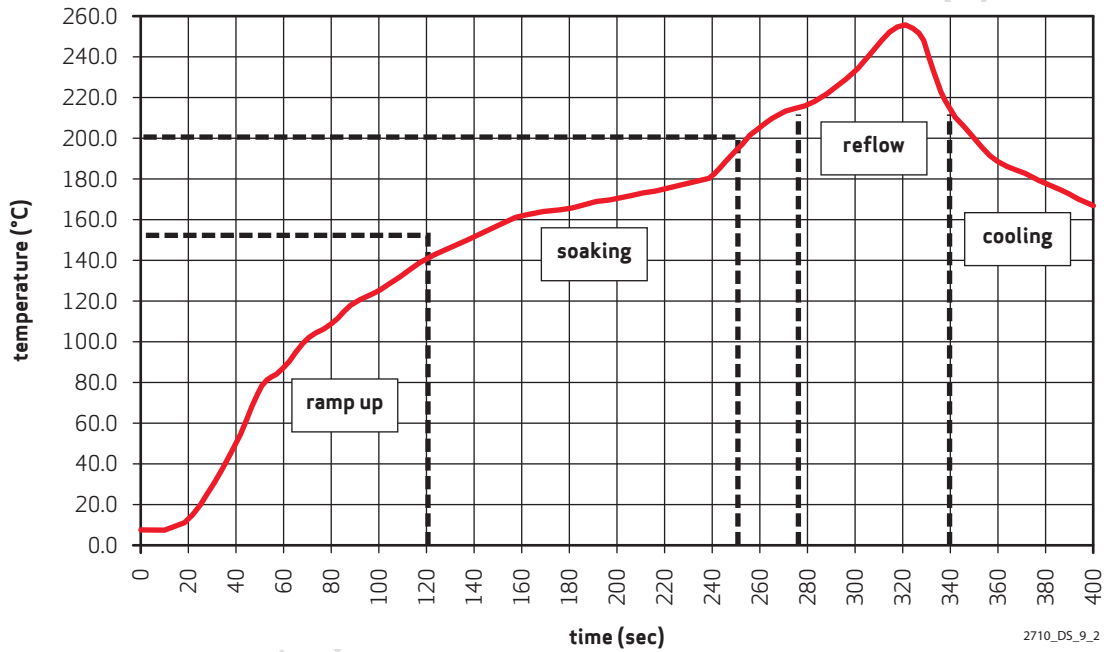

table 9-1 package dimensions

parameter	symbol	min	typ	max	unit
package body dimension x	A	7440	7465	7490	$\mu\text{m}$
package body dimension y	B	5840	5865	5890	$\mu\text{m}$
package height	C	720	780	840	$\mu\text{m}$
ball height	C1	130	160	190	$\mu\text{m}$
package body thickness	C2	575	620	665	$\mu\text{m}$
cover glass thickness	C3	425	445	465	$\mu\text{m}$
ball diameter	D	270	300	330	$\mu\text{m}$
total pin count	N		68 (23 NC)		
pin count x-axis	N1		11		
pin count y-axis	N2		9		
pins pitch x-axis	J1		640		$\mu\text{m}$
pins pitch y-axis	J2		600		$\mu\text{m}$
edge-to-pin center distance analog x	S1	503	533	563	$\mu\text{m}$
edge-to-pin center distance analog y	S2	503	533	563	$\mu\text{m}$

## 9.2 IR reflow specifications

figure 9-2 IR reflow ramp rate requirements



**note**

The OV2710 uses a lead-free package.

table 9-2 reflow conditions<sup>a</sup>

zone	description	exposure
ramp up	heating from room temperature to 150°C	temperature slope ≤ 3°C per second
soaking	heating from 150°C to 200°C	90 ~ 150 seconds
reflow	temperature higher than 217°C	30 ~ 120 seconds
peak	maximum temperature in SMT	260°C
cooling	cooling from 217°C to room temperature	temperature slope ≤ 6°C per second

a. maximum number of reflow cycles = 3

## 10 optical specifications

### 10.1 sensor array center

figure 10-1 sensor array center

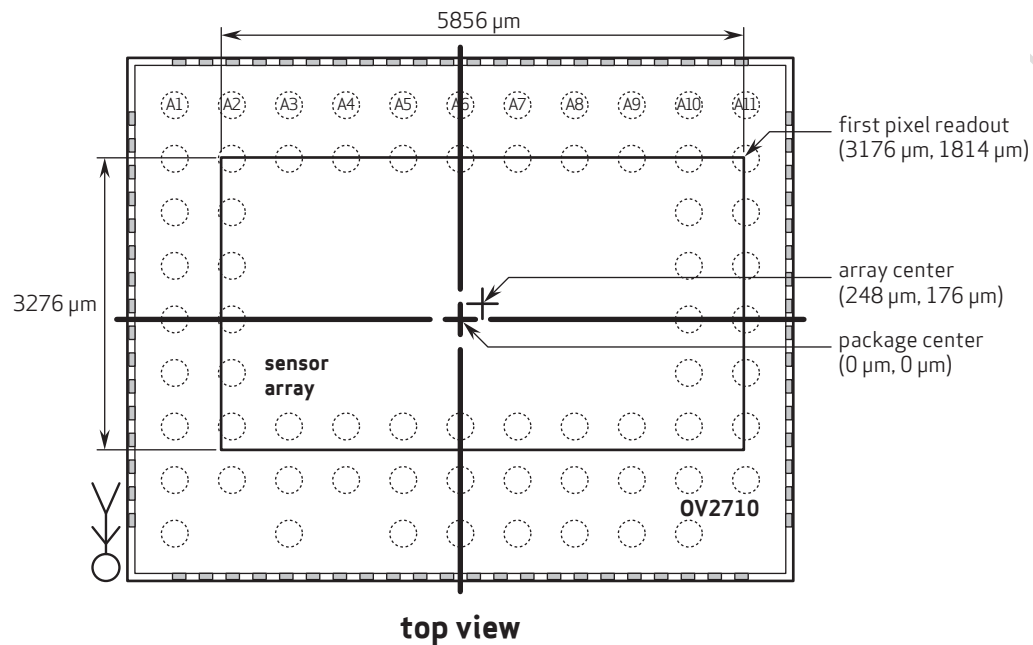

**note 1** this drawing is not to scale and is for reference only.

**note 2** as most optical assemblies invert and mirror the image, the chip is typically mounted with pins A1 to A11 oriented down on the PCB.

2710\_ S \_DS\_10\_1

## 10.2 lens chief ray angle (CRA)

figure 10-2 chief ray angle (CRA)

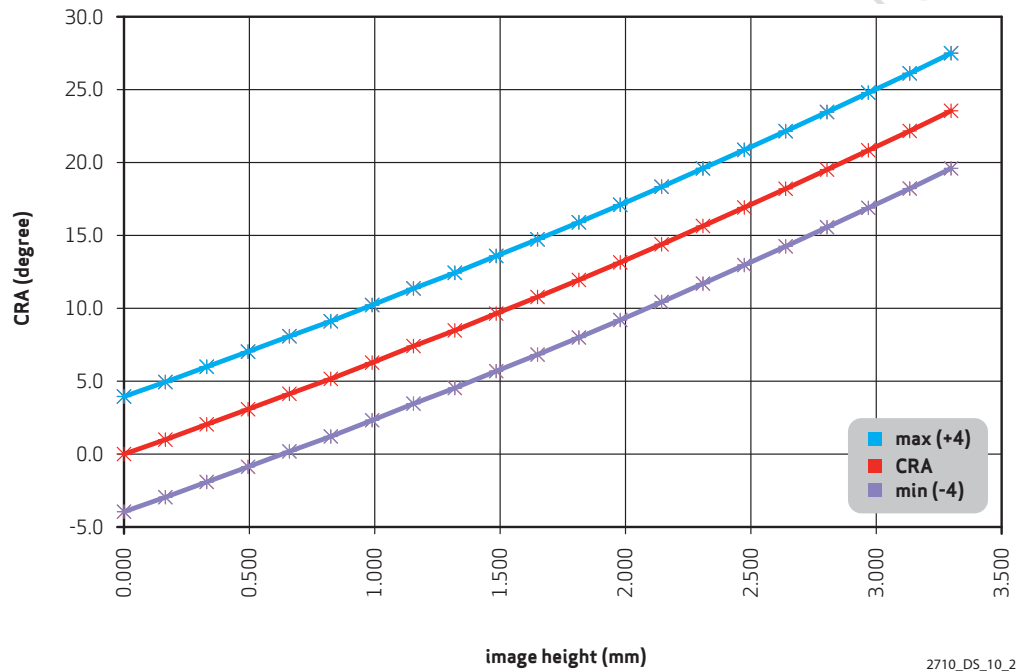

table 10-1 CRA versus image height plot (sheet 1 of 2)

field (%)	image height (mm)	CRA (degrees)	maximum +4 degree	minimum +4 degree
0	0.000	0.0	4.0	-4.0
0.05	0.165	1.0	5.0	-3.0
0.1	0.330	2.1	6.1	-1.9
0.15	0.496	3.1	7.1	-0.9
0.2	0.661	4.2	8.2	0.2
0.25	0.826	5.2	9.2	1.2
0.3	0.991	6.3	10.3	2.3
0.35	1.156	7.4	11.4	3.4
0.4	1.322	8.5	12.5	4.5

**table 10-1** CRA versus image height plot (sheet 2 of 2)

field (%)	image height (mm)	CRA (degrees)	maximum +4 degree	minimum +4 degree
0.45	1.487	9.7	13.7	5.7
0.5	1.652	10.8	14.8	6.8
0.55	1.817	12.0	16.0	8.0
0.6	1.982	13.2	17.2	9.2
0.65	2.148	14.4	18.4	10.4
0.7	2.313	15.7	19.7	11.7
0.75	2.478	16.9	20.9	12.9
0.8	2.643	18.2	22.2	14.2
0.85	2.808	19.5	23.5	15.5
0.9	2.974	20.9	24.9	16.9
0.95	3.139	22.2	26.2	18.2
1	3.304	23.6	27.6	19.6

**OV2710**

1080p/720p HD color CMOS image sensor with OmniPixel3-HS™ technology

Confidential for Zoran Digital Technologies (Shenzhen) Limited Only



## revision history

### version 1.0 05.20.2009

- initial release

### version 1.1 11.19.2009

- in title on cover page, in key specifications section on page iii, and in chapter 2 on page 2-1, changed optical format from 1/3" to 1/2.7"
- in key specifications on page iii, added power requirements for active and power down
- in key specifications on page iii, changed sensitivity from TBD to 3300 mV/(Lux-sec)
- in key specifications on page iii, changed S/N ratio from TBD to 39 dB
- in key specifications on page iii, changed dynamic range from TBD to 69 dB
- in key specifications on page iii, changed maximum exposure interval from TBD to 1096 tline
- in key specifications on page iii, changed dark current from TBD to 10 mV/sec @ 60°C
- in key specifications on page iii, changed well capacity from TBD to 13 Ke<sup>-</sup>
- in key specifications on page iii, changed fixed pattern noise (FPN) from TBD to 1% of  $V_{PEAK-TO-PEAK}$
- in table 1-1, added footnote a to pin B7 (TM)
- in table 2-1, added 80 MHz to pixel clock column of QVGA row
- after table 2-4, changed sentence "After that, setting both group\_launch and group\_launch\_en to 1 will write the buffered values to the real registers" to "After that, both group\_launch and group\_launch\_en should be set to 1 in order to write the buffered values to the real registers"
- in section 2.8, deleted first paragraph and replaced it with "Based on the system power configuration, the power up sequence will differ."
- corrected figure 3-1
- in subsection 4.5.1.4, changed third sentence to "Night mode ceiling can be set in register bits {0x3A02[3:0], 0x3A03[7:0], ..."
- in section 4.5.2, changed sentence "The exposure value in registers 0x3500–0x3502 is in units of line\*16 - the low 4 bits (0x3502[3:0]) is the fraction of line, the maximum value in 0x350C/0x350D is in unit of line." to "The exposure value in registers 0x3500–0x3502 is in units of line period/16, the low 4 bits (0x3502[3:0]) is the fraction of line in 1/16 steps, and the maximum value in 0x350C/0x350D is in units of lines. "
- in table 5-1, changed descriptions of register bits 0x3008[5:0]
- in table 7-1, changed descriptions of register bits 0x3008[5:0]
- in table 7-1 on page 7-3, added description of register 0x3025
- deleted table 7-4 and moved all rows to table 7-3, group sharing registers
- deleted table 7-5 and moved all rows to (number adjusted) table 7-13, AWB control registers
- deleted table 7-6 and moved all rows to (number adjusted) table 7-6, AEC/AGC registers
- deleted table 7-8 and moved all rows to (number adjusted) table 7-4, analog registers
- in (number adjusted) table 7-10, changed descriptions of register bits 0x4704[3:0]

- in table 8-3, changed TBDs for IDD-A to 80 typ and 90 max
- in table 8-3, changed TBDs for IDD-IO to 48 typ and 60 max
- in table 8-3, changed TBDs for IDDS-SCCB to 0.6 typ and 1 max
- in table 8-3, changed TBDs for IDDS-PWDN to 70 typ and 120 max
- in table 8-4, changed TBDs for analog bandwidth to 40 typ
- in table 8-4, changed TBDs for DC differential linearity error to 0.5 typ
- in table 8-4, changed TBDs for DC integral linearity error to 1 typ
- in table 8-4, changed TBDs for settling time for hardware reset to <1 max
- in table 8-4, changed TBDs for settling time for software reset to <1 max
- in table 8-4, changed TBDs for settling time for resolution mode time change to <1 max
- in table 8-4, changed TBDs for settling time for register setting to <300 max

Confidential for Zoran Digital Technologies (Shenzhen) Limited Only



the clear advantage™

## OmniVision Technologies, Inc.

### UNITED STATES

4275 Burton Drive  
Santa Clara, CA 95054

tel: +1 408 567 3000

fax: +1 408 567 3001

email: [salesamerican@ovt.com](mailto:salesamerican@ovt.com)

### UNITED KINGDOM

Hampshire +44 1256 744 610

### FINLAND

Mouhijärvi +358 3 341 1898

### GERMANY

Munich +49 89 63 81 99 88

### CHINA

Beijing +86 10 6580 1690

Shanghai +86 21 6105 5100

Shenzhen +86 755 8384 9733

Hong Kong +852 2403 4011

### JAPAN

Tokyo +81 3 5765 6321

### KOREA

Seoul +82 2 3478 2812

### SINGAPORE +65 6562 8250

### TAIWAN

Taipei +886 2 2657 9800 -  
ext.#100